



NANYANG PRIMARY SCHOOL

**MID-YEAR PRACTICE  
2023**

**PRIMARY 6**

**MATHEMATICS  
PAPER 1  
(BOOKLET A)**

Total Duration for Booklets A and B: 1 hour

Additional materials: Optical Answer Sheet (OAS)

**INSTRUCTIONS TO PUPILS**

1. Do not turn over this page until you are told to do so.
2. Follow all instructions carefully.
3. Answer all questions.
4. Shade your answers in the Optical Answer Sheet (OAS) provided.
5. The use of calculators is **NOT** allowed.

Name: \_\_\_\_\_ (      )

Class: Primary 6 (      )

Questions 1 to 10 carry 1 mark each. Questions 11 to 15 carry 2 marks each.  
For each question, four options are given. One of them is the correct answer.  
Make your choice (1, 2, 3 or 4) and shade your answer on the Optical Answer  
Sheet. (20 marks)

---

1 In the number line below, what is the value of X?

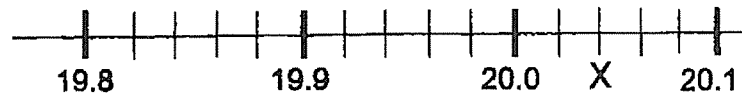

- (1) 20.4
- (2) 20.2
- (3) 20.04
- (4) 20.02

2 Find the value of  $\frac{5}{6} \div \frac{1}{4}$ .

- (1)  $\frac{10}{3}$
- (2)  $\frac{5}{24}$
- (3)  $\frac{3}{10}$
- (4)  $\frac{24}{5}$

- 3 Joyce baked some cookies. She gave 80% of the cookies to Zac. Zac ate 20% of the cookies he received from Joyce. Which one of the following shows the percentage of total cookies that Zac ate?

(1)  $\frac{1}{5} \times 20\%$

$20\% \times 80\%$

(2)  $\frac{1}{5} \times 80\%$

(3)  $\frac{4}{5} \times 80\%$

(4)  $\frac{4}{5} \times 100\%$

- 4 The square grid below shows Triangle P. What type of triangle is Triangle P?

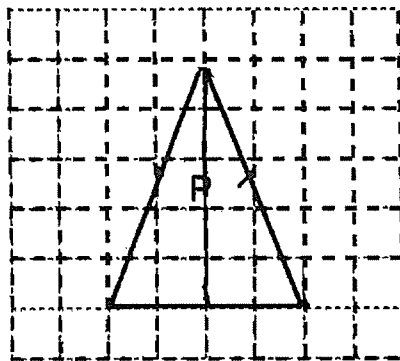

- (1) Obtuse-angled triangle  
(2) Right-angled triangle  
(3) Equilateral triangle  
(4) Isosceles triangle

- 5 In the figure below, WXYZ is a rhombus.

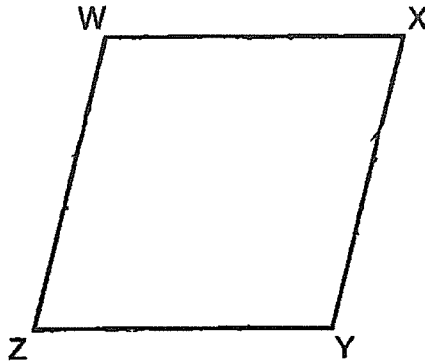

Which one of the following is false?

- (1)  $WX \parallel ZY$
- (2)  $\angle WZY + \angle XYZ = 180^\circ$
- (3)  $\angle XYZ = \angle XWZ$
- (4)  $\angle WZY = \angle ZWX$

- 6 ABC is a triangle with  $AB = 10$  cm and  $BC = 15$  cm.  $BE = 8$  cm and  $AD = 21$  cm. Find the area of triangle ABC.

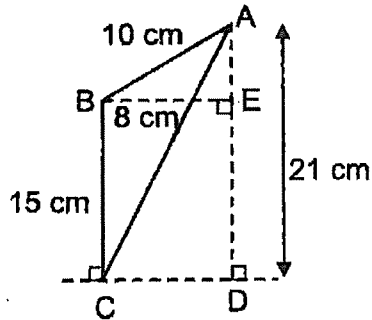

- (1)  $40 \text{ cm}^2$   
(2)  $60 \text{ cm}^2$   
(3)  $75 \text{ cm}^2$   
(4)  $84 \text{ cm}^2$
- 7 What is the area of a circle with diameter 60 cm?  
( Take  $\pi = 3.14$  )
- (1)  $94.2 \text{ cm}^2$   
(2)  $188.4 \text{ cm}^2$   
(3)  $2826 \text{ cm}^2$   
(4)  $11\,304 \text{ cm}^2$

- 8 Which of the following is likely to be the length of an approved scientific calculator for PSLE?

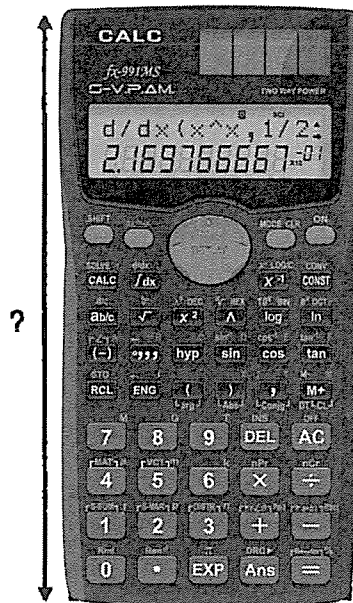

- (1) 0.018 m
- (2) 0.18 m
- (3) 1.8 m
- (4) 18 m

Use the information below to answer questions 9 and 10.

The bar graph below shows the number of cars sold from June to September.

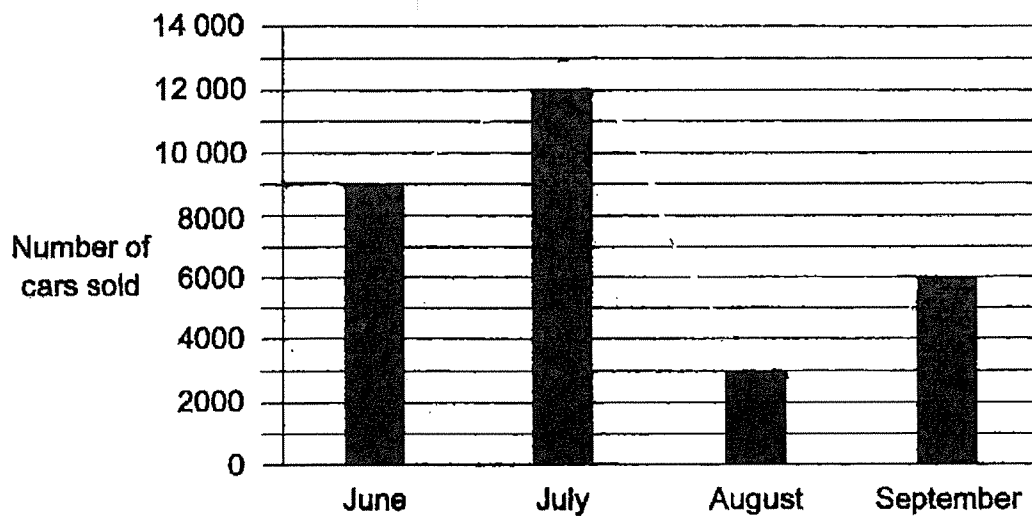

9 In which month was the number of cars sold half as many as the number of cars sold in September?

- (1) June
- (2) July
- (3) August
- (4) September

**10** Which one of the following statements is true?

- (1) The number of cars sold in June was 8500.
- (2) The number of cars sold in July is  $\frac{3}{4}$  the number of cars sold in June.
- (3) The increase in the number of cars sold from August to September was 9000.
- (4) The total number of cars sold in June and August is the same as the number of cars sold in July.

**11** Last month, a florist sold 800 roses. This month, she sold 1000 roses. What was the percentage increase in the number of roses sold?

- (1) 20%
- (2) 25%
- (3) 80%
- (4) 200%



- 12 The figure below is made up of 3 identical quarter circles of radius 28 cm. Find its perimeter. ( Take  $\pi = \frac{22}{7}$  )

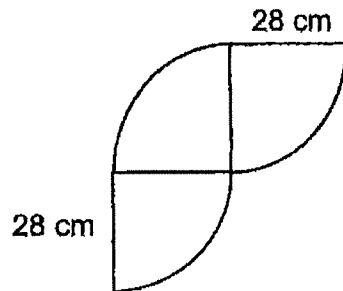

- (1) 132 cm  
(2) 176 cm  
(3) 188 cm  
(4) 232 cm
- 13 A lollipop cost \$0.70. There were 80 lollipops in a box. Janie bought 8 such boxes of lollipops for her class party. How much did she spend on the lollipops?
- (1) \$408  
(2) \$428  
(3) \$448  
(4) \$560

- 14 At first, a rectangular tank measuring 40 cm by 30 cm by 30 cm contained some water as shown below.

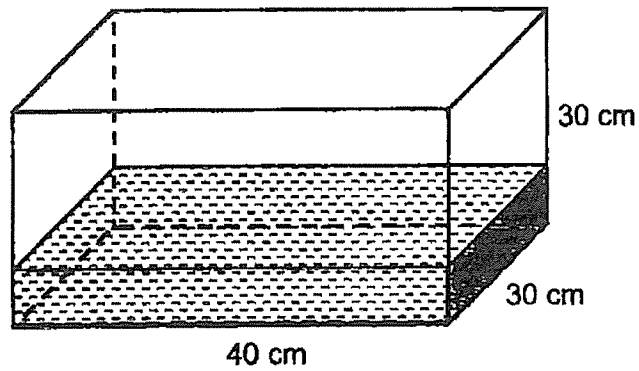

After Melvin poured 2400 ml of water into the tank, the tank became  $\frac{2}{3}$ -filled with water. How much water was there in the tank at first?

- (1) 21 600 cm<sup>3</sup>
- (2) 24 000 cm<sup>3</sup>
- (3) 26 400 cm<sup>3</sup>
- (4) 36 000 cm<sup>3</sup>

- 15 Ranjeet and Samy made some birthday cards over two days. On Saturday, Ranjeet made 29 more cards than Samy. On Sunday, Ranjeet made another 30 cards and Samy made another 25 cards. At the end of the two days, Ranjeet made  $\frac{3}{5}$  of the total number of cards. What was the total number of cards Samy made over the two days?

- (1) 34
- (2) 68
- (3) 102
- (4) 170



NANYANG PRIMARY SCHOOL

MID-YEAR PRACTICE  
2023

PRIMARY 6

MATHEMATICS  
PAPER 1  
(BOOKLET B)

Total Duration for Booklets A and B: 1 hour

**INSTRUCTIONS TO PUPILS**

1. Do not turn over this page until you are told to do so.
2. Follow all instructions carefully.
3. Answer all questions.
4. Write your answers in this booklet.
5. The use of calculators is **NOT** allowed.

Name: \_\_\_\_\_ (      )

Class: Primary 6 (      )

Booklet B

/ 25

Questions 16 to 20 carry 1 mark each. Write your answers in the spaces provided. For questions which require units, give your answers in the units stated. (5 marks)

---

16 Express  $3\frac{1}{4}$  as a decimal.

Ans: \_\_\_\_\_

---

17 The volume of a cube is  $125 \text{ cm}^3$ . Find the length of one edge of the cube.

Ans: \_\_\_\_\_ cm

---

- 18 John stacked 7 unit cubes and glued them together to form the solid below.

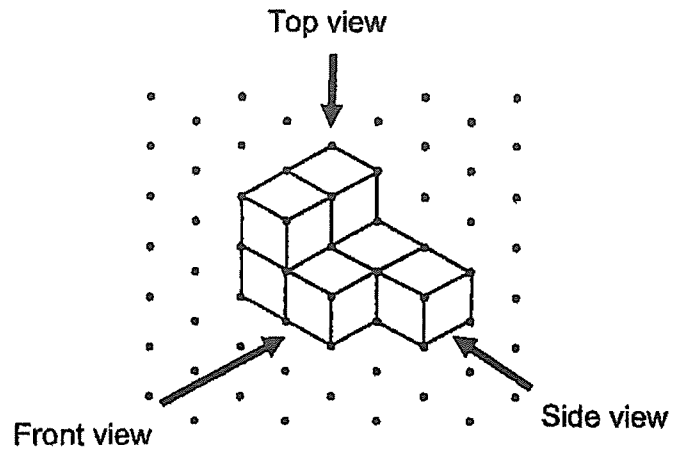

Draw the top view of the solid on the grid below.

Top View

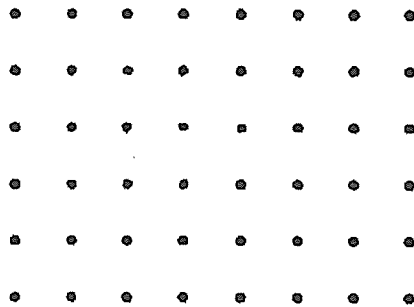

- 19 In the figure below, ABC is an isosceles triangle.  $AB = AC$ .  $\angle BAC = 36^\circ$ . Find  $\angle ABC$ .

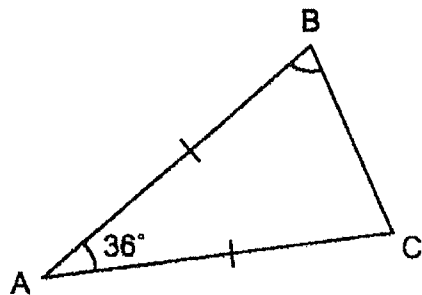

Ans: \_\_\_\_\_<sup>o</sup>

---

- 20 In the figure below, WXYZ is a trapezium and WX is parallel to ZY.  $\angle WXY = 56^\circ$  and  $\angle WZY = 66^\circ$ . Find  $\angle XWZ$ .

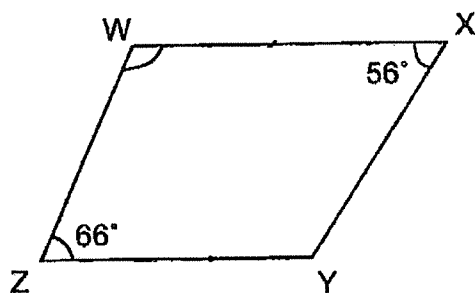

Ans: \_\_\_\_\_<sup>o</sup>

---

Questions 21 to 30 carry 2 marks each. Show your working clearly and write your answers in the spaces provided. For questions which require units, give your answers in the units stated. (20 marks)

- 21 In the figure below, RSVW is a square and WTUV is a parallelogram. WST is a straight line.  $\angle TVS = 7^\circ$ . Find  $\angle TVU$ .

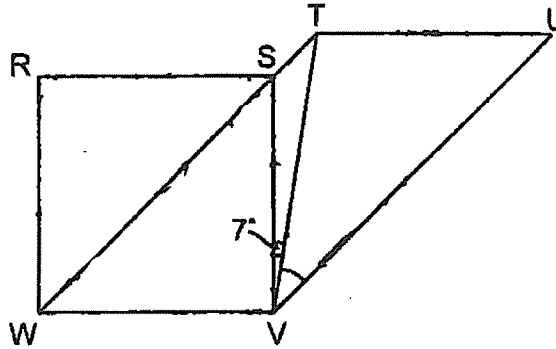

Ans: \_\_\_\_\_ °

- 22 Find the circumference of a circle of diameter 28 m. (Take  $\pi = \frac{22}{7}$ )

Ans: \_\_\_\_\_ m



- 23 The figure below shows a square and a quarter circle. The length of the square is 20 cm. Find the area of the shaded part. Leave your answer in terms of  $\pi$ .

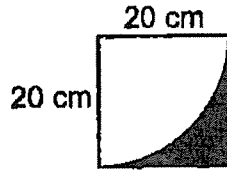

Ans: \_\_\_\_\_  $\text{cm}^2$

- 24 A straight line EF is drawn on a square grid inside a box.

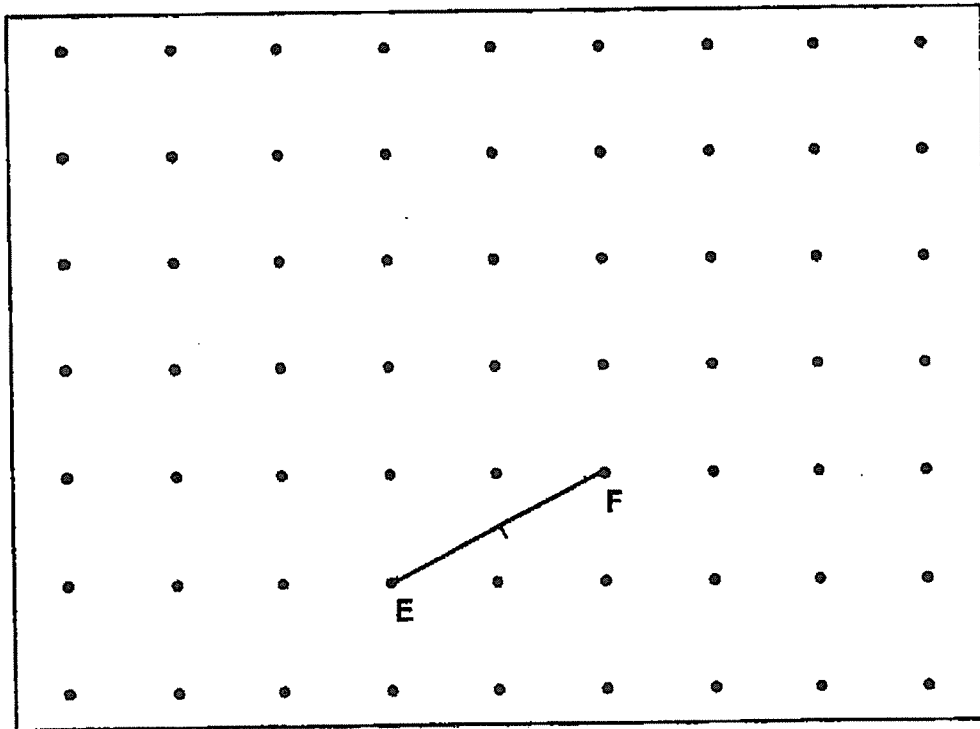

G is one of the dots inside the box. Draw two lines FG and EG to complete triangle EFG with  $\angle EFG = 90^\circ$  and  $EF = FG$ .

- 25 A cuboid is 0.4 m long and 20 cm wide. It has a volume of 20 000 cm<sup>3</sup>. Find the height of the cuboid.

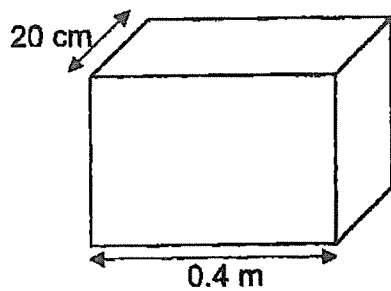

Ans: \_\_\_\_\_ cm

---

- 26 Two numbers add up to 364. One of the numbers is a 2-digit number and the other is a 3-digit number. What is the smallest possible difference between the two numbers?

Ans: \_\_\_\_\_

---

**27** Use all the digits 7, 0, 4 and 5 to form

(a) the smallest multiple of 10

Ans: (a) \_\_\_\_\_

(b) the even number closest to 5000

Ans: (b) \_\_\_\_\_

---

- 28 Shanice had a bottle of shampoo. She used an equal amount of shampoo each day. At the end of the 7<sup>th</sup> day,  $\frac{4}{5}$  of the bottle was left. At the end of the 15<sup>th</sup> day, the amount of shampoo left was 280 ml. What was the amount of shampoo in the bottle at first?

Ans: \_\_\_\_\_ ml

---

- 29 A rectangular block P was cut along the dotted line into two smaller rectangular blocks Q and R as shown below. The volume of Q was  $\frac{2}{3}$  the volume of R. The difference in volume between Q and R was  $12\,000\text{ cm}^3$ . Find the unknown edge of block P.

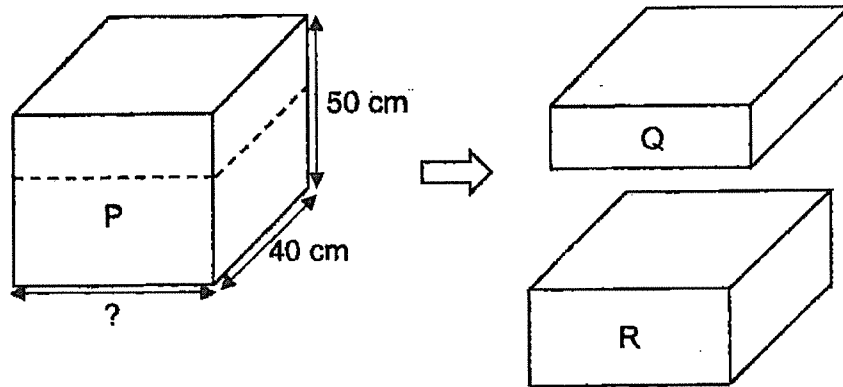

Ans: \_\_\_\_\_ cm

- 30 Devi collected  $\frac{5}{12}$  as many foreign coins as Haminah. Haminah collected  $\frac{6}{7}$  as many foreign coins as Liling. What was the ratio of the number of foreign coins Devi collected to the number of foreign coins Liling collected?

Ans: \_\_\_\_\_

---

End of Paper



NANYANG PRIMARY SCHOOL

**MID-YEAR PRACTICE  
2023**

**PRIMARY 6**

**MATHEMATICS  
PAPER 2**

Duration: 1 hour 30 minutes

**INSTRUCTIONS TO PUPILS**

1. Do not turn over this page until you are told to do so.
2. Follow all instructions carefully.
3. Answer all questions.
4. Write your answers in this booklet.
5. The use of an approved calculator is allowed.

Name: \_\_\_\_\_ (      )

Class: Primary 6 (      )

<b>Booklet A</b>	<b>/ 20</b>
<b>Booklet B</b>	<b>/ 25</b>
<b>Paper 2</b>	<b>/ 55</b>
<b>Total</b>	<b>/ 100</b>

Questions 1 to 5 carry 2 marks each. Show your working clearly and write your answers in the spaces provided. For questions which require units, give your answers in the units stated. (10 marks)

---

- 1 The table below shows the number of storybooks read by each student in a class. Part of the table is covered by an ink blot. There were 20 students who read less than 3 storybooks. There were twice as many students who read 3 storybooks as those who read 5 storybooks.

Number of storybooks	1	2	3	4	5
Number of students	9			3	4

- (a) How many students read 2 storybooks?

Ans: (a) \_\_\_\_\_

- (b) How many students were there in the class?

Ans: (b) \_\_\_\_\_

---

- 2 A wheel of diameter 40 cm made 10 complete turns. Find the distance covered. (Take  $\pi = 3.14$ )

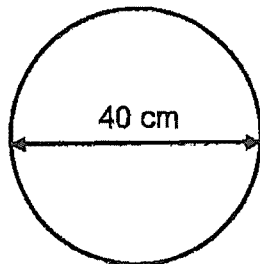

Ans: \_\_\_\_\_ cm

---



- 3 The price of a pair of shoes was \$80 before discount. Richard bought the pair of shoes at a discount of 15% during a sale. How much did he pay for the pair of shoes?

Ans: \$ \_\_\_\_\_

---

- 4 A machine prints 390 posters in 13 minutes. At this rate, how long does it take to print 2250 posters?

Ans: \_\_\_\_\_ min

---

- 5 The average of 6 consecutive whole numbers is 35.5. Find the smallest number.

Ans: \_\_\_\_\_

---

For questions 6 to 17, show your working clearly and write your answers in the spaces provided. The number of marks available is shown in brackets [ ] at the end of each question or part-question. (45 marks)

---

- 6 There are 12 fewer workers in factory A than factory B.  $\frac{1}{8}$  of the workers in factory A are male. There are 36 more female workers than male workers in factory A. How many workers are there in factory B?

Ans: \_\_\_\_\_ [3]

---

- 7 The figure below is made up of a right-angled triangle, a rectangle and 2 semicircles. Find the total area of the shaded parts. (Take  $\pi = 3.14$ )

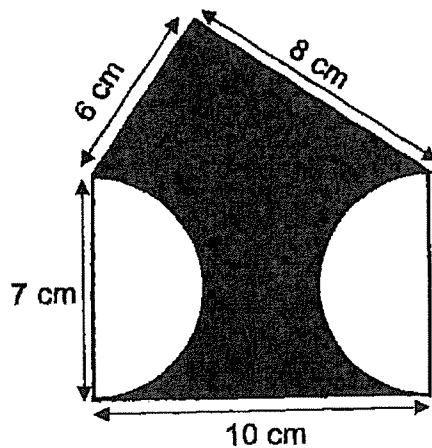

Ans: \_\_\_\_\_ [3]

- 8 Joe had a rectangular piece of paper, 36.8 cm by 29 cm, as shown below. He cut out as many squares as possible from the paper. The side of each square was 5 cm. At most, how many squares did Joe cut out?

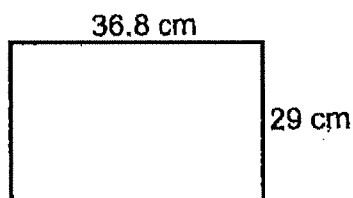

Ans: \_\_\_\_\_ [3]

- 9 Pedro had a 700-cm long rope. He cut it into 3 pieces, A, B and C. The length of rope A was divisible by 3 and 7. The length of rope B was 4 times the length of rope A. The total length of rope A and rope B was less than 450 cm. The length of rope C was longer than the length of rope A but shorter than the length of rope B.

(a) What was the length of rope C?

Ans: (a) \_\_\_\_\_ [2]

(b) What was the total length of rope A and rope B?

Ans: (b) \_\_\_\_\_ [1]

---

- 10 In the figure below, JKLM is a rhombus. MNK is a straight line and  $MN = ML$ .  $\angle MNL$  is  $24^\circ$  more than  $\angle LMN$ . Find  $\angle MJK$ .

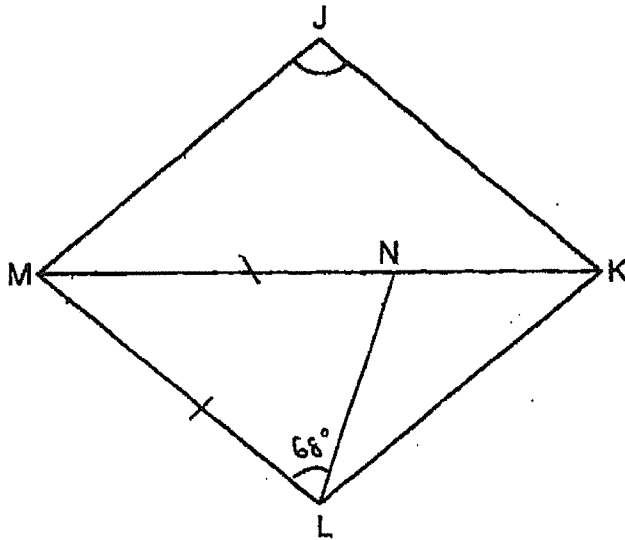

Ans: \_\_\_\_\_ [3]

- 11 In the figure below, BCDE is a trapezium. BC is parallel to ED. BEH is an equilateral triangle and EFGH is a square.

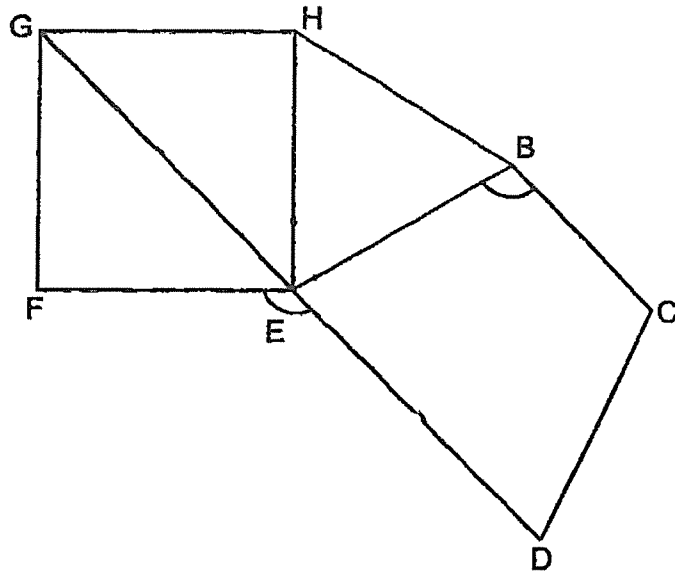

- (a) Find  $\angle DEF$ .

Ans: (a) \_\_\_\_\_ [2]

- (b) Find  $\angle EBC$ .

Ans: (b) \_\_\_\_\_ [2]

**12** Mrs Menon baked some cookies. 60% of the cookies were almond cookies and the rest were chocolate cookies. She then sold half of her almond cookies and had 78 almond cookies left.

- (a) Did the percentage of the cookies that were chocolate increase, decrease or remain the same after the sale of the almond cookies? Show your working clearly.

Ans: (a) \_\_\_\_\_ [1]

- (b) How many cookies did Mrs Menon bake?

Ans: (b) \_\_\_\_\_ [3]

---

- 13 A rectangular tank with a base area of  $3500 \text{ cm}^2$  and a height of  $80 \text{ cm}$  was  $\frac{1}{4}$ -filled with water at first. At 8 a.m., a tap was turned on and water was drained from the tank at the rate of 4 litres per minute. At 8.06 a.m., the tap was turned off.

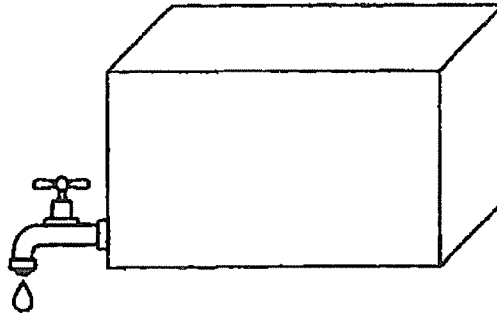

- (a) How much water was drained from the tank?

Ans: (a) \_\_\_\_\_ [1]

- (b) After the tap was turned off, how much more water was needed to fill the tank completely?

Ans: (b) \_\_\_\_\_ [3]



14 A pencil and an eraser cost \$1.05. The pencil and a ruler cost \$0.85. Bernice paid \$6.90 for 8 such pencils and 5 such erasers. Chandra paid \$3.30 for some rulers.

(a) What was the cost of one such eraser?

Ans: (a) \_\_\_\_\_ [2]

(b) How many such rulers did Chandra buy?

Ans: (b) \_\_\_\_\_ [2]

---

- 15 Karl had clips of four different colours.  $\frac{1}{8}$  of the clips were white and  $\frac{2}{7}$  of the remaining clips were red. He had an equal number of blue clips and yellow clips. Karl had 35 blue clips.

(a) How many red clips did he have?

Ans: (a) \_\_\_\_\_ [2]

- (b) Karl packed all the blue clips into small, medium, and large boxes. He filled each small box with 2 clips, each medium box with 3 clips and each large box with 6 clips. All the boxes were full and there was no clips left over. What was the least number of boxes used by Karl?

Ans: (b) \_\_\_\_\_ [2]

---

- 16 The figure is drawn on a rectangular piece of paper 30 cm by 40 cm as shown below. Its outline consists of 4 identical quarter circles and 5 straight lines. (Take  $\pi = 3.14$ )

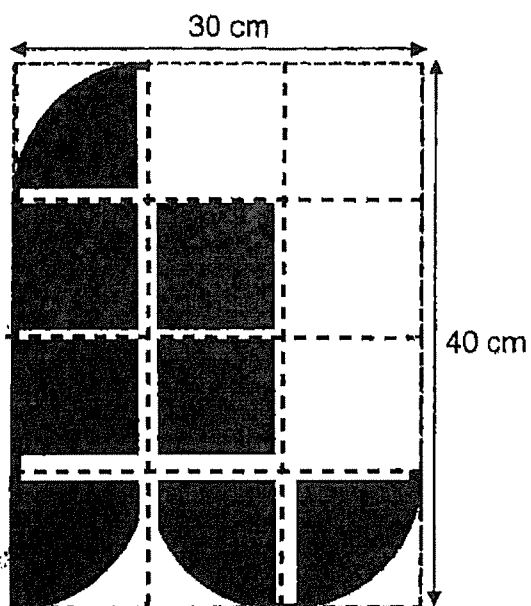

- (a) Find the perimeter of the figure.

Ans: (a) \_\_\_\_\_ [2]

- (b) Find the area of the shaded figure.

Ans: (b) \_\_\_\_\_ [3]

- 17 Two pouches, Y and Z, contained some gold tokens and silver tokens at first. In Pouch Y, the ratio of the number of gold tokens to the number of silver tokens was 3 : 1. In Pouch Z, the ratio of the number of gold tokens to the number of silver tokens was 1 : 4. Pouch Z had 5 times as many tokens as Pouch Y.

- (a) What was the ratio of the number of gold tokens in Pouch Y to the number of silver tokens in Pouch Z?

Ans: (a) \_\_\_\_\_ [1]

- (b) After 24 gold tokens and 24 silver tokens were transferred from Pouch Z to Pouch Y, the ratio of the number of gold tokens to the number of silver tokens in Pouch Y became 9 : 5. What was the total number of tokens in Pouch Y in the end?

Ans: (b) \_\_\_\_\_ [2]

- (c) What was the total number of tokens in both pouches, Y and Z, at first?

Ans: (c) \_\_\_\_\_ [2]

---

End of Paper

YEAR : 2023  
 LEVEL : PRIMARY 6  
 SCHOOL : NANYANG PRIMARY SCHOOL  
 SUBJECT : MATHEMATICS  
 TERM. : MID-YEAR PRACTICE

**(BOOKLET A)**

Q1	3	Q2	1	Q3	2	Q4	4	Q5	4
Q6	2	Q7	3	Q8	2	Q9	3	Q10	4
Q11	2	Q12	3	Q13	3	Q14	1	Q15	2

**(BOOKLET B)**

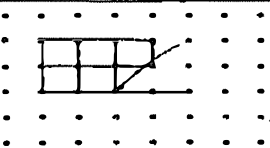
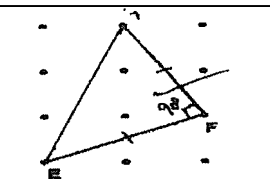
Q16	3.25	Q17	$\sqrt[3]{125} = 5\text{cm}$
Q18		Q19	$180 - 36 = 144$ $144 \div 2 = 72^\circ$
Q20	$180 - 66 = 114^\circ$	Q21	$180 - 90 = 90$ $90 \div 2 = 45$ $45 + 97 = 142$ $180 - 142 = 38^\circ$
Q22	$28\text{m} \div 2 = 14$ $2 \times \frac{22}{7} \times 14 = 88\text{m}$	Q23	$\frac{1}{4} \times \pi \times 20^2 = 100\pi \text{cm}^2$ $20\text{cm} \times 20\text{cm} = 400\text{cm}^2$ $(400 - 100\pi) \text{cm}^2$
Q24		Q25	$20\text{cm} \times 0.4\text{m} = 800\text{cm}^2$ $20\,000\text{cm}^3 \div 800\text{cm}^2 = 25\text{cm}$
Q26	Highest possible 2 digit no. is 99 $364 - 99 = 265$ $265 - 99 = 166$	Q27	a) 4570 b) 5074
Q28	Every 7 days $\rightarrow \frac{5}{5} - \frac{4}{5} = \frac{1}{5}$ 1 day $\rightarrow \frac{1}{5} \div 7 = \frac{1}{35}$ By day 15 : $\frac{1}{35} \times 15 = \frac{15}{35}$ $\frac{35}{35} - \frac{15}{35} = \frac{20}{35}$ $\frac{20}{35} = 280\text{ml}$ $\frac{1}{35} \rightarrow 14\text{ml}$ $\frac{35}{35} \rightarrow 14\text{ml} \times 35$ 490ml	Q29	2 units + 3 units = 5 units 30cm = 5 units 1 unit = 10cm 3 - 2 = 1 $\dot{1} \rightarrow 12\,000\text{cm}^3$ $12\,000\text{cm}^3 \div 40 \div 10 = 30\text{cm}$

Q30	D : H : L 5 : 12 6 : 7 5 : 12 : 7 Ans: 5 : 14
-----	---

## PAPER 2

Q1	(a) $20 - 9 = 11$ (b) $4 \times 2 = 8$ $9 + 11 + 8 + 3 + 4 = 35$	Q2	$2 \times 3.14 \times (40 \div 2) = 125.6\text{cm}$ $125.6 \times 10 = 1256\text{cm}$
Q3	$100\% - 15\% = 85\%$ $85\% \rightarrow \$68$ $1\% \rightarrow \$0.80$ $100\% \rightarrow \$80$ $80 - 12 = \$68$	Q4	$390 \div 13 = 30$ $2250 \div 30 = 75\text{min}$
Q5	$83 + 34 + 35 + 36 + 37 + 38 = 213$ $6 \times 35.5 = 213$ Ans : 33	Q6	$7 - 1 = 6$ $6u : 36$ $1u : 6$ $8u : 48$ $48 + 12 = 60 \text{ workers}$
Q7	Diameter $\rightarrow 7\text{cm}$ Radius $\rightarrow 7 \div 2 = 3.5$ $1 \times 3.14 \times (7 \div 2) = 38.465\text{cm}^3$ $10 \times 7 = 70\text{cm}^2$ $\frac{1}{2} \times 6 \times 8 = 24\text{cm}^2$ $70\text{cm}^2 + 24\text{cm}^2 = 94\text{cm}^2$ $94\text{cm}^2 - 38.465\text{cm}^2 = 55.535 \text{ cm}^2$	Q8	$36.8 \div 5 = 7\text{R}1.8$ $29 \div 5 = 5\text{R}4$ $7 \times 5 = 35$
Q9	(a) $3 \times 7 = 21$ Length of Rope A is a multiple of 21 $21 \times 4 = 84$ $84 + 21 = 105$ $450 \div 105 = 4\text{R}30$ $105 \times 4 = 420$ $700 - 420 = 280\text{cm}$ (b) $700\text{cm} - 280\text{cm} = 420\text{cm}$	Q10	$MNL - LMN = 24$ $24 \times 2 = 48$ $180 - 48 = 132$ $132 \div 3 = 44$ $LMN = 44$ $180 - 44 - 44 = 92^\circ$
Q11	(a) $90 \div 2 = 45$ $380 - 45 - 45 - 60 - 75 = 135^\circ$ (b) $45 + 45 + 60 + 135 = 285$ $360 - 285 = 75$ $180 - 75 = 105^\circ$	Q12	(a) At first $\frac{\text{Chocolate}}{\text{Total}} \rightarrow \frac{40}{100} = 40\%$ In the end $\frac{\text{Chocolate}}{\text{Total}} \rightarrow \frac{40}{70} = 57.1$ Ans: Increase (b) $30u = 78$ $10u = 26$ $100u = 260$

Q13	<p>(a) 8a.m. → 8.06a.m.  <math>4l / \text{min} \times 6 = 24l</math>          (b) <math>80\text{cm} \times \frac{1}{4} = 20\text{cm}</math>  <math>3500 \times 20 \text{ cm} = 70\,000\text{cm}^3</math>  <math>70\,000 - 24\,000 = 46\,000\text{cm}^3</math>  <math>80\text{cm} \times 3500 = 280\,000\text{cm}^3</math>  <math>280\,000 - 46\,000 = 234l</math></p>	Q14	<p>(a) 1 Pencil + 1 eraser = \$1.05          8 Pencil + 5 eraser = \$6.90          5 Pencils + 5 erasers = \$5.25  <math>\\$6.90 \div \\$5.25 = \\$1.65</math>          3 Pencils = \$1.65          1 Pencil = \$0.55          (b) <math>\\$0.85 - \\$0.55 = \\$0.30</math>  <math>\\$3.30 \div \\$0.30 = 11</math></p>															
Q15	<p>(a) 5u : 35          1u : 7          4u : 28          (b) <math>35 \div 6 = 5R5</math>          5 clips → clips of 1 medium + 1 small          = (3 + 2) clips          5 boxes + 1 box + 1 box = 7 boxes</p>	Q16	<p>(a) <math>\frac{1}{4} + \frac{1}{4} + \frac{1}{2} = 1</math>  <math>1 \times 2 \times 3.14 \times 10 = 62.8\text{cm}</math>  <math>62.8\text{cm} + (10 \times 8) = 142.8\text{cm}</math>          (b) <math>\frac{1}{4} + \frac{1}{4} + \frac{1}{2} = 1</math>  <math>1 \times 3.14 \times 10 \times 10 = 314\text{cm}^2</math>  <math>10 \times 10 = 100\text{cm}^2</math>  <math>100\text{cm}^2 \times 4 = 400</math>  <math>400 + 314 = 714\text{cm}^2</math></p>															
Q17	<p>(a)          In Y,</p> <table border="1" data-bbox="322 936 788 1016"> <thead> <tr> <th>Gold</th> <th>Silver</th> <th>Total</th> </tr> </thead> <tbody> <tr> <td>3</td> <td>1</td> <td>4</td> </tr> </tbody> </table> <p>In Z,</p> <table border="1" data-bbox="322 1057 788 1173"> <thead> <tr> <th>Gold</th> <th>Silver</th> <th>Total</th> </tr> </thead> <tbody> <tr> <td>1</td> <td>4</td> <td>5</td> </tr> <tr> <td>4</td> <td>16</td> <td>20</td> </tr> </tbody> </table> <p><math>4 \times 5 = 20</math>  <math>20 \div 5 = 4</math>          Gold Y : Silver Z          3 : 16</p> <p>(b)  <math>6u + 24 = 9</math>  <math>9u - 6u = 3u</math>          3u : 8          1u : 8  <math>9 + 5 = 14u</math>          14u : 112</p> <p>(c)          1u : 8          Total units : <math>40 + 8 = 48</math>          Total tokens = <math>48 \times 8</math>          = 384</p>			Gold	Silver	Total	3	1	4	Gold	Silver	Total	1	4	5	4	16	20
Gold	Silver	Total																
3	1	4																
Gold	Silver	Total																
1	4	5																
4	16	20																

3  
 END