

2023 PRIMARY 5 END-OF-YEAR EXAMINATION

Name : _____ ()

Date: 26 October 2023

Class : Primary 5 ()

Time: 8.00 a.m. - 9.45 a.m.

Duration: 1 hour 45 minutes

SCIENCE BOOKLET A

INSTRUCTIONS TO CANDIDATES

1. Write your name, class and register number.
2. Do not turn over this page until you are told to do so.
3. Follow all instructions carefully.
4. Answer all questions.
5. Shade your answers on the Optical Answer Sheet (OAS) provided.

Booklet A (28 x 2 marks)

For each question from 1 to 28, four options are given. One of them is the correct answer. Make your choice (1, 2, 3 or 4) and shade your answer on the Optical Answer Sheet.

(56 marks)

1. The diagram below shows the fruits, X and Y.

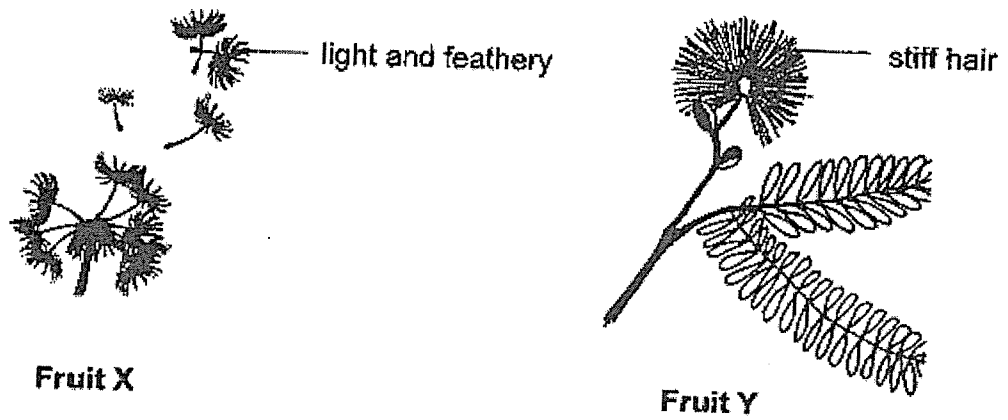

How are fruits X and Y dispersed?

	X	Y
(1)	animals	wind
(2)	wind	animals
(3)	wind	wind
(4)	animals	splitting

2. Elson observed three flowers, A, B and C, of the same plant.

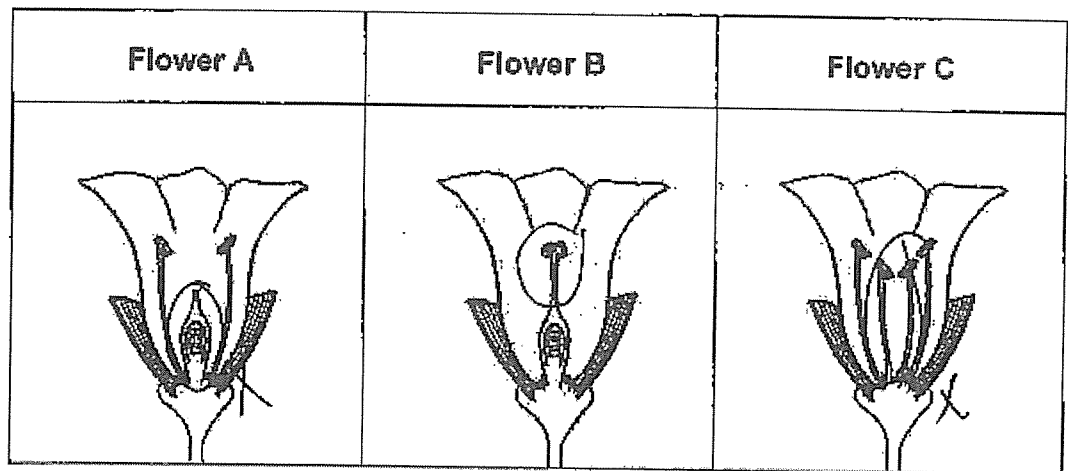

Which of the flower(s) is/are still able to develop into fruit(s)?

- (1) B only
 - (2) C only
 - (3) A and B only
 - (4) A, B and C
3. The diagram below shows the female reproductive system of a human.

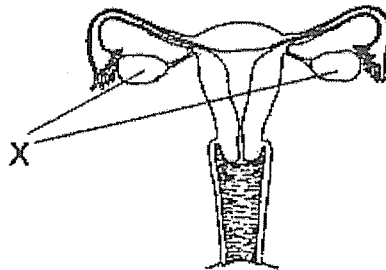

Which of the following statements is true when both parts X were removed?

- (1) No food will be provided for the baby.
- (2) There is no place for the baby to develop.
- (3) No eggs can be produced for fertilisation.
- (4) Eggs can still be produced for fertilisation.

4. The diagram shows a seedling.



David observed the seedling for a few days and plotted the graph below.

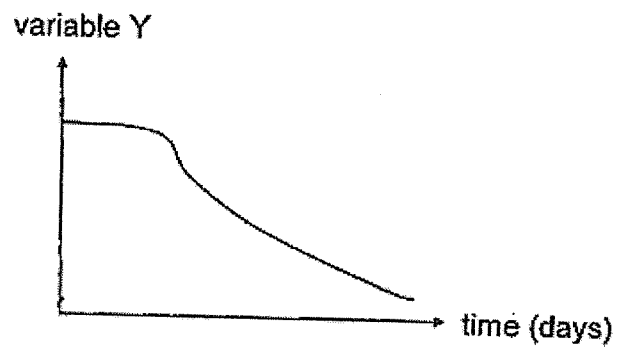

What could variable Y be?

- (1) Mass of the seedling
- (2) Height of the seedling
- (3) Average length of the root of the seedling
- (4) Average size of the seed leaves of the seedling

5. The table below shows the physical characteristics of four family members in the Kuah family.

	Mr Kuah	Mrs Kuah	Matthew (Son)	Melody (Daughter)
Hair length	Short	Long	Short	Short
Natural hair colour	Black	Brown	Brown	Black
Natural hair type	Wavy	Straight	Wavy	Wavy
Natural eye colour	Black	Brown	Brown	Brown

Based on the table, which of the following statements are true?

- A Melody inherited her hair length from her father.
 B Matthew inherited his hair colour and eye colour from his mother.
 C Melody and Matthew inherited their hair type from their father.

- (1) A and B only
 (2) A and C only
 (3) B and C only
 (4) A, B and C

6. A fish uses part X for gaseous exchange with the surroundings.

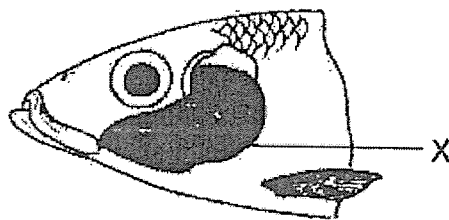

Which of the following statements about part X is incorrect?

- (1) Part X is filled with blood vessels.
 (2) Part X absorbs the oxygen dissolved in water.
 (3) Water flows over part X for exchange of gases.
 (4) Part X pumps blood rich in oxygen to all parts of the fish.

7. Aqil conducted an experiment using four set-ups. There was an equal volume of water in each container at the start of the experiment.

At the end of the experiment, he recorded his results as shown below.

Set-up	Exposed surface area of water in the container (cm ²)	Wind	Temperature (°C)	Volume of water left in the beaker (ml)
P	80	Present	36	190
Q	100	Present	25	210
R	80	Present	25	250
S	100	Absent	36	210

He concluded that the higher the temperature of surroundings, the higher the rate of evaporation. Based on his conclusion, which two set-ups did he use?

- (1) P and R
 - (2) P and S
 - (3) Q and R
 - (4) Q and S
8. The diagram below shows a water cycle.

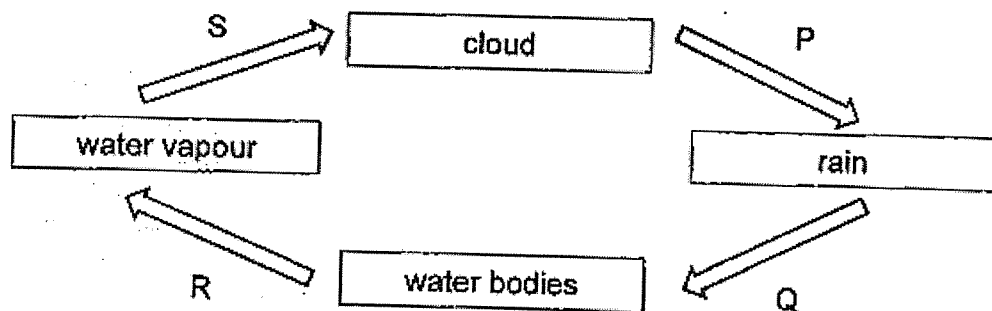

Which letter represents a process that involves a change in state due to heat loss?

- (1) P
- (2) Q
- (3) R
- (4) S

9. The table shows the states of four different substances, A, B, C and D, at different temperatures.

Which substance has the lowest boiling point?

	Substance	State of substance		
		At 8 °C	At 55 °C	At 85 °C
(1)	A	liquid	liquid	gas
(2)	B	solid	liquid	liquid
(3)	C	liquid	gas	gas
(4)	D	solid	solid	solid

10. Two cups of water were placed in a room which was at a room temperature of 30°C. The readings on the scale show the masses of the cup when they were placed on the digital weighing scale at first.

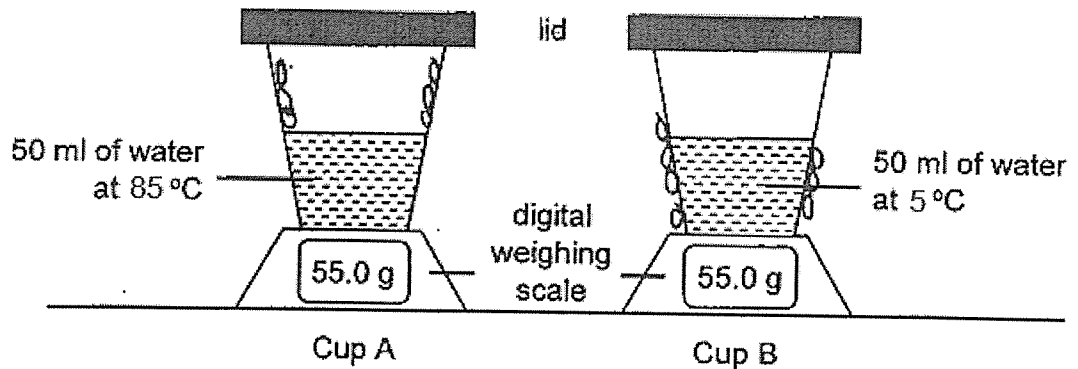

After five minutes, water droplets were observed at different parts of the cups.

Which of the following correctly shows the masses of the cups after five minutes?

	Cup A	Cup B
(1)	less than 55 g	more than 55 g
(2)	less than 55 g	remained the same
(3)	remained the same	remained the same
(4)	remained the same	more than 55 g

11. Four blood samples were taken from different blood vessels, J, K, L and M, in the human body. The graph shows the amount of carbon dioxide in the blood from each vessel.

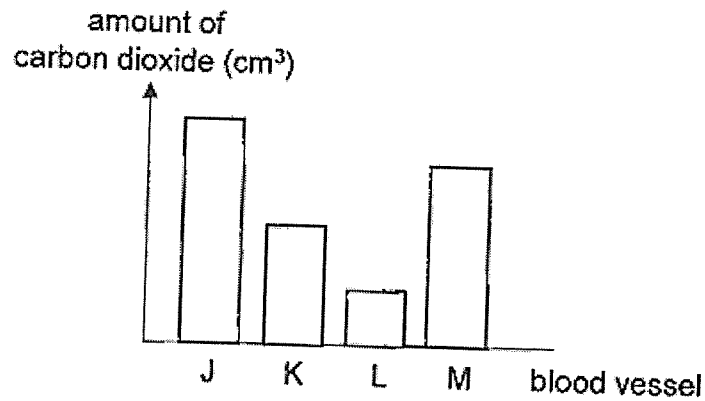

Which blood vessel was most likely carrying blood from the lungs to the heart?

- (1) J
 - (2) K
 - (3) L
 - (4) M
12. Joanna put a plant into a beaker of red-coloured water. A few hours later, she observed that the flowers turned from white to red.

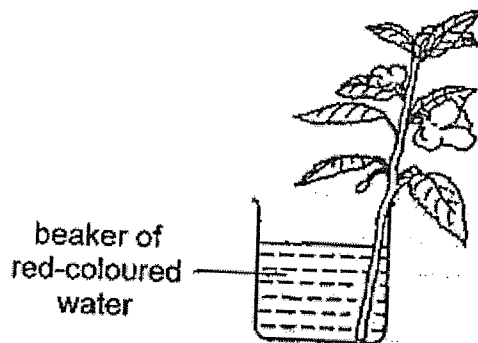

Which of the following explains her observation?

- (1) The water-carrying tubes transported the food to the flowers.
- (2) The food-carrying tubes transported the red-coloured water to the flowers.
- (3) The stem carries the red-coloured water through the water-carrying tubes to the flowers.
- (4) The red-coloured water is carried to the flowers via the food-carrying tubes and water-carrying tubes.

13. The diagram shows part of the stem of a small tree with a ring of the bark removed. Removing the ring of the bark takes away the food-carrying tubes but not the water-carrying tubes.

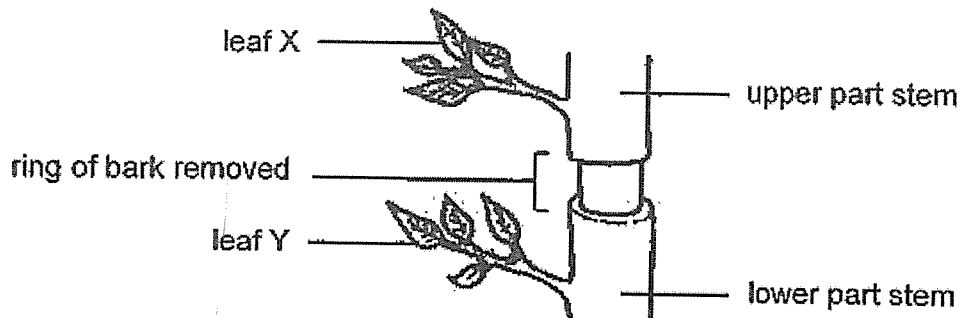

What will be the effect after some time when the ring of the bark is removed?

- (1) Leaf X will wilt because it cannot receive water from the roots.
 - (2) Leaf Y will wilt because it cannot receive food from the leaves above the ring.
 - (3) The lower part of the stem will be swollen because water is accumulated there.
 - (4) Both upper and lower parts of the stem will be swollen because food is accumulated there.
14. Study the three different cells below.

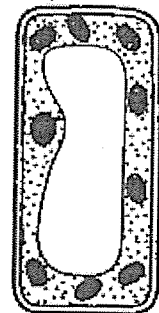
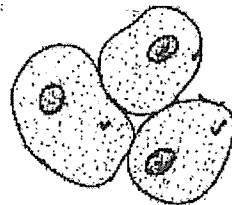
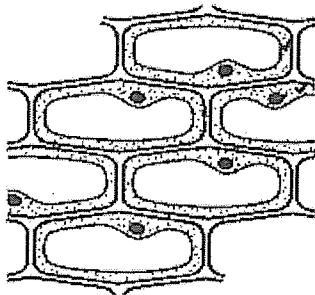

Which of the following parts are present in all the three cells shown above?

- (1) cytoplasm and cell wall
- (2) chloroplast and cytoplasm
- (3) cell membrane and cytoplasm
- (4) cell wall and cell membrane

15. Timmy cut a root into pieces of the same size. He placed each piece into a glass tube. Each root was placed in water at different temperatures.

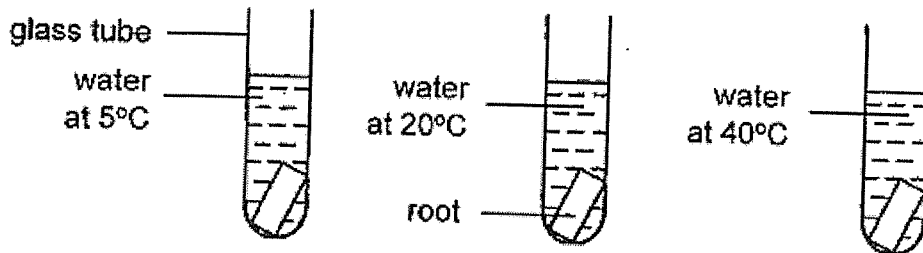

The root cells contained a red substance. After some time, Timmy observed the colour of the water in the tubes. The table below shows his results.

Temperature of water (°C)	Colour of water
5	light pink
20	pink
40	dark pink

Which of the following explains his observations?

	Temperature	Reason
(1)	low	Cell wall prevented more red substance from moving out.
(2)	high	Cell wall prevented more red substance from moving out.
(3)	low	Cell membrane allowed more red substance to move out.
(4)	high	Cell membrane allowed more red substance to move out.

16. The diagram shows a cylinder with a plunger attached. When the cylinder was filled with substance P, the plunger could be pushed down to a certain extent but not when it was filled with substance Q.

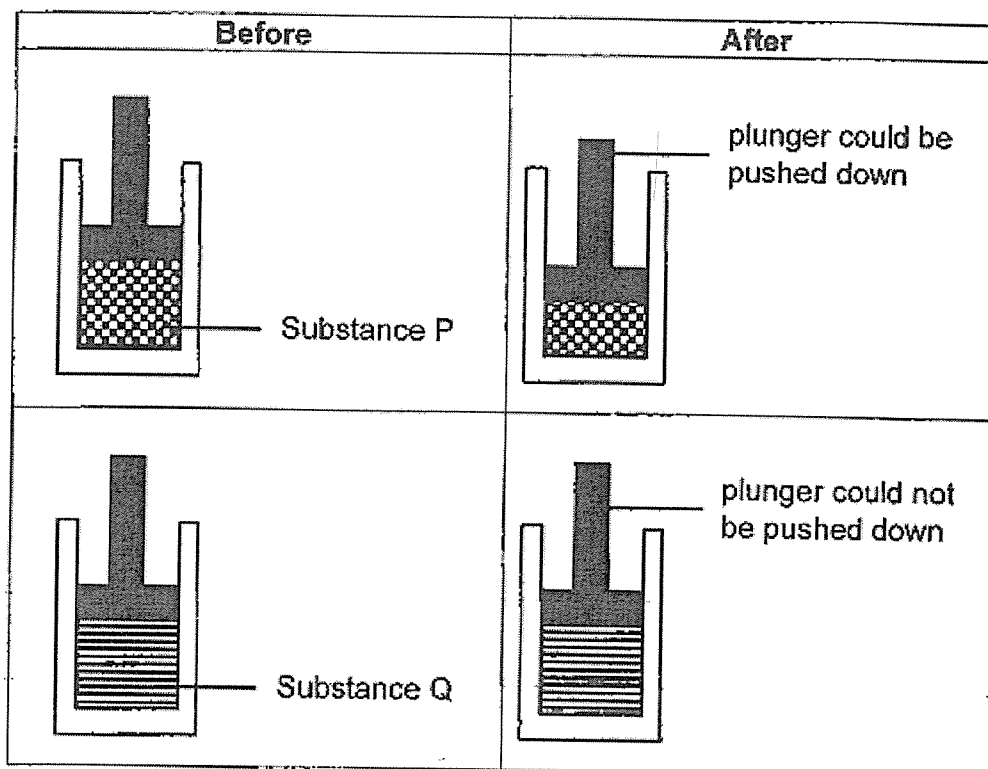

Based on the above observations, which of the following statements is definitely correct?

- (1) Substance Q has a definite volume.
- (2) Substance P does not have a definite shape.
- (3) Substance P is made up of a mixture of solid and liquid.
- (4) There were more air spaces between the particles in substance Q than substance P.

17. Amanda consumed 50 g of each type of food, P, Q, R and S.

The two graphs show the mass of undigested food P, Q, R and S, just before leaving the mouth and stomach.

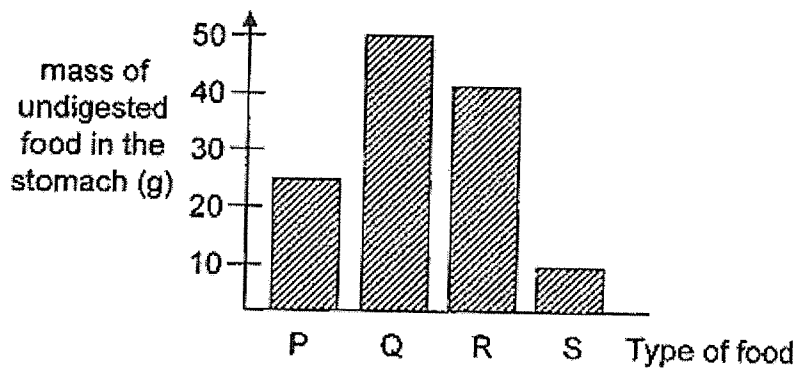
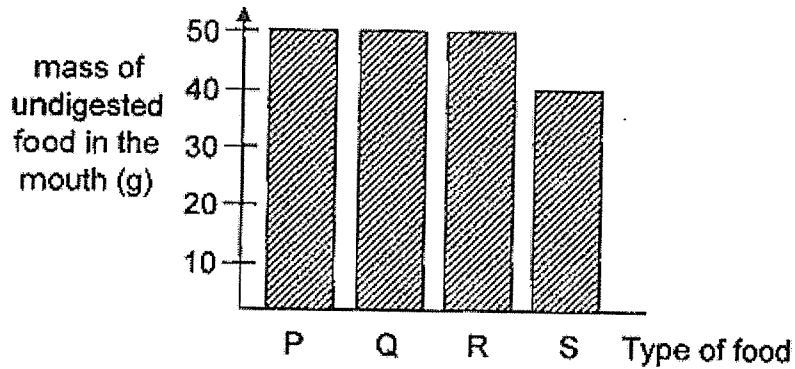

Based on the graphs above, which of the following statements about the digestion of food P, Q, R or S can be concluded from the graph?

- (1) P will be fully digested in the small intestine.
- (2) Q cannot be digested by the mouth or stomach.
- (3) R can only be digested by the mouth, and not the stomach.
- (4) S is digested more in the mouth than in the stomach.

18. Object M is placed between a boat and a stone wall of a harbour. M prevents damage to the boat. M is made from a material that can be compressed when the boat moves towards the harbour.

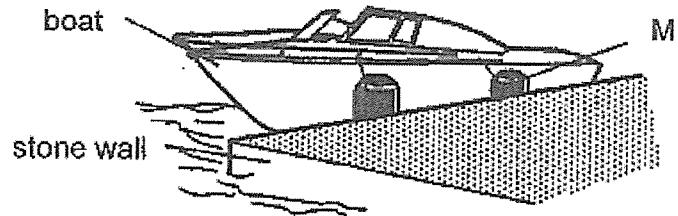

What are the properties of the material used to make M?

	Property		
	flexible	strong	waterproof
(1)	✓	✓	✓
(2)	✓	X	X
(3)	X	✓	✓
(4)	X	X	X

19. Sara hung objects Q, R and S in between a torch and a screen as shown below.

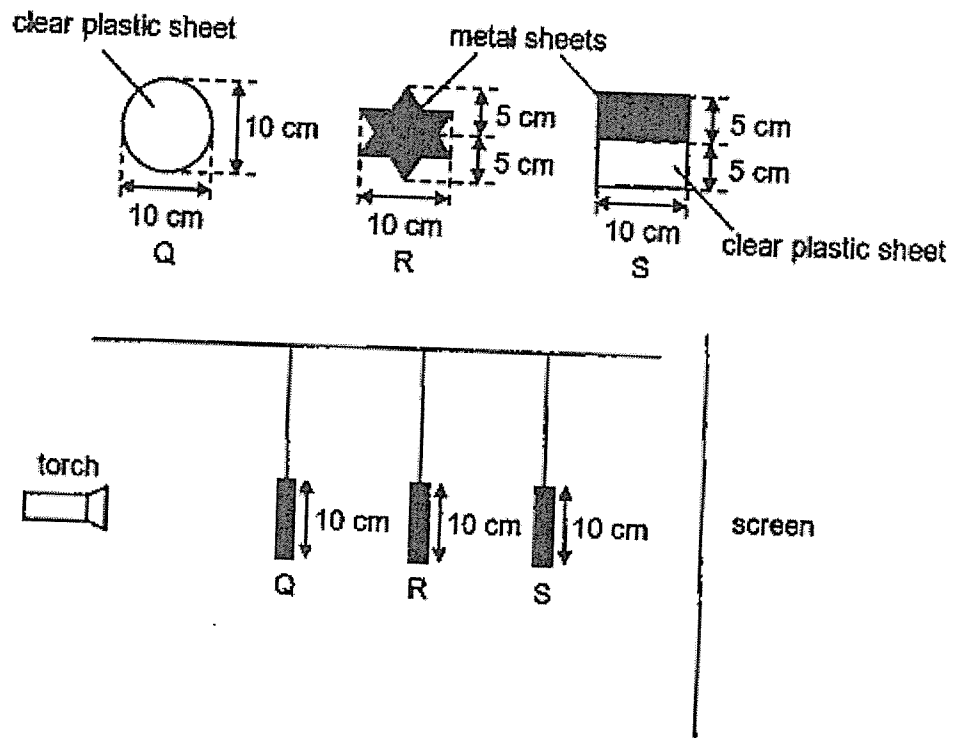

Which of the following would likely be seen on the screen when the torch is turned on?

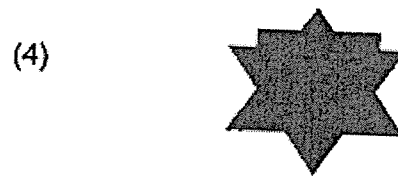
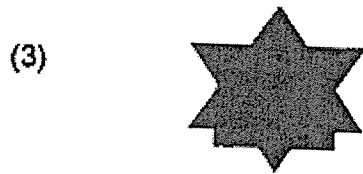
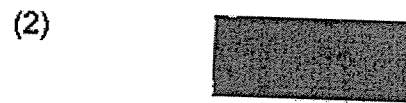
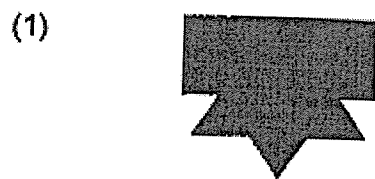

20. Aloysius placed an empty round-bottom flask into a basin of ice cubes as shown below.

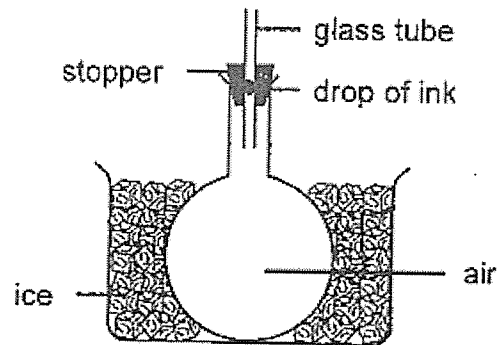

What did he observe after 20 minutes?

- (1) The drop of ink moved down the glass tube because air in the flask gained heat from the ice and expanded.
 - (2) The drop of ink moved up the glass tube because air in the flask gained heat from the ice and expanded.
 - (3) The drop of ink moved up the glass tube because air in the flask lost heat to the ice and contracted.
 - (4) The drop of ink moved down the glass tube because air in the flask lost heat to the ice and contracted.
21. The diagram below shows what happens during photosynthesis.

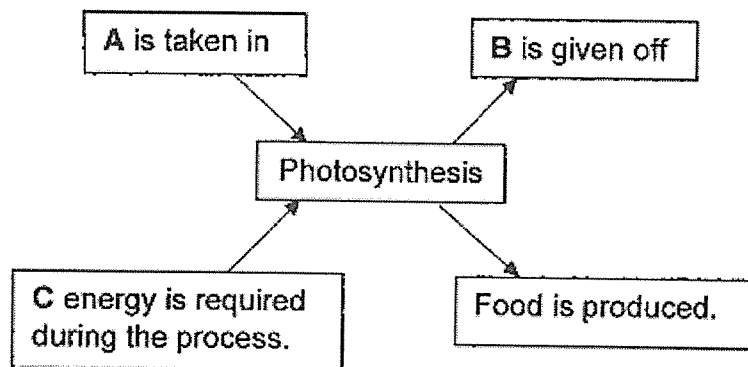

Which of the following, A, B and C, are represented correctly?

	A	B	C
(1)	oxygen	oxygen	heat
(2)	oxygen	carbon dioxide	light
(3)	carbon dioxide	oxygen	light
(4)	carbon dioxide	carbon dioxide	heat

22. Ismail placed two set-ups in the sun for 12 hours and gave both set-ups the same amount of water.

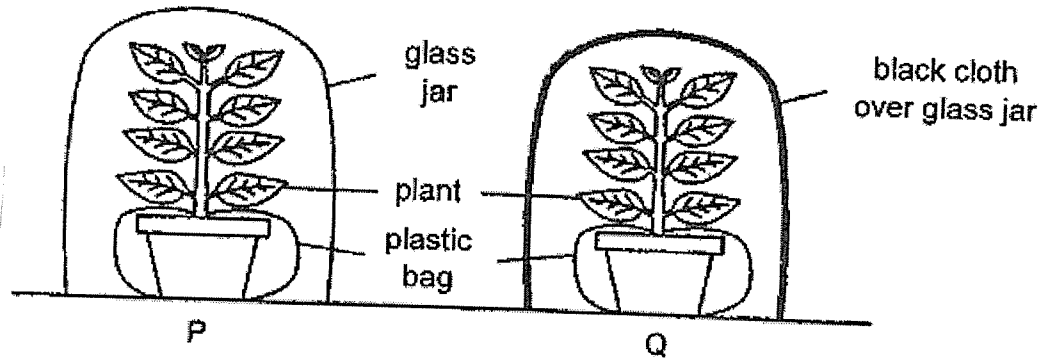

Which of the following correctly shows the amount of carbon dioxide in P and Q?

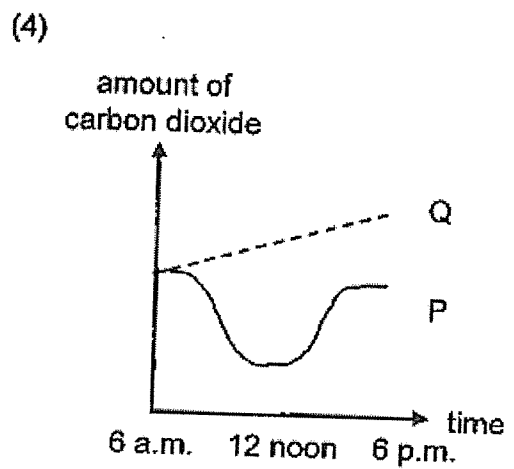
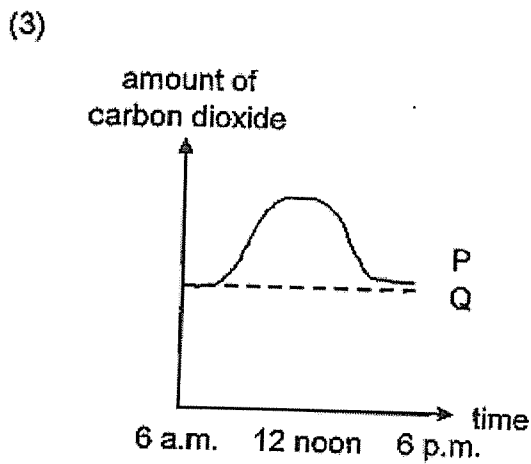
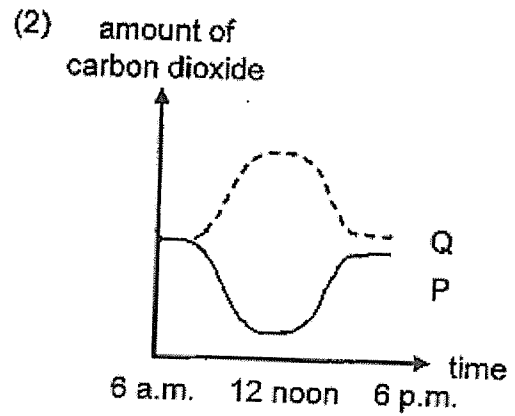
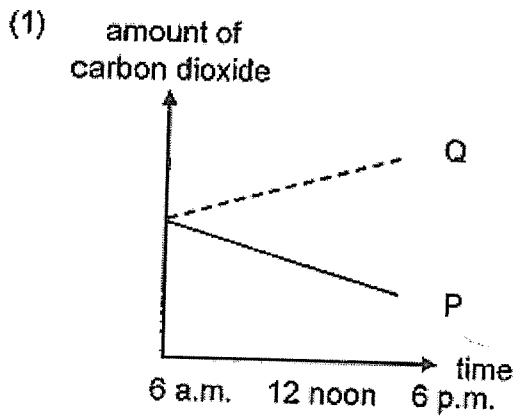

23. Three rods, P, Q and R, made of unknown materials, are placed in various positions in circuits A and B below.

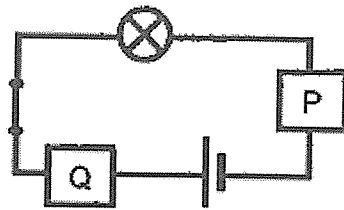

Circuit A

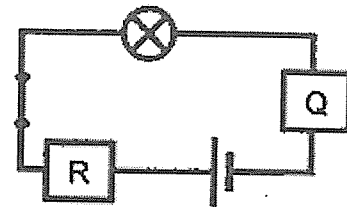

Circuit B

Only the bulb in Circuit B lit up.

What could materials P, Q and R be?

	material P	material Q	material R
(1)	iron	aluminium	plastic
(2)	rubber	plastic	iron
(3)	glass	iron	steel
(4)	steel	rubber	glass

24. The diagram below shows how four bulbs, two switches and four batteries are connected.

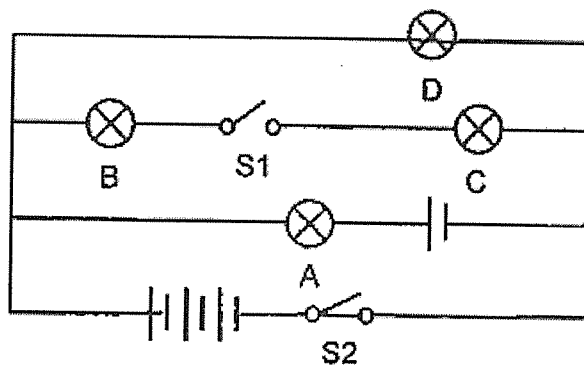

Which bulb(s) will light up when only switch S2 is closed?

- (1) D only
- (2) B and C only
- (3) A and D only
- (4) B, C and D only

25. Dorothy wanted to investigate the electrical conductivity of rods A, B, C and D.

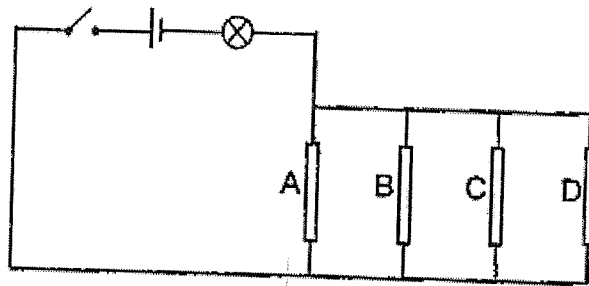

She removed certain rods and closed the switch. She recorded her observations below.

Rods removed from the circuit	Did the bulb light up?
A and D	Yes
B and C	No
B and D	Yes
A and C	No

Based on her observations, which of the rods is most likely an electrical conductor?

- (1) A
- (2) B
- (3) C
- (4) D

26. Xuan Ming constructed a circuit with two batteries, three bulbs and two switches. He closed one of the two switches and found that only two bulbs lit up. Which of the following is a possible circuit constructed by Xuan Ming?

(1)

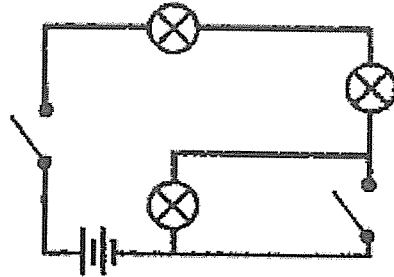

(2)

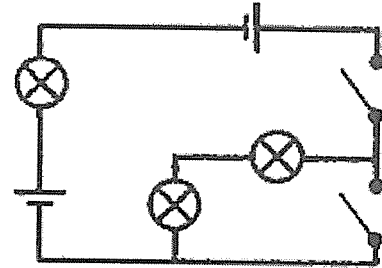

(3)

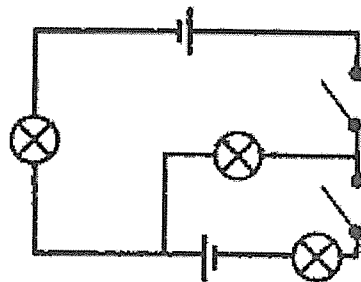

(4)

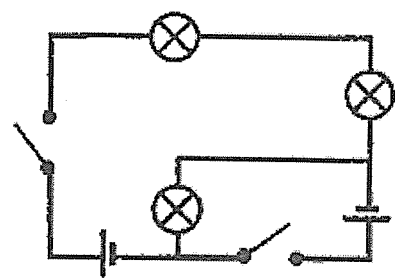

27. The diagram below shows an electromagnetic conveyor belt used to separate objects A and B.

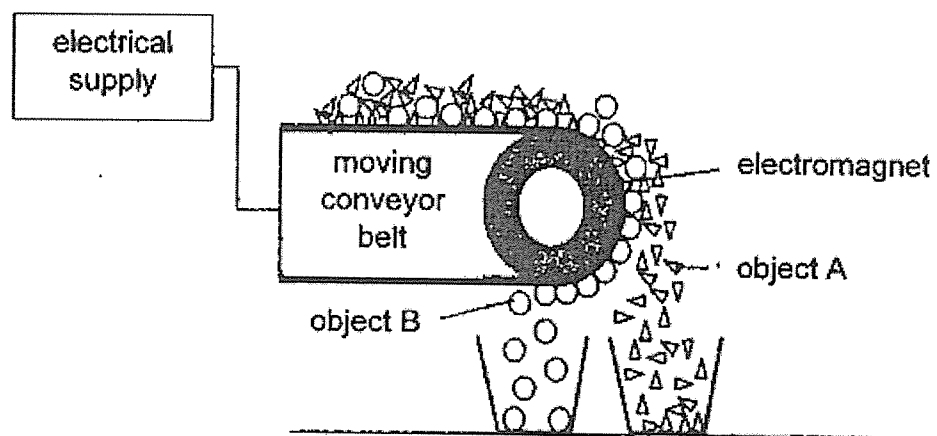

Based on the diagram, which of the following statements is true?

- (1) Both objects A and B are electrical conductors.
- (2) Both objects A and B are made of magnetic materials.
- (3) Object A is made of non-magnetic material and object B is made of magnetic material.
- (4) The moving conveyor belt is made of a strong magnet to attract both objects A and B.

28. Isaac set up an experiment as shown below.

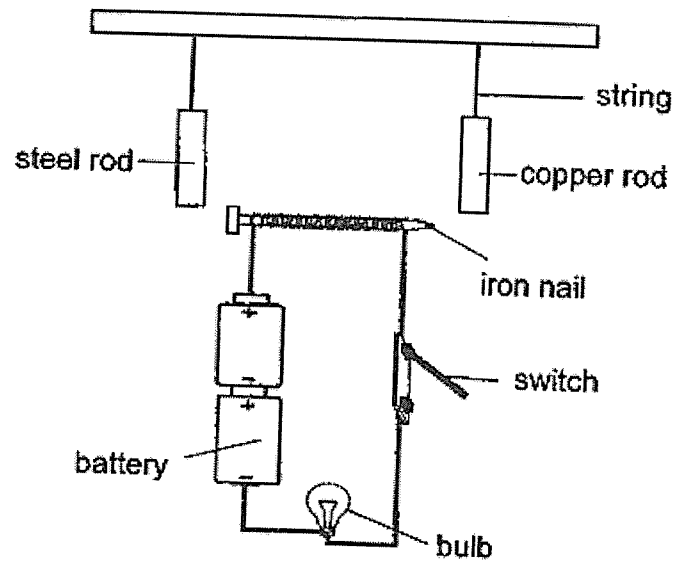

Which of the following are observed when he closes the switch?

- A The bulb lights up.
- B The steel rod moves towards the iron nail.
- C The copper rod remains stationary.

- (1) A and B only
- (2) A and C only
- (3) B and C only
- (4) A, B and C

End of Booklet A



2023 PRIMARY 5 END-OF-YEAR EXAMINATION

Name : _____ ()

Date: 26 October 2023

Class : Primary 5 ()

Time: 8.00 a.m. – 9.45 a.m.

Parent's Signature : _____

Duration: 1 hour 45 minutes

SCIENCE

BOOKLET B

INSTRUCTIONS TO CANDIDATES

1. Write your name, class and register number.
2. Do not turn over this page until you are told to do so.
3. Follow all instructions carefully.
4. Answer all questions.
5. Use a dark blue or black ballpoint pen to write your answers in the space provided for each question.
6. Do not use correction fluid/tape or highlighters.

Booklet A	56
Booklet B	44
Total	100

Booklet B (44 marks)

For questions 29 to 40, write your answers clearly in this booklet.

The number of marks available is shown in brackets [] at the end of each question or part question.

(44 marks)

29. The diagrams below show the reproductive systems of a plant and a human male.

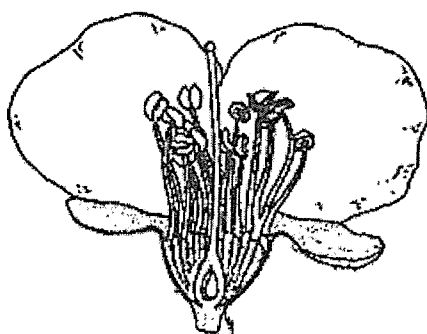

plant reproductive system

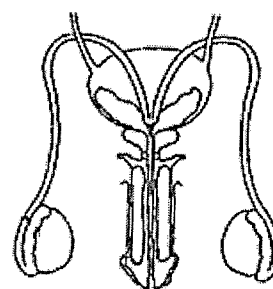

human male reproductive system

(a) Draw a line and mark with an "X" the part in the plant reproductive system where the male sex cell is produced. [1]



(b) Draw a line and mark with a "Y" the part in the human male reproductive system that carries out the same function as "X" in (a). [1]

(c) How does part Y help in the reproduction process? [1]

Score	3
-------	---

30. Julia added liquid T to both cells, A and B, and observed them under a microscope.

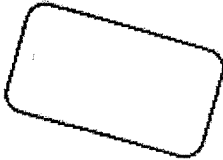
The table below shows her observations of the shape of the cells before and after liquid T was added.

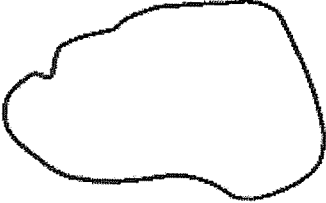
	Before adding liquid T	After adding liquid T
Cell A		
Cell B		

- (a) Based on her observations of the table above, Julia says that cell A is a plant cell. Do you agree? Explain your answer. [1]

- (b) Explain why cell B became bigger after adding liquid T. [1]

- (c) Julia continued to add more liquid T to cell B. What do you think will happen to cell B? [1]

31. Timothy observed the brightly-coloured flower of plant B and noticed that insect A is commonly found near it.



insect A

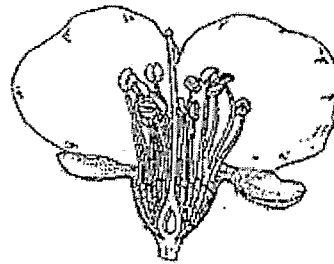

flower of plant B

- (a) Describe how insect A helps plant B to reproduce.

[1]

Timothy examined a flower from plant C as shown below.

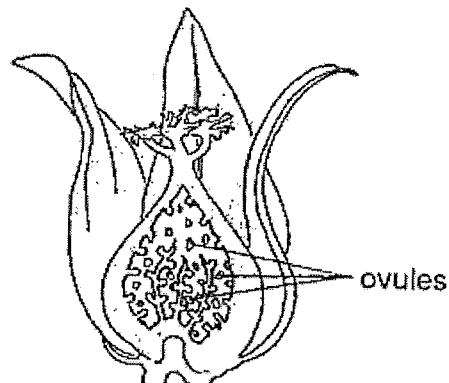

flower of plant C

He found fruits, D and E, near plant C.

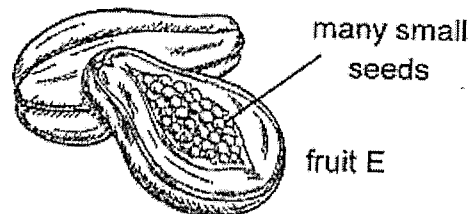
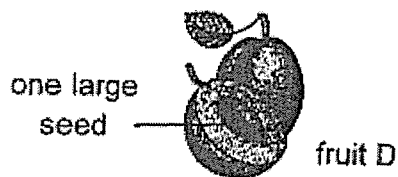

- (b) Which fruit, D or E, is most likely to be from flower C? Explain your answer.

[1]

Score	2
-------	---

(c) Explain the need for plants to produce as many seeds as possible. [1]

Score	1
-------	---

32. Abdul placed two set-ups near the window and gave them the same amount of water daily.

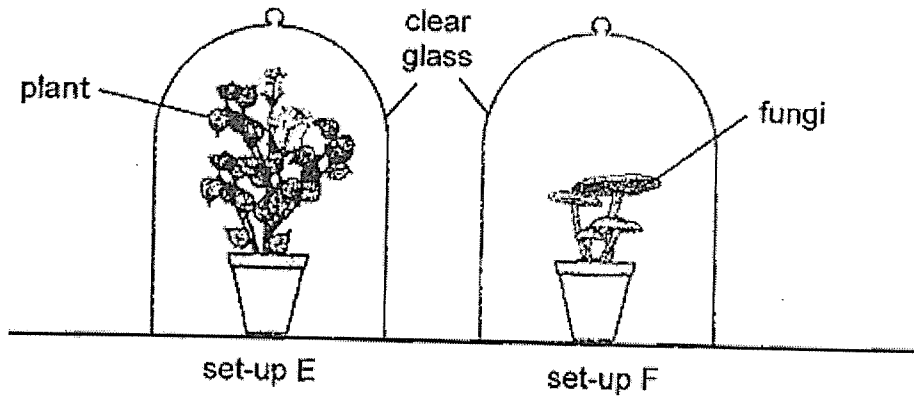

- (a) After a few days, which set-up had less oxygen? Explain your answer. [2]

Abdul then placed the same quantity of liquid X, which absorbs a particular gas, into each set-up. After a few days, Abdul noticed that the plant in set-up E died but the fungi in set-up F were still alive.

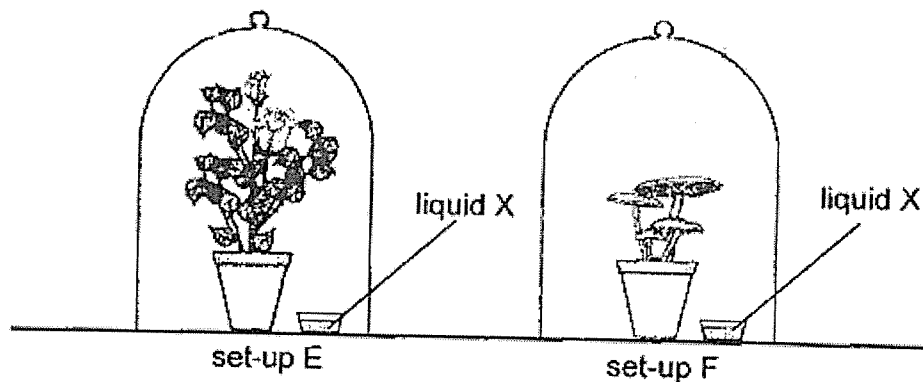

- (b) What gas did liquid X absorb? [1]

- (c) Explain why the plant in set-up E died. [1]

33. Suzie poured an equal volume of water into each of the two glasses, C and D, and placed them on a table at room temperature.

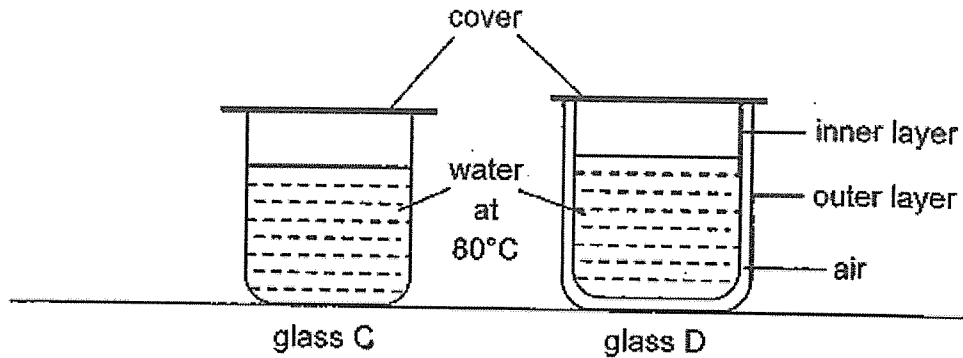

After 10 minutes, she measured the temperature of the water in each glass.

- (a) Will the temperature of the water in glass D be higher, the same or lower than the temperature of the water in glass C? Explain why. [2]

- (b) Suzie emptied the glasses, C and D, and poured an equal volume of water at room temperature into both glasses. She placed both glasses into the freezer. In which glass will the water freeze first? [1]

- (c) In the space below, using arrows "→", draw the direction of heat flow in the freezer for glass C. [1]

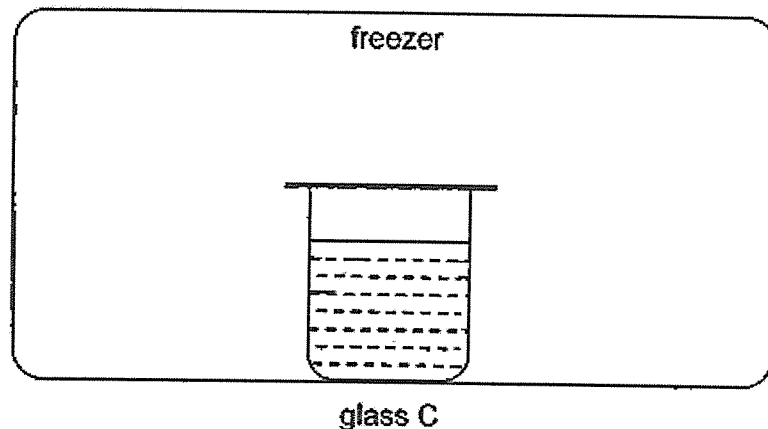

34. In the diagram below, the arrows represent the flow of blood in the human body.

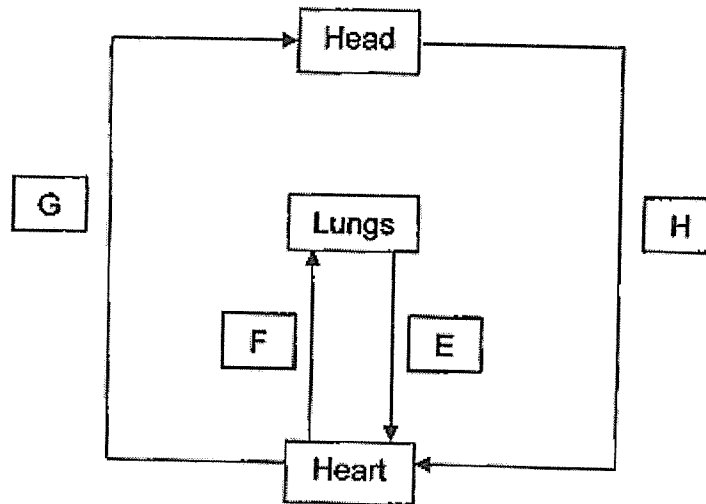

- (a) What is the difference in the amount of oxygen in the blood at E and F? [1]

- (b) Why is there less oxygen in the blood at H compared to G? [1]

- (c) Explain how the respiratory system works with the circulatory system to help a person run during a race. [2]

(d) The arrows show blood entering and leaving the small intestine.

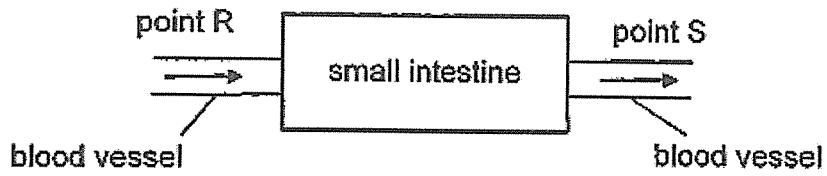

At which point, R or S, is there more digested food in the blood? Give a reason why. [1]

Score	1
-------	---

35. Nisa conducted an experiment to test a circuit card with a circuit tester. She recorded her observations in the table below.

Paper clips connected to the contact points on the circuit tester	Did the bulb light up?
A and F	Yes
B and E	No
C and D	Yes
C and F	Yes
D and F	Yes
E and F	No

- (a) Based on the information above, draw only two more lines in the circuit card below to show how the wires were connected. [1]

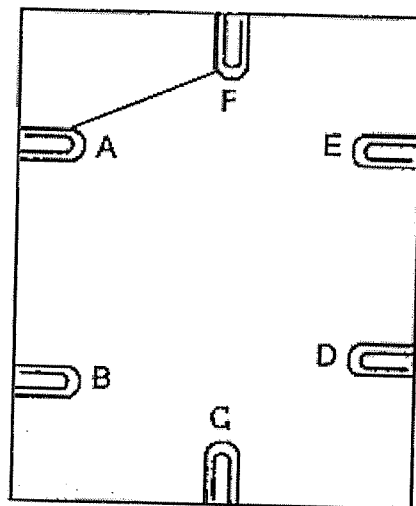

circuit card

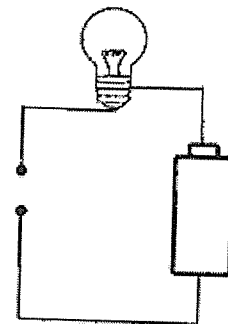

circuit tester

- (b) Explain why the bulb of the circuit tester did not light up when it is connected to paper clips, E and F. [1]

(c) In the space below, complete the circuit so that the following conditions are met.

- Both bulbs, when lit, are to be the brightest possible.
- Draw and label one switch, A, that controls bulb D.
- Draw and label one switch, B, that controls both bulbs.

[3]

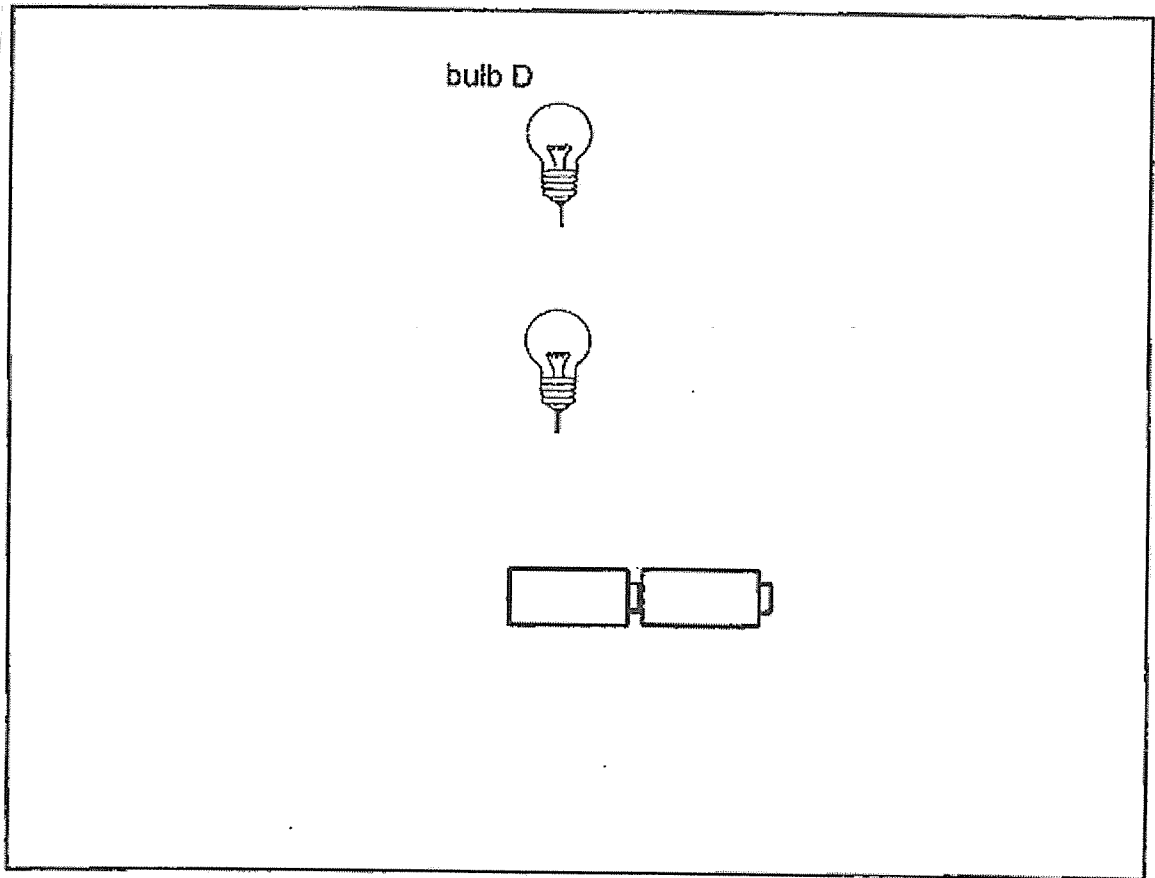

36. Fiona set up the experiment below in a dark room to find out whether different materials allow different amounts of light to pass through. When the torch was switched on, three sheets of different materials, F, G and H, were placed at position A, one at a time. The amount of light was measured using light sensors, N and P, placed at position A and the screen.

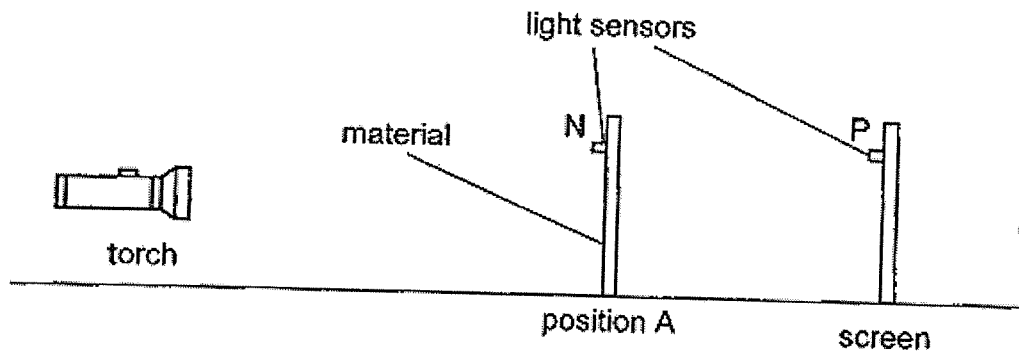

The flowchart below shows the properties of materials, F, G and H.

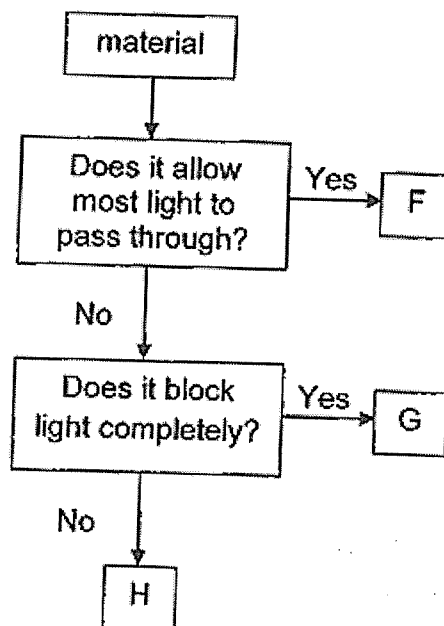

- (a) The results were recorded in the table below. Complete the table by filling in the correct materials and the appropriate values. [2]

Material at position A	Amount of light detected (units) by	
	Light Sensor N	Light Sensor P
G	600	_____
_____	600	550
_____	_____	200

Fiona then removed the light sensors and the materials. She placed a rectangular cardboard with a square hole in position A. When the torch was switched on, a patch of light was observed on the screen.

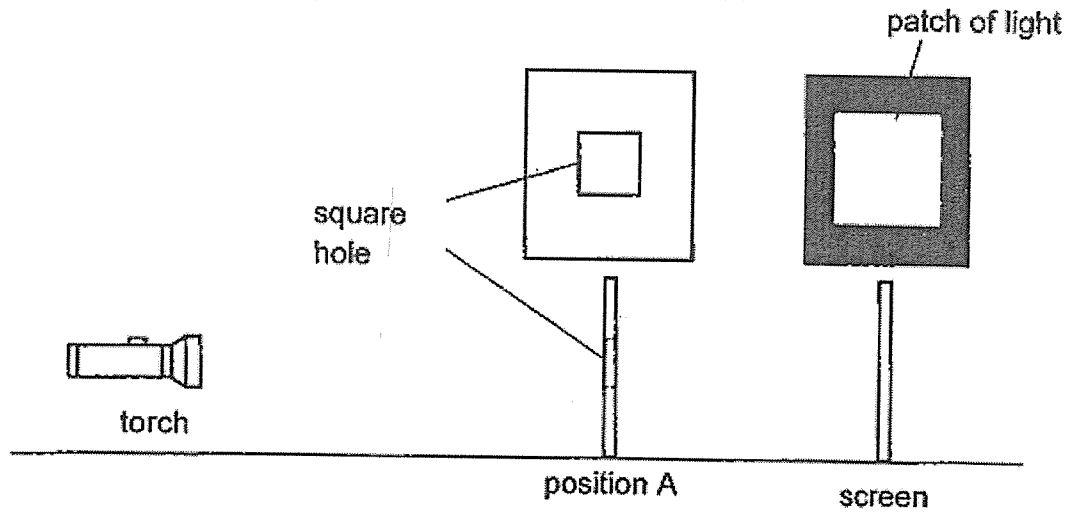

(b) State a property of light that allowed the patch of light to be seen on the screen [1]

(c) Without changing the apparatus used in the set-up above, what can Fiona do to decrease the size of the patch of light on the screen? [1]

37. Shafiq placed the set-up below in a room. He heated the water until it started boiling. After five minutes, Shafiq observed that water droplets formed on S and T and some water had collected in beakers Q and R as shown below.

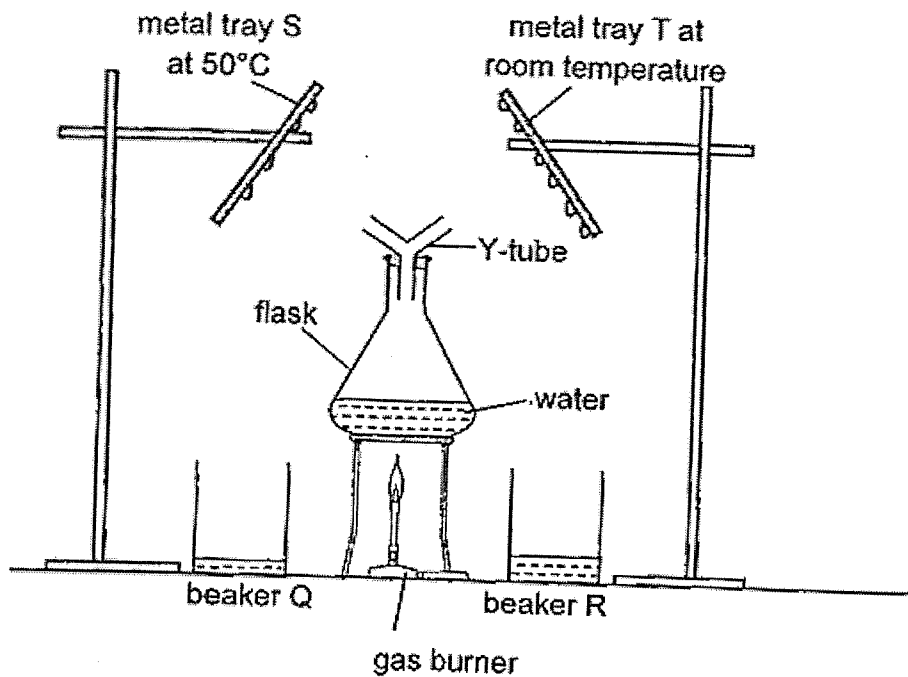

- (a) Based on the experiment above, state the process occurring to cause the water droplets forming on trays S and T. [1]

- (b) Explain why more water was collected in beaker R than in beaker Q. [1]

- (c) Suggest one way more water can be collected in the two beakers. [1]

38. The diagram below shows an experiment being carried out with three identical cubes made of different materials, X, Y and Z. They are placed into identical beakers, each containing 300ml of water.

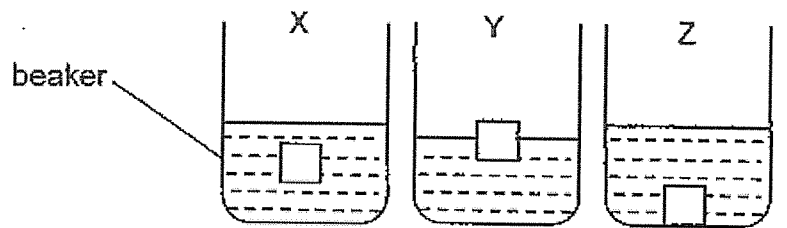

- (a) What property of the materials is being tested in the above setup? [1]
-

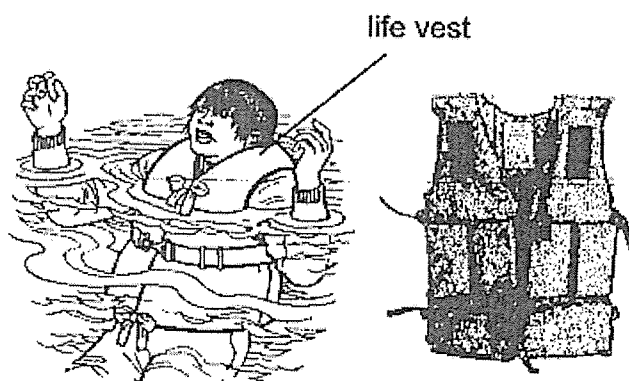

- (b) Which material, X, Y or Z, will be most suitable for making the life vest, as shown above, to keep the wearer alive? Explain why. [2]
-
-

39. Henry washed some bowls and plates and stacked them up to dry.

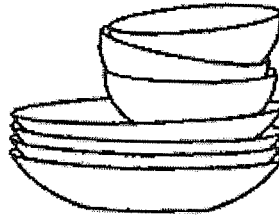

(a) After two hours, the bowls and plates were still wet. Explain why? [1]

(b) Without using a cloth to wipe them, suggest two sensible and possible ways that Henry can dry the bowls and plates faster. [2]

Score	3
-------	---

40. Thomas installed a light bulb inside his bathroom cabinet mirror such that when he slides the mirror aside, the light bulb lights up. The light bulb will switch off only when the mirror slides back fully.

He constructed the circuit for the sliding mirror as shown below. The metal ball, which is attached to the back of the mirror, slides along the tracks when the mirror is moved.

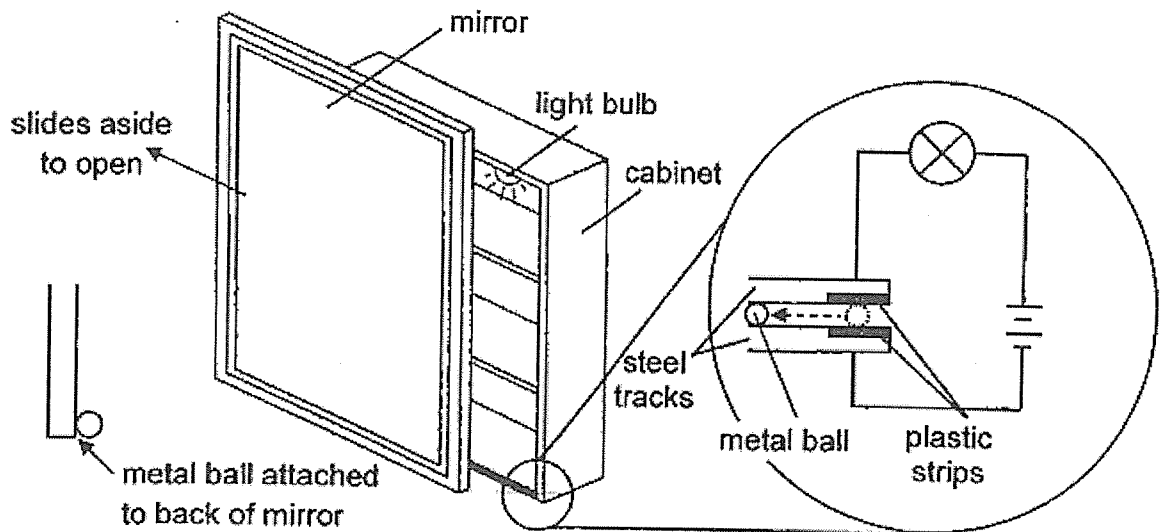

- (a) Explain why the light bulb will not light up when the metal ball is in contact with the plastic strips? [2]

- (b) After two days, Thomas found that he needed to change to new batteries as he did not slide the mirror to close fully and the bulb remained switched on for a long period of time. What changes can be done to the plastic strip to reduce the chances of this problem occurring again? Explain your answer. [2]

End of Paper

Score	4
-------	---

SCHOOL : TAO NAN SCHOOL
 LEVEL : PRIMARY 5
 SUBJECT : SCIENCE
 TERM : 2023 SA2

SECTION A

Q 1	Q2	Q3	Q4	Q5	Q6	Q7	Q8	Q9	Q10
2	1	3	4	3	4	1	4	3	4
Q 11	Q12	Q13	Q14	Q15	Q16	Q17	Q18	Q19	Q20
3	3	4	3	4	1	2	1	4	4
Q 21	Q22	Q23	Q24	Q25	Q26	Q27	Q28		
3	1	3	3	3	3	3	4		

SECTION B

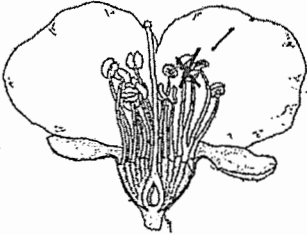
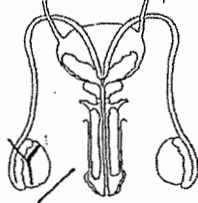
Q29a& b)	 <p>plant reproductive system</p>  <p>human male reproductive system</p>
Q29c)	Part Y stores the male reproductive cell for fertilisation to happen, where the sperm fuses with the egg.
Q30a)	I agree. After adding liquid T, the cell shape did not change. Plant cells have a cell wall, which fixes its shape. Therefore, A is a plant cell.
Q30b)	The cell membrane of B allowed liquid T to be absorbed and therefore, cell B became bigger.
Q30c)	Cell B would increase in size.
Q31a)	Insect A would transfer the pollen grains from the anther to the stigma of the same species of plant.
Q31b)	Fruit E. The flower of plant C has many ovules. The ovules when fertilised would become seeds. As C has many ovules, the fruit would have many seeds.

Q31c)	Plants produce many seeds to increase the chances of the seeds germinating into plants.
Q32a)	Set-up F. The plant photosynthesises and gives out oxygen. Fungi only respire and takes in oxygen.
Q32b)	Carbon dioxide
Q32c)	The plant in set-up E could not photosynthesise as there was no carbon dioxide left to produce sugar and therefore died.
Q33a)	The temperature in D would be higher as air is a poor conductor of heat. The water will lose heat slower to the surroundings.
Q33b)	C
Q33c)	Arrows pointing outwards from water
Q34a)	The blood at E contains more oxygen than the blood at F.
Q34b)	The head uses oxygen and gives out carbon dioxide to release energy for our activities.
Q34c)	Oxygen is taken in by the lungs and transported to all parts of the body.
Q34d)	Part S. The small intestine further digests food into simpler substances and is ready to be transported in the blood stream.
Q35a)	
Q35b)	There was an open circuit at E as the wires are not connected to E, hence, current was unable to flow through and light up the bulb.
Q35c)	
Q36a)	G: 600, 0 F: 600, 550 H: 600, 200

Q36b)	Light travels in a straight line.
Q36c)	Place cardboard closer to screen.
Q37a)	Condensation
Q37b)	Tray T is cooler than Tray S, hence water will condense faster on T, so more water was collected in R.
Q37c)	Add more ice on the tray.
Q38a)	Buoyancy OR ability to float or sink
Q38b)	Material Y. Y floats while X and Z sinks. This allows the wearer to float on water surface, so the wearer can breathe and would not drown.
Q39a)	The bowls and plates have very little exposed surface area to the environment which reduces the rate of evaporation of water.
Q39b)	Place them further apart. Put them under the Sun,
Q40a)	The plastic strip is an insulator and current cannot flow through it, making it an open circuit. Hence bulb will not light up.
Q40b)	Extend length of plastic strip. When the mirror is not fully closed, the metal ball will still be in contact with the plastic strip, so bulb would not light up.