

2023 PRIMARY 5 WEIGHTED ASSESSMENT 2

Name: _____ () Date: 21 August 2023

Class: Primary 5 () Duration: 1 h

Parent's Signature: _____ Marks: _____ / **30**

MATHEMATICS

INSTRUCTIONS TO CANDIDATES

1. Write your name, class and register number.
2. Do not turn over this page until you are told to do so.
3. Follow all instructions carefully.
4. Answer all questions.
5. Show your working clearly as marks are awarded for correct working.
6. Use a dark blue or black ballpoint pen to write your answers in the space provided for each question.
7. Do not use correction tape or highlighter for your solutions.
8. You are not allowed to use a calculator.

Section A

Short Answer Questions

Questions 1 to 10 carry 1 mark each. Write your answers in the spaces provided. For questions which require units, give your answers in the units stated. [10 marks]

1. Round 6.495 to the nearest hundredth.

Ans: _____

2. Find the value of $2\frac{1}{3} + 1\frac{7}{8}$.

Express your answer as a mixed number in its simplest form.

Ans: _____

3. John and his 29 friends share \$9 equally.
How much will each person get?

Ans: \$ _____

4. What is the missing number in $14 : \square : 18 = 7 : 6 : 9$?

Ans: _____

5. Siti is 11 years old. Ali is 7 years old.
Find the ratio of Ali's age to Siti's age in 4 years' time.

Ans: _____

6. Mr Lee drove from Singapore to Penang.
He arrived at Penang at 02 30 on Saturday. The journey took 7 h 40 min.
What time did Mr Lee leave Singapore on Friday?
Express your answer using the 24-h clock.

Ans: _____

7. Name the base that is related to the height CE of the triangle.

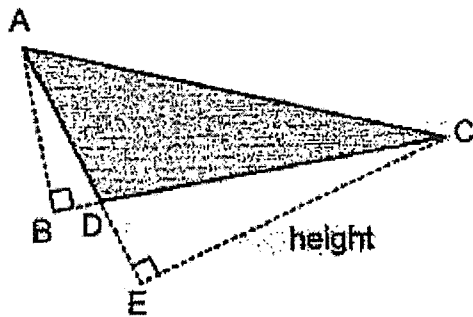

Ans: _____

8. The figure is made up of a square, a rectangle and a triangle. Given that the square has a side of 8 cm, find the area of the figure.

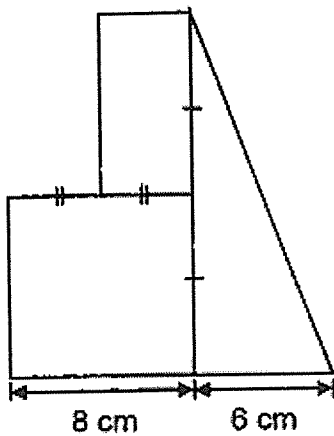

Ans: _____ cm²

9. The solid figure is formed using unit cubes. What is the volume of the solid?

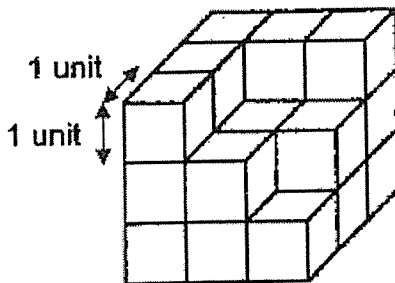

Ans: _____ cubic units

10. Bottle P has $\frac{5}{8}$ ℓ of juice. Bottle Q has 480 mL of juice.

Find the total volume of juice in the two bottles.

Give your answer in litres and millilitres.

Ans: _____ ℓ _____ mL

Section B

For questions 11 to 15, show your working clearly and write your answers in the spaces provided. The number of marks available is shown in brackets [] at the end of each question or part-question. **[20 marks]**

11. The figure is made up of 4 identical squares.

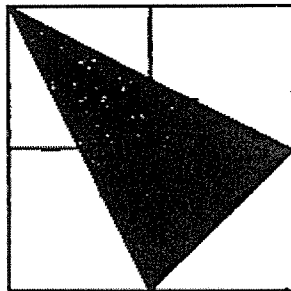

(a) What is the ratio of the shaded parts to the figure?

Ans: _____ [1]

(b) If the area of the shaded part is 21 m^2 , find the area of the total figure.

Ans: _____ [2]

12. Suping cut out 2 squares, A and C, and 2 rectangles, B and D, from a rectangular piece of cloth.

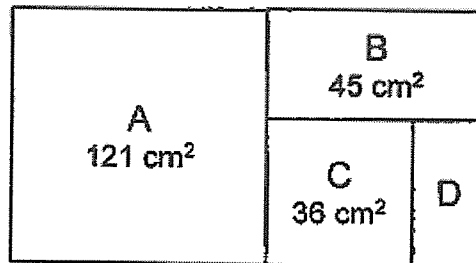

- (a) Find the perimeter of square A.

Ans: a) _____ [1]

- (b) Find the area of rectangle D.

Ans: b) _____ [2]

13. A rectangular tank measuring 50 cm by 30 cm by 8 cm is $\frac{3}{4}$ filled with water. The water is then transferred into a cubical container of edge 25 cm. How much more water is needed to fill the cubical container to the brim? Give your answer in millilitres.

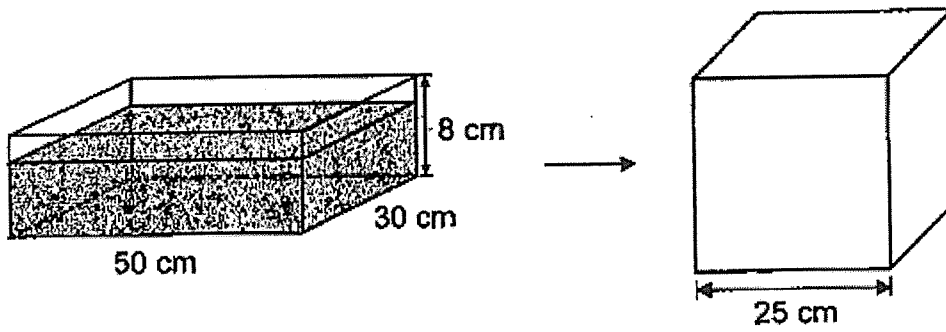

Ans: _____ [4]

14. The mass of 2 watermelons and 3 papayas is 9.6 kg.
The mass of 3 watermelons and 5 papayas is 14.8 kg.
Each watermelon has the same mass and each papaya has the same mass.
- (a) What is the mass of 1 papaya? Give your answer in kilograms.

Ans: a) _____ [2]

- (b) What is the total mass of 2 watermelons and 1 papaya? Give your answer in kilograms.

Ans: b) _____ [3]

15. At a farm, $\frac{2}{7}$ of the animals and another 14 animals are rabbits.
 $\frac{1}{3}$ of the remaining animals and another 29 animals are cows.
The rest of the animals are goats. There are 65 goats at the farm.
a) How many cows are at the farm?

Ans: a) _____ [2]

- b) Find the total number of animals at the farm.

Ans: b) _____ [3]

End of Paper

SCHOOL : TAO NAN PRIMARY SCHOOL

LEVEL : PRIMARY 5

SUBJECT : MATH WA2

TERM : (2023)

1)	6.50
2)	$4\frac{5}{24}$
3)	\$0.30
4)	12
5)	11:15
6)	1850
7)	AD
8)	144cm ²
9)	22
10)	1L 105ml
11)	a)3:8 b)21 ÷ 1.5 = 14 14 x 4 = 56m ²
12)	a) $\sqrt{121} = 11$ 11 x 4 = 44cm b) $\sqrt{36\text{cm}^2} = 6\text{cm}$ 45cm ² = 9 x 5cm = 9 - 6 = 3 3 x 6 = 18cm ² The area of rectangle D is 18cm ²

13)	$\frac{3}{4} \times 50 \times 30 \times 8 = 9000$ $15625 - 9000 = 6625$
14)	a) 0.8kg b) 8kg
15)	a) 76 b) 217