



**Anglo-Chinese School
(Primary)**

A Methodist Institution
(Founded 1886)

**Mathematics
Weighted Assessment
2023
Quiz 2
Paper 1**

Name: _____ () Date: _____

Class: Pr 5 ____

Duration: 15 minutes

INSTRUCTIONS TO CANDIDATES

1. This question paper consists of 5 printed pages, including the cover page.
2. Do not turn this page until you are told to do so.
3. Follow all instructions carefully.
4. Answer all questions.
5. You are not allowed to use a calculator.

Section	Maximum Marks	Marks Obtained
Paper 1		
MCQ and Short Answers	9	
Paper 2		
Problem Sums	21	
Total Marks	30	

Section A:

Questions 1 to 3 carry 1 mark each. For each question, four options are given. One of them is the correct answer. Choose the correct answer and write its number in the brackets provided. (3 marks)

1. Find the value of $\frac{3}{4} \times \frac{6}{9}$.

1) $\frac{1}{2}$

2) $\frac{1}{4}$

3) $\frac{1}{18}$

4) $\frac{9}{13}$

()

2. Andrew drew a house using circles, triangles and rectangles. What is the ratio of the number of circles to the number of triangles to the total number of circles, triangles and rectangles?

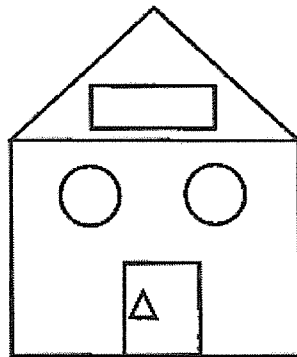

1) 1 : 1 : 3

2) 1 : 1 : 7

3) 2 : 2 : 3

4) 2 : 2 : 7

()

3. In the figure below, the length of the rectangle 16 cm and its height is 6 cm. The length of AD is 10 cm and $CD = DE$. Find the area of the shaded triangle.

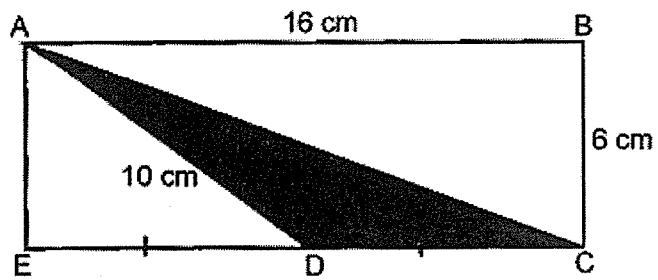

- 1) 24 cm²
- 2) 30 cm²
- 3) 40 cm²
- 4) 48 cm²

()

Section B:

Questions 4 to 6 carry 2 marks each. Show your mathematical statements clearly in the space provided for each question. Write your answers in the spaces provided. Give your answers to the units stated and to its simplest form whenever necessary. (6 marks)

4. The rectangle below is made up of 8 identical squares.

The height of the rectangle is $\frac{1}{3}$ m. Find the area of the rectangle.

Give your answer as a fraction in its simplest form.



Ans: _____ m²

5. There are some apples in a box. For every 5 good apples, there are 2 rotten ones. There are 55 good apples in the box. Find the total number of apples in the box.

Ans: _____

6. The square below is made up of 8 identical rectangles and 8 identical shaded triangles. Find the total area of the shaded triangles.

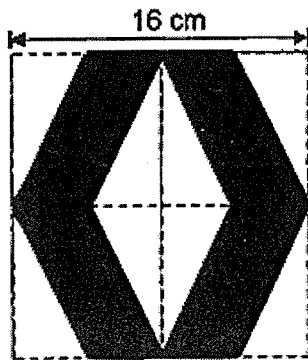

Ans: _____ cm²

- End of Paper 1 -



Anglo-Chinese School
(Primary)
A Methodist Institution
(Founded 1886)

Mathematics
Weighted Assessment
2023
Quiz 2
Paper 2

Name: _____ () Date: _____

Class: Pr 5 ____

Duration: 40 minutes

INSTRUCTIONS TO CANDIDATES

1. This question paper consists of 7 printed pages, including the cover page.
2. Do not turn this page until you are told to do so.
3. Follow all instructions carefully.
4. Answer all questions.
5. You are allowed to use a calculator.

Section C:

For questions 7 to 12, show your mathematical statements clearly in the space provided for each question. Write your answers in the spaces provided. Give your answers to the units stated and to its simplest form whenever necessary. (21 marks)

7. A box contained some potatoes. After Mr Tan used $2\frac{3}{5}$ kg of potatoes and added in another $\frac{2}{3}$ kg, there were 5 kg of potatoes left in the box. What was the mass of the potatoes in the box at first?

Ans: _____ kg [2]

8. A piece of ribbon was cut into three pieces in the ratio 3 : 4 : 7.
The longest piece is 112 cm longer than the shortest piece. Find the original length
of the piece of ribbon. Give your answer in centimetres.

Ans: _____ [3]

9. Two big triangles BFG and DFG are drawn in rectangle AEFB as shown below. The total area of triangle BCG and triangle CDF is 127.6 cm^2 . Find the area of triangle CFG.

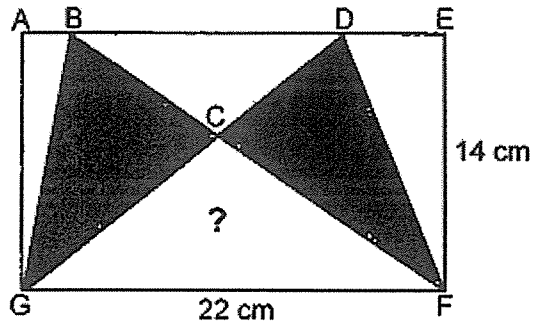

Ans: _____ [3]

10. Adele had 3 identical boxes, Box A, Box B and Box C. Box A was contained 65 cubes. The ratio of the number of cubes in Box A to the number of cubes in Box B was 5 : 3.
- (a) Find the number of cubes in Box B.
 - (b) After Adele took some cubes out of Box A, the ratio of the number of cubes in Box A to the number of cubes in Box C became 5 : 6. The number of cubes in Box C was more than 50 and less than 60. How many cubes were left in Box A in the end?

Ans: (a) _____ [2]

(b) _____ [2]

11. The figure below is made up of a big square and 2 small identical squares. The side of the big square is 20 cm and the side of the small square is 14 cm. BCD is a straight line.
- (a) Find the area of triangle ACD.
- (b) Find the area of triangle ABC.

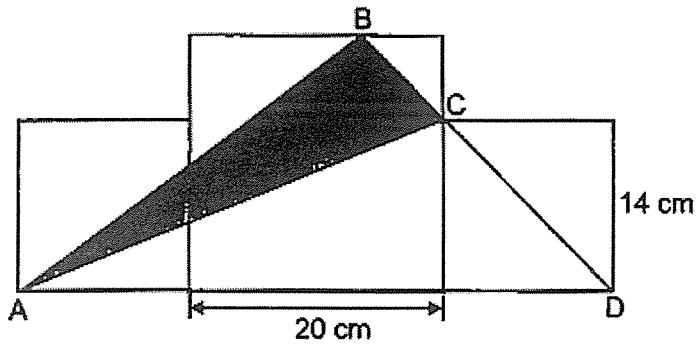

Ans: (a) _____ [2]

(b) _____ [2]

12. Anan and Jia Qi had the same amount of money at first. After Anan spent $\frac{1}{4}$ of his money and Jia Qi spent $\frac{7}{8}$ of her money, Anan had \$300 more than Jia Qi.
- (a) How much money did Anan have left?
- (b) Anan gave $\frac{2}{5}$ of the money he had left to his mother and $\frac{1}{3}$ of the remainder to his father. How much money did Anan give to his father?

Ans: (a) _____ [3]

(b) _____ [2]

- End of Paper 2 -

SCHOOL : ACS PRIMARY SCHOOL
LEVEL : PRIMARY 5
SUBJECT : MATHEMATICS
TERM : 2023 WEIGHTED ASSESSMENT QUIZ 2

PAPER 1 (SECTION A)

Q 1	Q2	Q3
1	4	1

PAPER 1 (SECTION B)

Q4	Length of rectangle = $2 \times \frac{1}{3} = \frac{2}{3}$ Area = $\frac{1}{3} \times \frac{2}{3} = \frac{2}{9} \text{ m}^2$
Q5	$55 \div 5 = 11$ $11 \times 2 = 22$ $22 + 55 = 77$
Q6	$16 \div 2 = 8$ $8 \times 16 = 128 \text{ cm}^2$

PAPER 2

Q7	$5 - \frac{2}{3} = 4\frac{1}{3}$ $4\frac{1}{3} + 2\frac{3}{5} = 6\frac{14}{15} \text{ kg}$
Q8	$7u - 3u = 4u$ $4u = 112$ $1u = 28$ $14u = 28 \times 14 = 392 \text{ cm}$
Q9	Area of 1 shaded $\triangle = 127.6 \div 2 = 63.8$ Area of $\triangle DFG = 0.5 \times 22 \times 14 = 154 = \text{Area of } \triangle BFG$ $154 - 63.8 = 40.2 \text{ cm}^2$
Q10a	$5u = 65$ $1u = 13$ $3u = 3 \times 13 = 39$

Q10b	$54 \div 6 = 9$ $9 \times 5 = \mathbf{45}$
Q11a	$14 \times 14 = 196$ $196 \div 2 = 98$ $0.5 \times (20 + 14) \times 14 = 238$ $238 + 98 = \mathbf{336 \text{ cm}^2}$
Q11b	$0.5 \times 20 \times 48 = 480$ $480 - 336 = \mathbf{144 \text{ cm}^2}$
Q12a	$2u \times 3 = 6u$ $6u - 1u = 5u$ $5u = \$300$ $1u = \$60$ $6u = \$60 \times 6 = \mathbf{\$360}$
Q12b	$\$360 \div 5 = \72 $5 - 2 = 3$ $\$72 \times 3 = \216 $\$216 \div 3 = \mathbf{\$72}$