

Name: ..... Index no.: ..... Class.....

**Bukit Batok Secondary School****GCE O LEVEL PRELIMINARY EXAMINATIONS 2022  
SECONDARY 4 EXPRESS****PHYSICS**

Paper 1 Multiple Choice

6091/01

31 Aug 2022

1 Hour

1005 – 1105 h

Additional Materials: Multiple Choice Answer Sheet (OAS)

**READ THESE INSTRUCTIONS FIRST**

Write in soft pencil.

Do not use staples, paper clips, glue or correction fluid.

Write your name, index number and class in the spaces provided at the top of this page.

There are **forty** questions on this paper. Answer **all** questions. For each question there are four possible answers **A, B, C** and **D**.Choose the **one** you consider correct and record your choice in **soft pencil** on the OAS.

Each correct answer will score one mark. A mark will not be deducted for a wrong answer.

Any rough working should be done in this booklet.

The use of an approved scientific calculator is expected, where appropriate.

---

This Question paper consists of 17 printed pages including this cover page.

1 What is the conversion factor for converting gigametres (Gm) to millimetres (mm)?

- A  $10^3$       B  $10^6$       C  $10^9$       D  $10^{12}$

2 Two forces,  $F_1$  and  $F_2$ , act on a particle as shown.

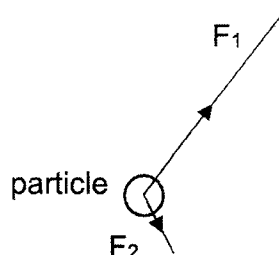

Which diagram correctly shows the force  $F_3$  that would keep the particle stationary?

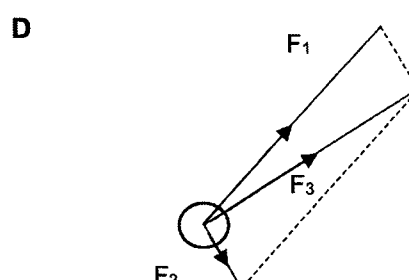
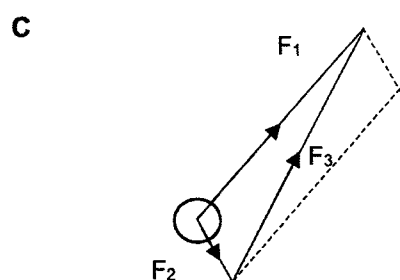
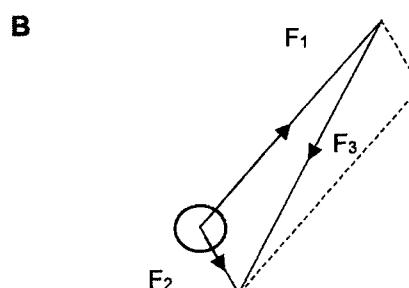
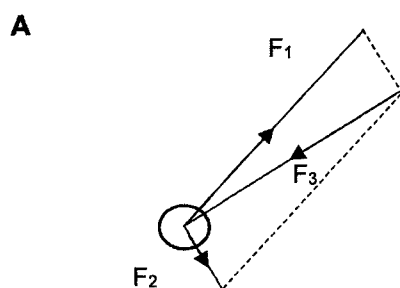

3 An object is falling under gravity with terminal velocity.

Which of the following statements is correct?

- A The acceleration of the object will decrease to zero.  
 B The force on the object due to air resistance will decrease to zero.  
 C The resultant force on the object is zero.  
 D The speed of the object will decrease at a constant rate to zero.

- 4 The diagram shows the displacement-time graph of a car traveling on a straight, horizontal road.

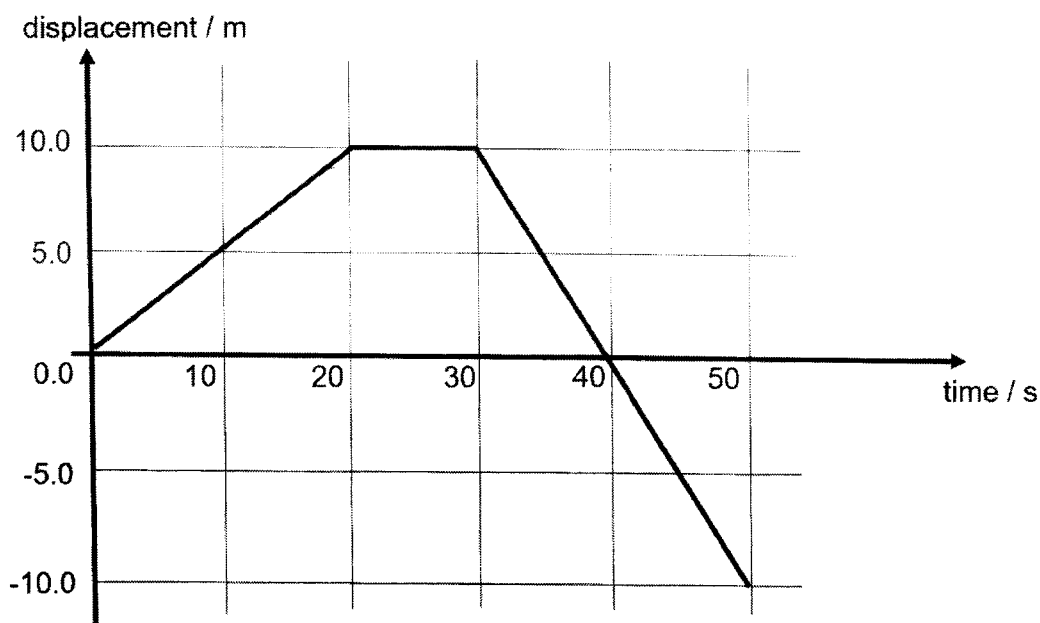

What is the total distance travelled by the car in 50 s?

- A - 10 m  
 B 0 m  
 C 30 m  
 D 300 m
- 5 A block of mass 2 kg is pulled by a constant force of 10 N. It moves with an acceleration of  $3.0 \text{ m/s}^2$  on a horizontal ground as shown below. At a certain instant during its motion, the 10 N force is removed.

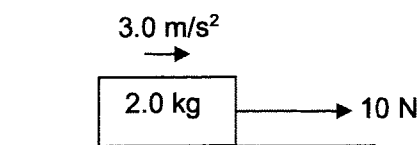

What is the motion of the block immediately after the 10 N force is removed?

- A accelerates in the opposite direction  
 B continue to move forward with a constant velocity  
 C continue to move forward with a deceleration  
 D immediately comes to a stop

- 6 The diagram below shows a ball being released on a frictionless track from rest at point L.

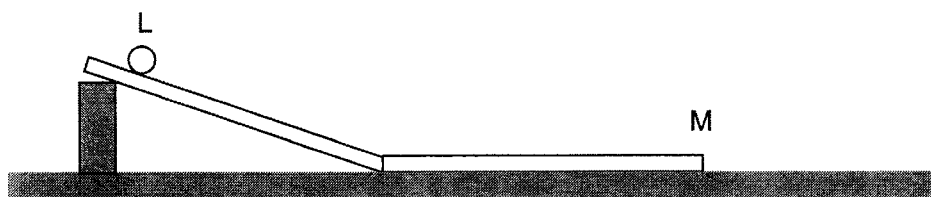

Assuming negligible air resistance, which graph correctly shows how the speed of the ball varies with time from L to M?

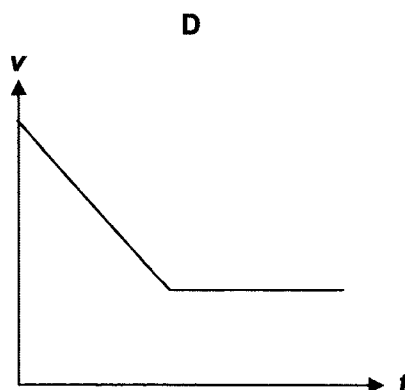
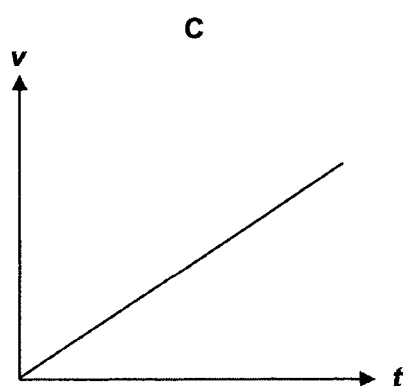
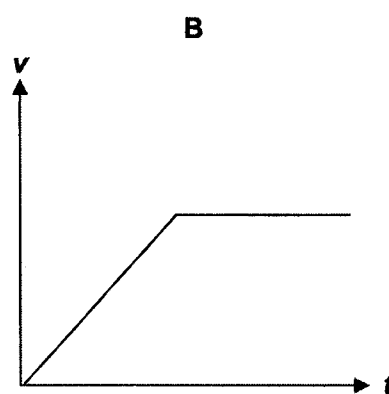
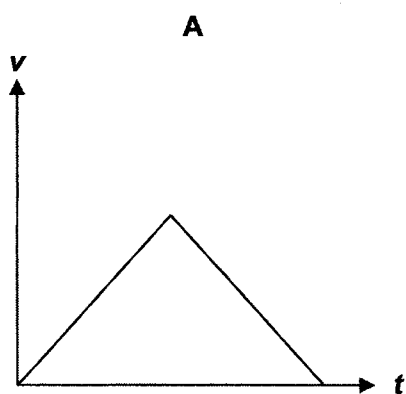

- 7 A metal cube has a mass of 15 g. Each side measures 4.0 cm. The density of the metal is  $3000 \text{ kg / m}^3$ .

There is empty space in the middle of the cube.

Which is the volume of the empty space?

- A  $5.0 \text{ cm}^3$     B  $11 \text{ cm}^3$     C  $19 \text{ cm}^3$     D  $59 \text{ cm}^3$
- 8 The diagram below shows a hinged uniform rod that is held horizontal by a wire stay.

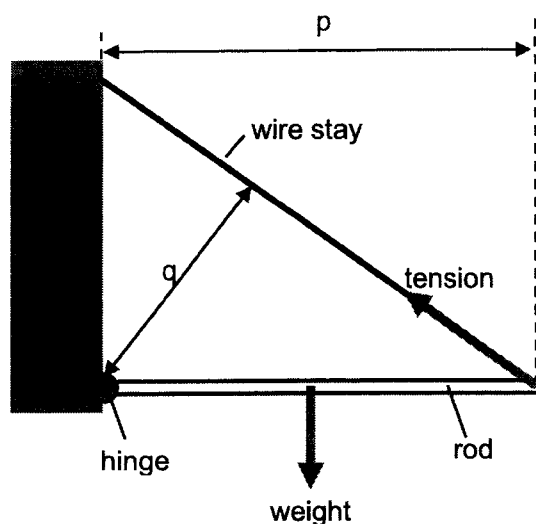

Which expression to calculate the tension in the wire stay is correct?

- A tension = weight  $\times (p / 2) + p$   
 B tension = weight  $\times (p / 2) + q$   
 C tension = weight  $\div (p / 2) \times q$   
 D tension = weight  $\div (p / 2) \div q$
- 9 A non-uniform object is placed on an inclined plane. The object is just about to topple.

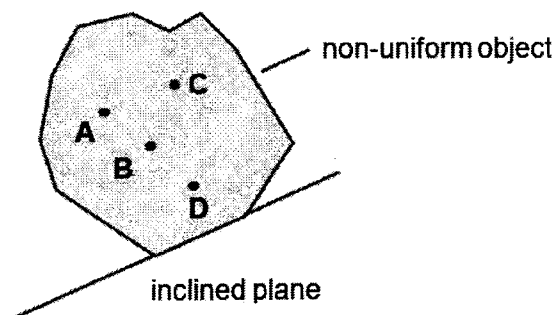

Which position is the centre of gravity?

- 10 Two vessels are joined together with a tube and filled with water. Both vessels are open at the top.

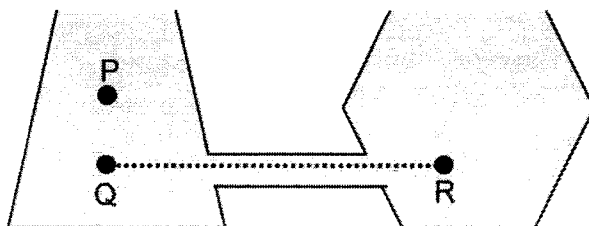

How does the water pressure at point Q compare to the water pressures at P and R?

	pressure at P	pressure at R
A	lower than at Q	greater than Q
B	same as at Q	greater than Q
C	lower than at Q	same as at Q
D	same as at Q	same as at Q

- 11 The diagram below shows a simple hydraulic jack.

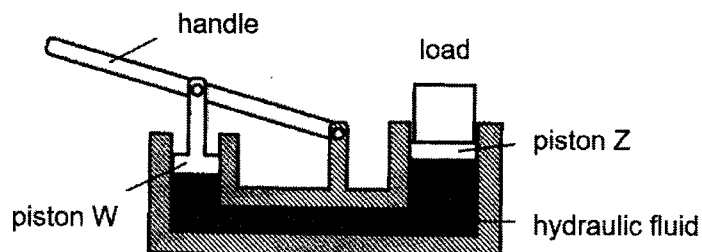

Which modifications will enable heavier loads to be lifted?

	diameter of W	diameter of Z
A	doubled	halved
B	doubled	remains the same
C	halved	doubled
D	remains the same	halved

- 12 A truck is travelling at a steady speed along an expressway.

The forward force is 4000 N and the power produced is 10 000 W.

How far does the truck travel in one minute?

- A 2.5 m      B 24 m      C 150 m      D 66 km

- 13 A manometer is filled with a liquid of density  $880 \text{ kg/ m}^3$ .

The gravitational field strength  $g$  is  $10 \text{ N/ kg}$ .

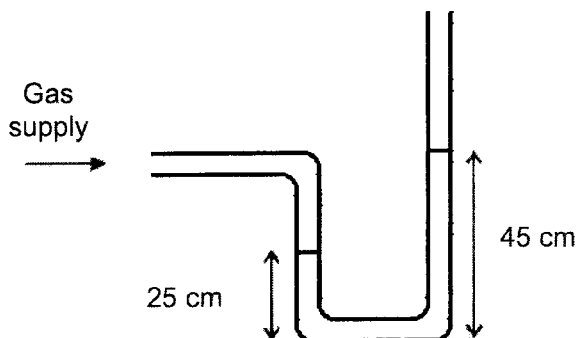

What is the excess pressure of the gas supply compared to atmospheric pressure?

- A 1760 Pa  
 B 2200 Pa  
 C 3960 Pa  
 D 17 600 Pa
- 14 Two balls of equal mass are dropped down a frictionless chute from the same height as shown below. As the balls emerge, ball A travels perpendicular to the ground and ball B travels parallel to the ground. Ignore energy losses to the surroundings.

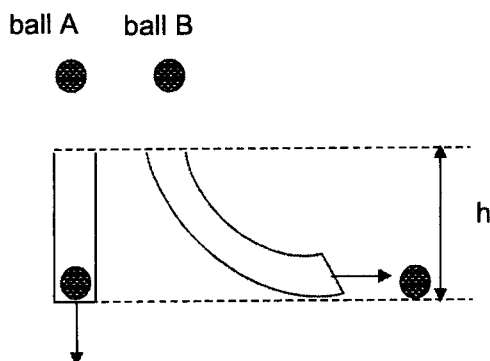

Which of the statements on the energy of the two balls as they emerge from the chutes is correct?

- A Kinetic energy of ball A is equal to ball B.  
 B Kinetic energy of ball A is lower than ball B.  
 C Gravitational energy of ball A is at its maximum and equal to ball B.  
 D Gravitational energy of ball A is lower than ball B.

- 15 The input power to a motor is 300 W. In 20 s, it lifts a load of 400 N through a height of 6.0 m.

What is the efficiency of the motor?

- A 12 %
- B 25 %
- C 40 %
- D 75 %

- 16 In the Brownian experiment, smoke particles are viewed under a microscope.

Which row describes and explains Brownian motion?

	description	explanation
A	random	air molecules cannot be seen under a microscope and bombard the smoke particles
B	random	air molecules can be seen under a microscope and bombard the smoke particles
C	random	smoke particles can be seen under a microscope and bombard the air molecules.
D	vibrate	both smoke particles and air molecules can be seen under a microscope and smoke particles bombard the air molecules

- 17 A fixed mass of gas is kept at constant temperature. When the volume of the gas decreases, the pressure increases.

Why is this?

- A The molecules are closer together and they collide more frequently.
- B The molecules are closer together and they move faster.
- C The molecules move more quickly and they collide more frequently.
- D The molecules move more quickly and they hit each other harder.

- 18 Physical properties of materials are used in the measurement of temperature.

Which physical property is **not** suitable for this purpose?

- A expansion of a metal
- B mass of a liquid
- C resistance of a metal
- D volume of a liquid



- 19 The diagram shows a section through a particular type of building board.

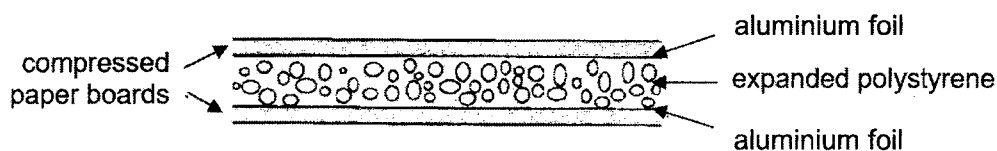

Which best explains why such boards provide good heat insulation?

	aluminium foil	expanded polystyrene	compressed paper boards
<b>A</b>	is a good conductor	is a good reflector	has high thermal conductivity
<b>B</b>	is a good conductor	is a poor reflector	has high thermal conductivity
<b>C</b>	is a good reflector	is a good conductor	has low thermal conductivity
<b>D</b>	is a good reflector	is a poor conductor	has low thermal conductivity

- 20 The cooling unit of an air conditioner is always placed at the top of rooms. The air conditioner takes in warm air and gives out cold air.

Which statements explains this?

- A** A cool air molecule is denser than a warm air molecule and sinks.
- B** A cool air molecule is less dense than a warm air molecule and rises.
- C** The cool air is denser than the warm air and sinks.
- D** The cool air is less dense than the warm air and sinks.

- 21 Four metal cans are identical except for the colour and texture of their outer surface. 100 cm<sup>3</sup> of water at 70 °C is poured into each can.

In which metal can will the water cool most rapidly?

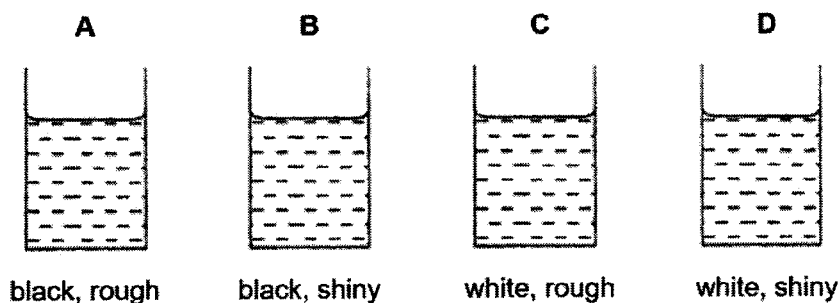

- 22 An iron block of mass 10 kg is kept at room temperature.

If the mass of the iron block is reduced to half which statement about the specific heat capacity and heat capacity is correct?

	specific heat capacity	heat capacity
A	lesser	lesser
B	same	lesser
C	lesser	same
D	same	same

- 23 1.5 kg of liquid X is heated up by an immersion heater of power 100 W for 7.5 min in a vessel of heat capacity 20 J/°C. The temperature of X and the vessel is raised from 20 °C to 30 °C and 600 J of energy is lost to the surroundings.

What is the specific heat capacity of X?

- A 2950 J/kg °C  
 B 3000 J/kg °C  
 C 4430 J/kg °C  
 D 5900 J/kg °C
- 24 The boat oscillates vertically as the water wave passes.

The graph shows how the displacement of the boat from its equilibrium position varies with time.

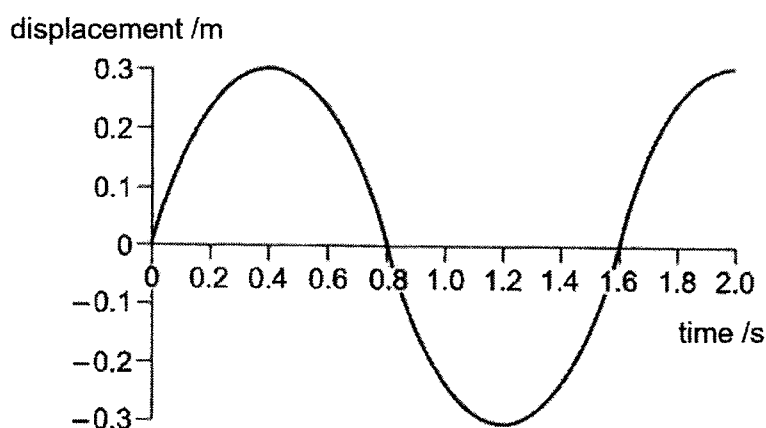

What characteristics of the wave can be deduced from the graph?

- A Its amplitude is 0.3 m and its speed is 0.75 m/s.  
 B Its amplitude is 0.3 m and its period is 1.6 s.  
 C Its wavelength is 1.6 m and its speed is 0.75 m/s.  
 D Its wavelength is 1.6 m and its period is 1.6 s.

25 A person stands at point X as shown in the diagram below.

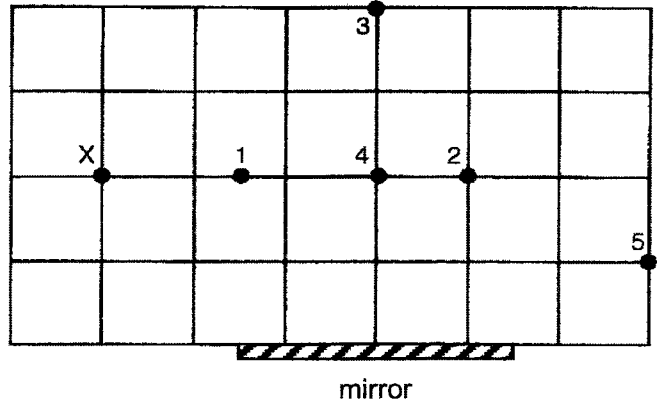

Which of the pins (1, 2, 3, 4, 5) will the person be able to see in the mirror?

- A pins 1 and 3
- B pins 2 and 4
- C pins 2, 3 and 5
- D pins 2, 4 and 5

26 A ray of light travels from vacuum into glass.

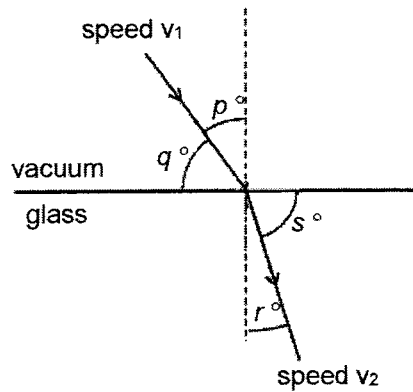

Which quantity gives a constant value as the angle of incidence of the ray changes?

- |  |  |
|--|--|
| <p><b>A</b> <math>\frac{\sin(p^\circ)}{\sin(s^\circ)}</math></p> | <p><b>B</b> <math>\frac{\sin(p^\circ)}{\sin(r^\circ)}</math></p> |
| <p><b>C</b> <math>\frac{\sin(q^\circ)}{\sin(s^\circ)}</math></p> | <p><b>D</b> <math>\frac{\sin(q^\circ)}{\sin(r^\circ)}</math></p> |

- 27 In the diagram, a convex lens forms an image I of an object O. The diagram is not drawn to scale.

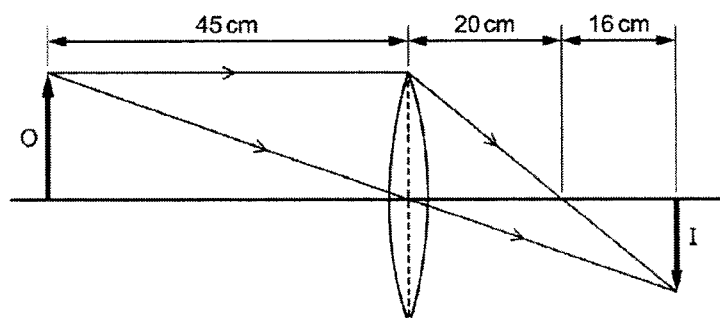

What happens as the object is moved towards the focal point?

- A The image moves further than 36 cm from the lens and decreases in size.  
 B The image moves further than 36 cm from the lens and increases in size.  
 C The image moves towards the lens and decreases in size.  
 D The image moves towards the lens and increases in size.
- 28 Which row does **not** show a correct application of the stated electromagnetic wave?

	electromagnetic wave	application
A	x-rays	detection of bone fractures
B	radio waves	satellite television
C	gamma-rays	medical treatment
D	ultraviolet radiation	sterilisation

- 29 The diagram shows the resulting sound wave produced by a speaker.

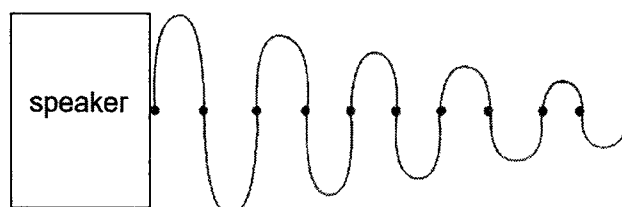

How does the sound produced by the speaker vary as time passes?

- A The pitch of the sound becomes higher.  
 B The pitch of the sound becomes lower.  
 C The sound becomes less loud.  
 D The sound becomes louder.

30 What **always** experiences a force when placed in an electric field?

- A a solenoid
- B a magnet
- C a piece of wood
- D an electric charge

31 A negatively charged copper sphere rests on an insulating mat.

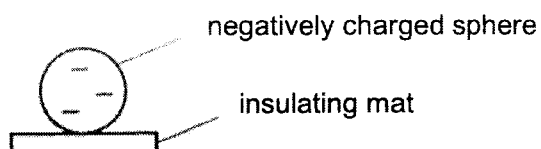

A negatively charged polythene rod is brought near to the copper sphere.

Which diagram best shows the distribution of charge on the sphere?

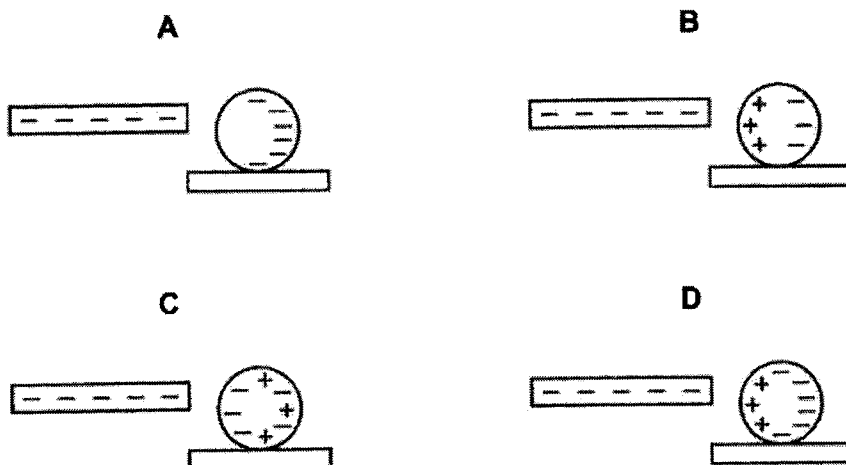

32 The voltage produced by a generator is 20 000 V. The ammeter records a current of 0.00060 A. If each electron carries a charge of  $1.6 \times 10^{-19}\text{C}$ ,

how many electrons pass through the ammeter in 2.0 s?

- A  $3.3 \times 10^7$
- B  $7.5 \times 10^{14}$
- C  $3.8 \times 10^{14}$
- D  $7.5 \times 10^{15}$

- 33 The diagrams show the voltage-current graphs for four electrical devices.

Which diagram shows the resistance increasing as the current rises?

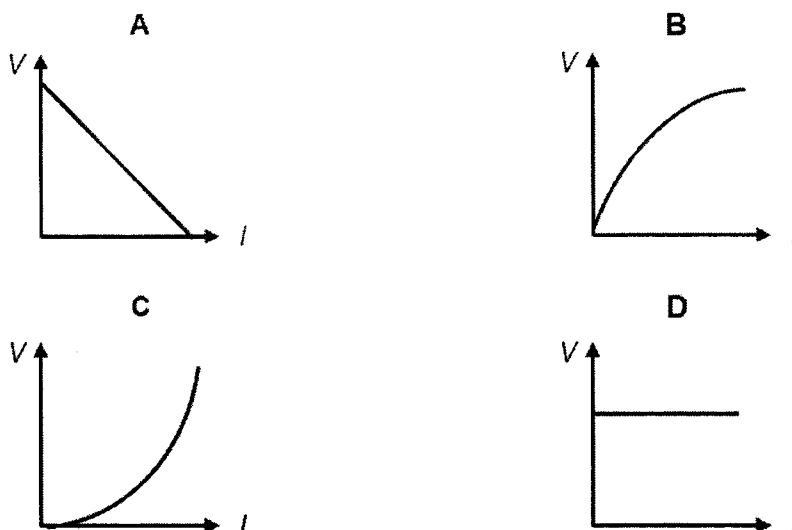

- 34 A thermistor  $T$  increases in resistance as temperature decreases and is used in a fire alarm system.

The alarm is triggered when the potential difference between  $X$  and  $Y$  is  $4.5\text{ V}$ .

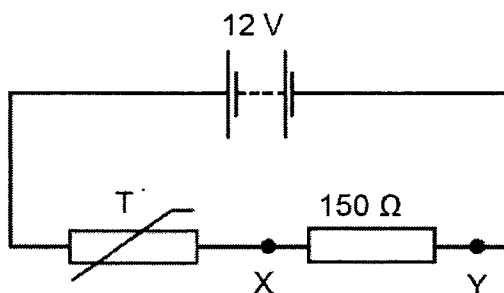

What is the resistance of  $T$  when the alarm is triggered?

- A  $90\ \Omega$
- B  $250\ \Omega$
- C  $400\ \Omega$
- D  $550\ \Omega$

- 35 The graphs show the variation of current  $I$  with potential difference  $V$  for a metal wire at constant temperature, a semiconductor diode and a filament lamp.

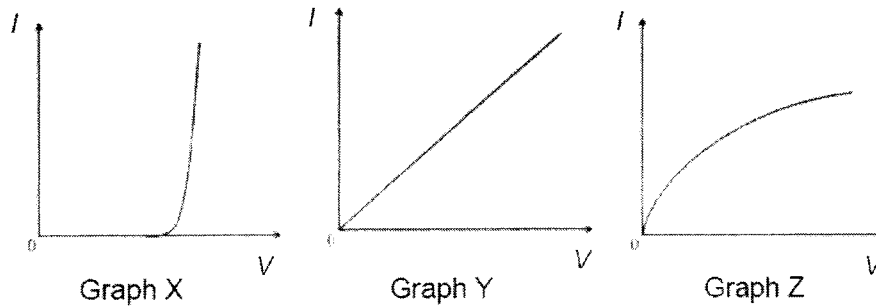

Which row correctly identifies these graphs?

	metal wire	semiconductor diode	filament lamp
<b>A</b>	X	Z	Y
<b>B</b>	Y	X	Z
<b>C</b>	Y	Z	X
<b>D</b>	Z	X	Y

- 36 The power produced in a resistor  $P$ . The voltage across the resistor is then doubled.

What is the new power produced in the resistor?

- A**  $\frac{P}{2}$
- B**  $P$
- C**  $2P$
- D**  $4P$

- 37 Each of the diagrams below is a cross-section through two parallel current-carrying conductors.

Which diagram correctly shows the magnetic field pattern formed by the currents in the two conductors?

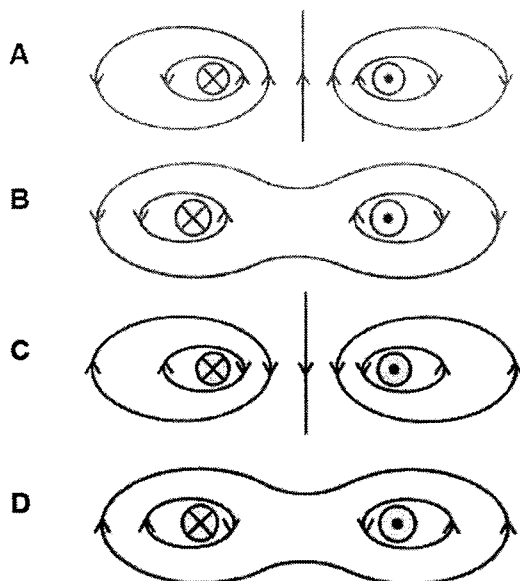

- 38 A metal rod **AB** is placed on two smooth horizontal metal rails on the bench.

The rail and the rod are subjected to an external magnetic field. The top view of the setup is shown below.

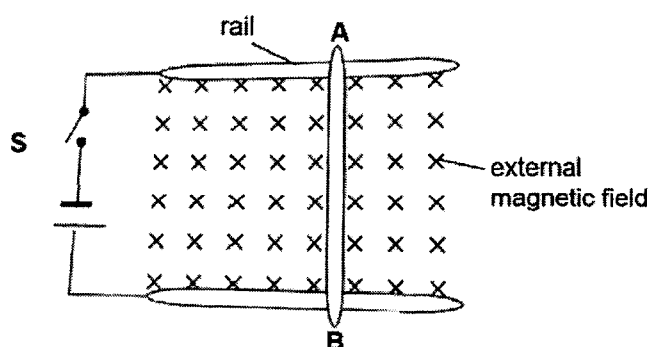

When switch **S** is closed, in which direction will rod **AB** move?

- A into the page
- B out the page
- C to the right of the page
- D to the left of the page



- 39 The diagram shows a fixed solenoid near a coil hung free to move. The material within the coil and solenoid is a paper roll.

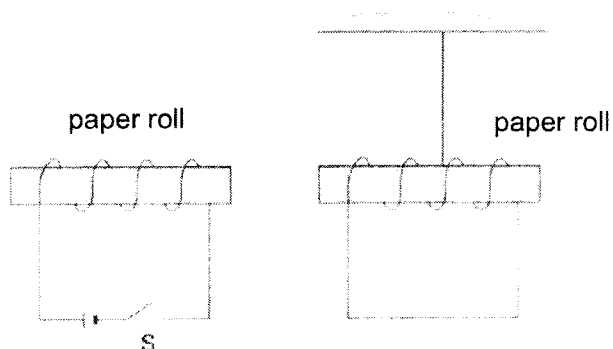

What happens to the coil when switch S is closed?

- A attracted to the solenoid and then returns to rest
  - B repelled by the solenoid and then returns to rest
  - C remains at rest
  - D swings back and forth
- 40 A transformer is used with an a.c. supply to power a 12 V lamp at its correct rating. The transformer has an efficiency of 100%.

What supply voltage, number of turns on the primary coil and number of turns on the secondary coil are suitable?

	supply voltage/ V	number of turns on primary coil	number of turns on secondary coil
A	24	200	1000
B	24	200	10 000
C	240	2000	10
D	240	2000	100

**End of Paper**

Name: ..... Index no: ..... Class: .....



**Bukit Batok Secondary School**  
**GCE 'O' LEVEL PRELIMINARY EXAMINATIONS 2022**  
**SECONDARY FOUR EXPRESS**

**PHYSICS**  
 Paper 2 Theory

6091 / 02

23 Aug 2022

1105 – 1250 h

**1 hour 45 minutes**

Candidates answer on the Question Paper

No Additional Materials are required.

**READ THESE INSTRUCTIONS FIRST**

Write your name, class, and class register number on all the work you hand in.

Write in dark blue or black ink.

You may use an HB pencil for any diagrams or graphs.

Do not use staples, paper clips, glue or correction fluid.

**Section A**Answer **all** questions in the space provided.**Section B**Answer **all** questions in the space provided. Question 12 has a choice of parts to answer.Candidates are reminded that **all** quantitative answers should include appropriate units.

The use of an approved scientific calculator is expected, where appropriate.

Candidates are advised to show all their working in a clear and orderly manner, as more marks are awarded for sound use of Physics than for correct answers.

At the end of examination, fasten all your work securely together.

The number of marks is given in brackets [ ] at the end of each question or part question.

FOR EXAMINER'S USE	
<b>Section A</b>	
<b>Section B</b>	
<b>TOTAL</b>	

---

 This Question Paper consists of **22** printed pages.

**Section A**

Answer **all** the questions in this section.

- 1 A motor-boat travels due north at a steady speed of 3.0 m/s through calm water in which there is no current.

The boat then enters an area of water in which a steady current flows at 2.0 m/s in a south-west direction as shown in Fig. 1.1. Both the engine power and the course setting remain unchanged.

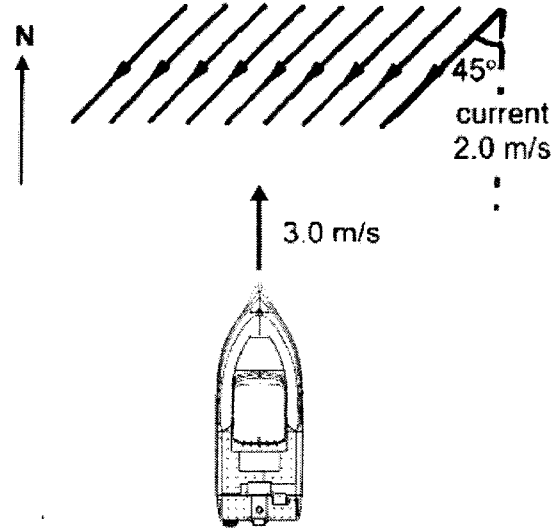

**Fig. 1.1**

In the space below, draw a vector diagram to determine

- the magnitude of the resultant velocity of the boat,
- the angle between due north and the resultant velocity of the boat.

State the scale that you use for your vector diagram.

scale: .....

magnitude = .....

angle = ..... [4]

*Applying past knowledge to new situations*

2

- 2 Fig. 2.1 shows an athlete throwing a discus. The mass of the discus is 1.0 kg. The discus is held at arm's length. She turns in a circle before releasing the discus. In completing one circle the discus travels 6.0 m in 1.5 s. At the instant the discus is released, it has a speed of 54 km/h.

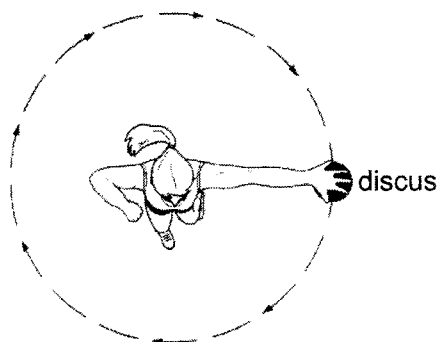

Fig. 2.1

- (a) (i) Calculate the average speed of the discus before it is released. Give your answer to an appropriate number of significant figures.

average speed = ..... [2]

- (ii) It is known that speed is a scalar quantity and velocity is a vector quantity. Explain why the average speed and average velocity of the discus is different.

.....  
 ..... [1]

- (b) Calculate the kinetic energy of the discus when it is released. Give your answer to an appropriate number of significant figures.

kinetic energy = ..... [3]

- 3 Fig. 3.1 shows the horizontal forces acting on a car when it is moving on level road. The sum of air resistance and friction is known as the total resistive force.

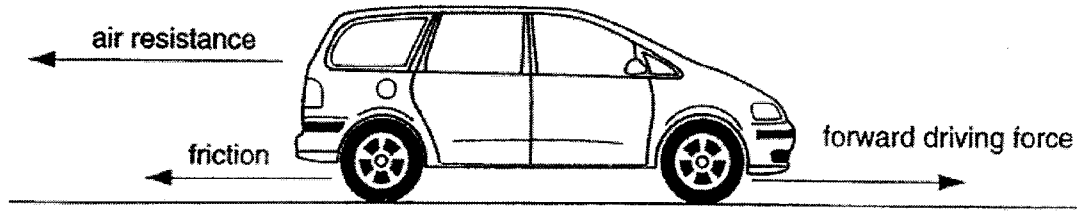

Fig. 3.1

A graph of total resistive force against time  $t$  is shown in Fig. 3.2.

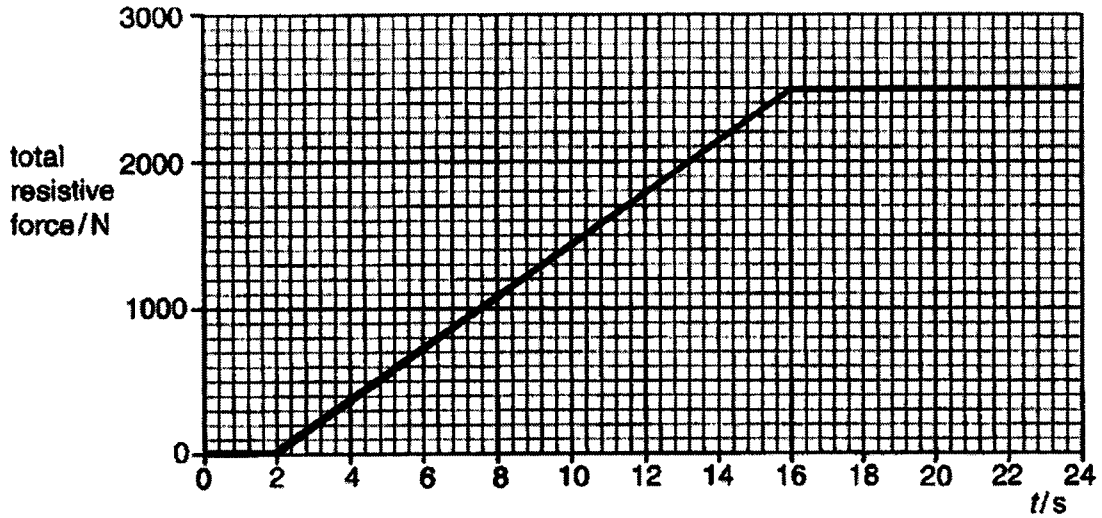

Fig. 3.2

The car is at rest at  $t = 0$  s.  
 The forward driving force acting on the car is zero until  $t = 2.0$  s.  
 From  $t = 2.0$  s to  $t = 24$  s, the driving force has a constant value of 2500 N.  
 The car has a mass of 850 kg.

- (a) (i) During which two time intervals are the forces on the car balanced?  
 ..... [1]
- (ii) Describe the motion of the car during these two time intervals.  
 .....  
 .....  
 ..... [2]

Question continues on next page...

- (b) (i) Calculate the acceleration of the car at  $t = 2.0$  s.

acceleration = ..... [2]

- (ii) Calculate the value of time  $t$  when the acceleration of the car is  $2.0 \text{ m/s}^2$ .

$t = \dots\dots\dots$  [3]

4 Fig. 4.1 shows a sack truck supporting a box.

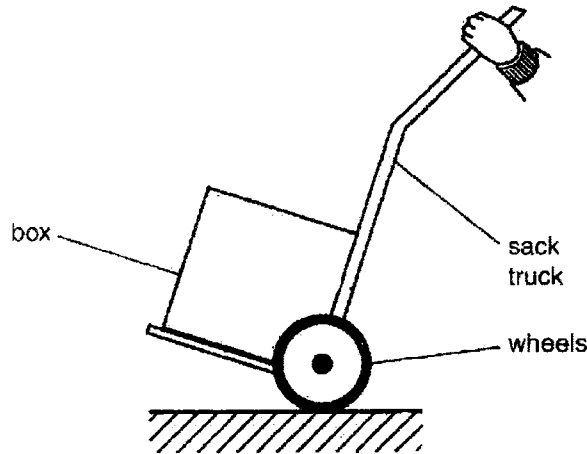

Fig. 4.1

Three of the forces acting on the truck are

- the weight **W** of the box,
- the effort force **E** provided by the hands,
- the force **F** between the ground and the wheels.

(a) On Fig. 4.1, mark and label these three forces. Show clearly where each force acts and the direction of each force. [3]

(b) By applying the principle of moments, explain how the design of the truck makes it easier to lift the box.

.....

.....

..... [2]

- 5 Fig. 5.1 shows a syringe that contains a gas at the same pressure as the air outside. The piston moves freely along the cylinder without any friction. No gas escapes. The sealed end has a smaller cross-sectional area than the piston.

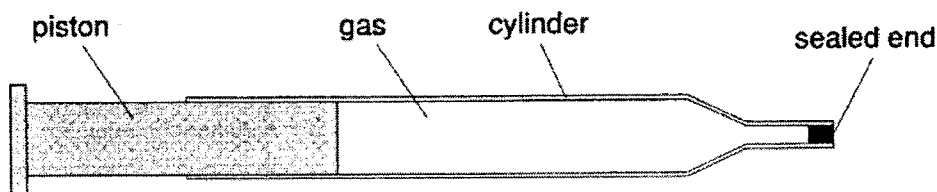

Fig. 5.1

- (a) Use ideas about molecules, explain why

- (i) the gas exerts a pressure on the cylinder.

.....  
 .....  
 .....

[2]

- (ii) the gas exerts the same pressure on the piston as it does on the sealed end.

.....  
 .....

[1]

- (b) As the syringe is heated from 20 °C to 100 °C, the piston moves outwards to the left. It stops moving when the temperature is steady. State how the value of each of the following quantities compares at 100 °C, after the piston stops, with its value at 20 °C.

For each quantity you should only write *greater*, *the same* or *less*.

(i)	average distance between gas molecules		[1]
(ii)	pressure of the gas after the piston stops		[1]
(iii)	average speed of the gas molecules		[1]
(iv)	frequency of collision between gas molecules and cylinder		[1]



- 6 The displacement-time graph of a particle X of a transverse wave is as shown in Fig. 6.1.

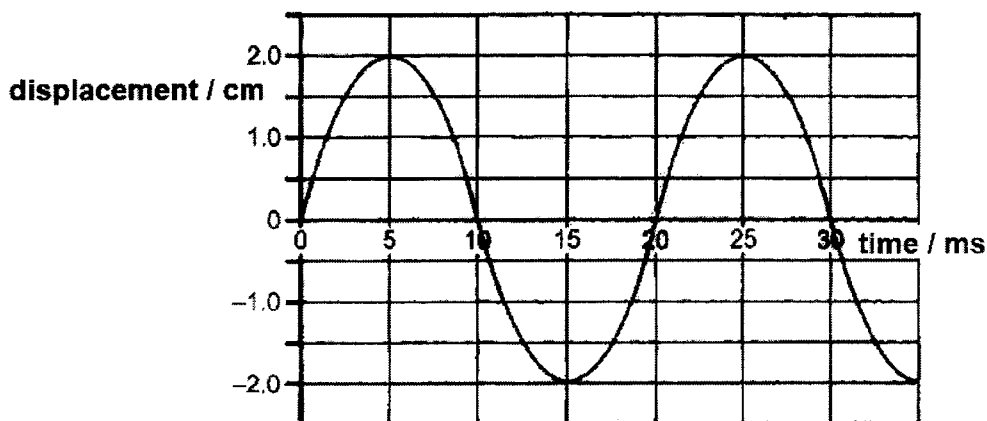

Fig. 6.1

Fig. 6.2 shows some wavefronts of the same wave.

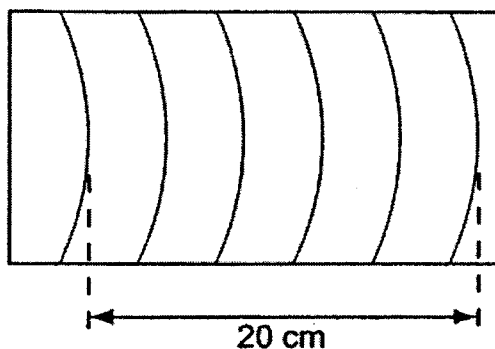

Fig. 6.2

- (a) Based on Fig. 6.1, describe the movement of particle X for one complete cycle, starting from time  $t = 0$ .

.....  
 .....  
 ..... [3]

- (b) State what is meant by the wavefront of a wave.

.....  
 ..... [1]

**Question continues on next page...**

- (c) Use the wave equation to calculate the speed of propagation of the wave.  
Express your answer in SI unit.

speed = ..... [2]

- 7 Fig. 7.1 shows words seen through a lens. Fig. 7.2 shows the same words without the lens.

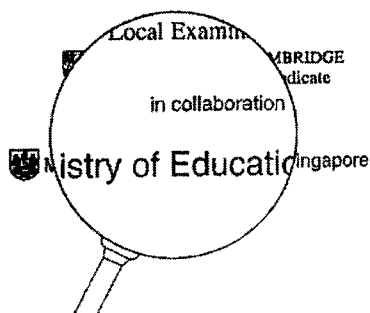

Fig. 7.1

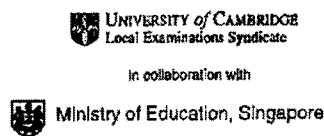

Fig. 7.2

- (a) Based on Fig. 7.1, state **two** properties of the image formed by the lens.  
 ..... [1]
- (b) On Fig. 7.3, draw a ray diagram to show how the image in Fig. 7.1 was formed by the lens. Mark clearly the focal length ( $f$ ) of the lens and the image formed.

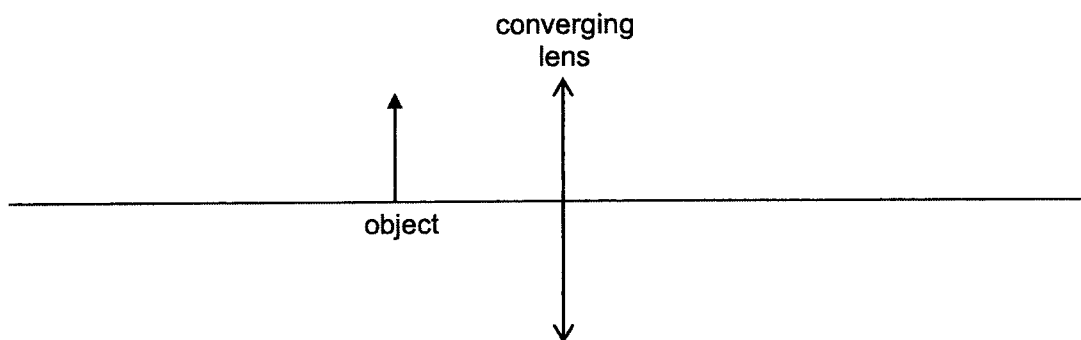

Fig. 7.3 [4]

- (c) The lens is then replaced by another lens of smaller diameter but of the same focal length.  
 Describe any change to the image formed by the smaller lens.  
 ..... [1]

*Applying past knowledge to new situations*

10

- 8 Fig. 8.1 shows an electric circuit containing two resistors.

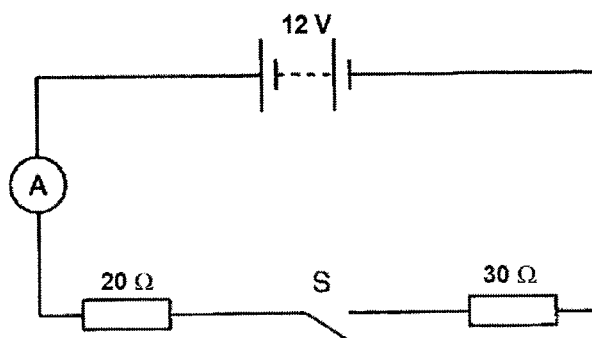

Fig. 8.1

- (a) When switch S is open, the ammeter reading is zero.  
State the value of the potential difference (p.d.) across switch S.

p.d. = ..... [1]

- (b) Switch S is now closed.

- (i) Calculate the current through the  $20\ \Omega$  resistor.

current = ..... [2]

- (ii) Calculate the potential difference (p.d.) across the  $30\ \Omega$  resistor.

p.d. = ..... [1]

- (iii) State the value of the potential difference (p.d.) across switch S.

p.d. = ..... [1]

- 9 A straight wire AB is connected to a centre-zero sensitive ammeter and move vertically downwards, towards a pair of strong permanent magnets as shown in Fig. 9.1.  
9.1.  
In doing so, the needle of the centre-zero sensitive ammeter deflects momentarily to the right (deflects to the right briefly and returns to zero).

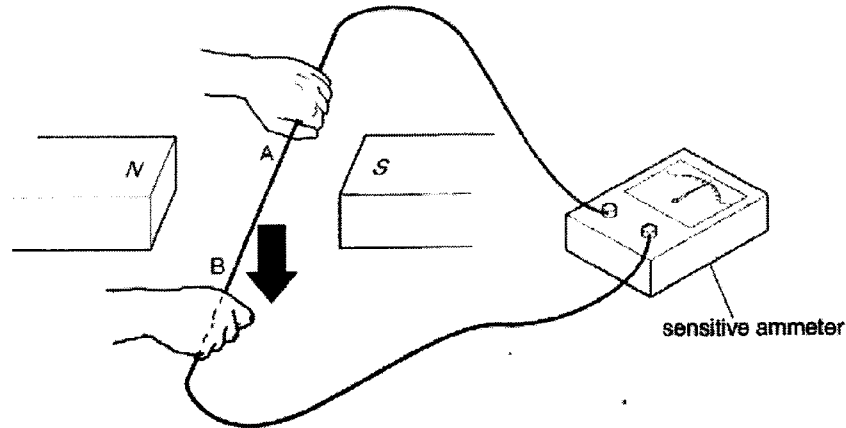

**Fig. 9.1**

- (a) Explain what causes this momentary deflection.

.....  
 .....  
 .....

[2]

- (b) State what happens to the needle of the sensitive ammeter when wire AB is moved vertically upwards at a greater speed.

.....

[1]

**Section B**

Answer **all** the questions in this section.

Answer only one of the two alternative questions in **Question 12**.

**10** Some information is given below for an electric car for use in a town.

	with a load of 80 kg	with a load of 160 kg
maximum speed	10.9 m/s	10.9 m/s
initial acceleration	2.00 m/s <sup>2</sup>	1.82 m/s <sup>2</sup>

mass of car without any load	900 kg
furthest distance travelled by car at maximum speed without recharging	49 km
average power produced by battery at maximum speed	4.24 kW
e.m.f. of battery	48 V
maximum charging current	95 A

**(a) (i)** When the load in the car doubles from 80 kg to 160 kg, the initial acceleration of the car decreases.  
Explain what caused this decrease in acceleration to occur.

.....

.....

.....

.....

.....

[2]

**(ii)** Explain, in terms of the forces acting on the car, why the car has a maximum speed.

.....

.....

.....

.....

.....

.....

.....

[3]

**Question continues on next page...**

(b) The car travels the furthest distance at the maximum speed without recharging.

Calculate

(i) the time taken,

time = ..... [1]

(ii) the energy provided by the battery,

energy = ..... [1]

(iii) the minimum time taken to fully recharge the battery.

time = ..... [2]

(iv) State **one** assumption that you made in calculating (b)(iii).

.....  
.....  
..... [1]

- 11 (a) Fig. 11.1 shows a small plotting compass placed above a copper wire. When there is no current in the wire, the plotting compass points towards the North.
- Fig. 11.2 shows the same set-up as shown in Fig. 11.1 but a large direct current now flows through the wire.
- The direction of the direct current is as shown in Fig. 11.2.

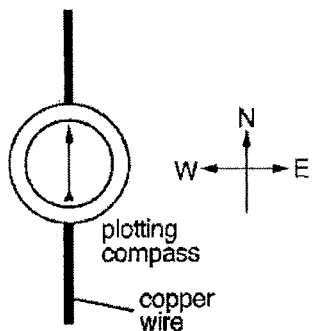

Fig. 11.1

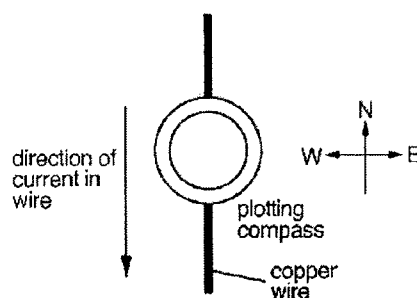

Fig. 11.2

- (i) State what happens to the needle of the plotting compass.

..... [1]

- (ii) An alternating current of frequency 50 Hz now flows through the wire. State and explain what is observed in the needle of the plotting compass.

.....

.....

..... [2]

- (b) Fig. 11.3 shows the diagram of a simple d. c. motor.

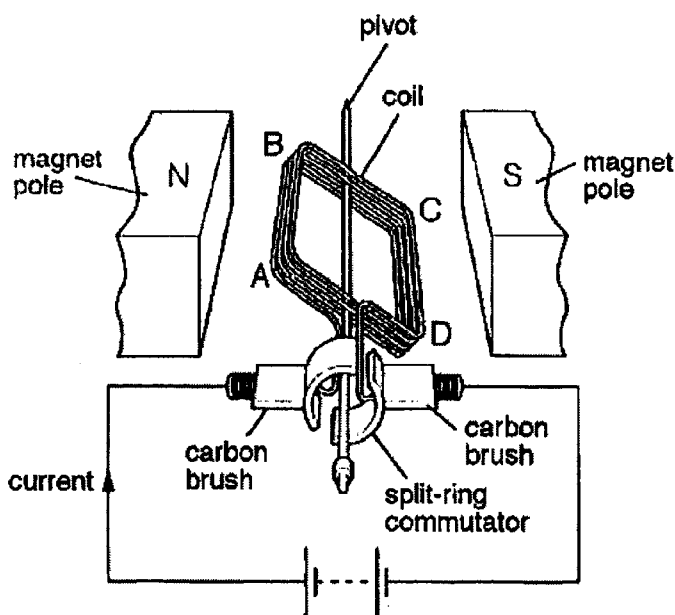

Fig. 11.3



The gap between the two halves of the split-ring commutator is so wide that a carbon brush can only touch one half of the split-ring at any time. This protects the circuit. It also means that sometimes the motor will not start when switched on.

The coil is rotated by vertical forces that act downwards on side AB and upwards on side CD. The current causes a constant force of 3.0 N on each side. The moment created by these forces varies as the coil turns. The moment is zero when the coil is vertical.

The distances AD and BC are both 0.065 m.

(i) Explain what would happen if the carbon brushes touch both halves of the split-ring at the same time.  
.....  
..... [1]

(ii) Suggest a reason why sometimes the motor will not start when switched on, even if there is no friction.  
.....  
..... [1]

(iii) Define the moment of a force.  
.....  
..... [1]

(iv) Calculate the value of the maximum moment created in the coil.  
  
maximum moment = ..... [1]

(v) Explain why the moment is zero when the coil is vertical.  
.....  
..... [1]

**Question continues on next page...**

- (vi) In the axes below, sketch a graph to suggest how the moment acting on the coil varies with time as the coil rotates from a horizontal position at constant speed. On the horizontal axis, mark clearly the time (T) taken for one revolution of the coil.

[2]

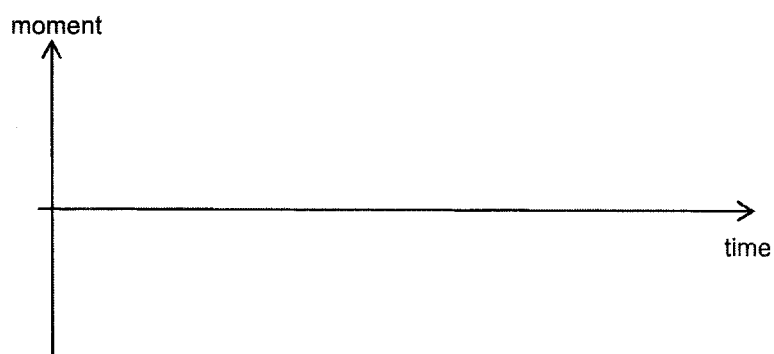

12 EITHER

(a) The boiling point of pure water at normal atmospheric pressure is 100 °C.

(i) Define what is meant by the phrase “boiling point”.

..... [1]

(ii) Describe any changes to the arrangement of water molecules during boiling.

..... [1]

(iii) Normal atmospheric pressure is conveniently taken to be 100 kPa. It is usually measured by a barometer like the one shown in Fig. 12.1. Describe how the barometer can be used to measure normal atmospheric pressure.

In your account,

- show clearly on Fig. 12.1 any measurements that are taken,
- explain how atmospheric pressure in pascal is calculated from the readings.

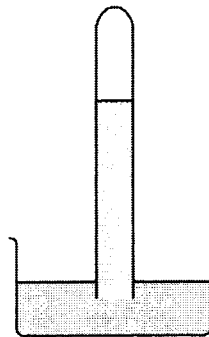

Fig. 12.1

.....  
.....  
.....  
.....  
.....  
.....  
..... [3]

- (b) A small electrical heater is used to heat water in a plastic cup, without a lid. Fig. 12.2 shows how the temperature varies for 30 minutes after the heater is switched on.

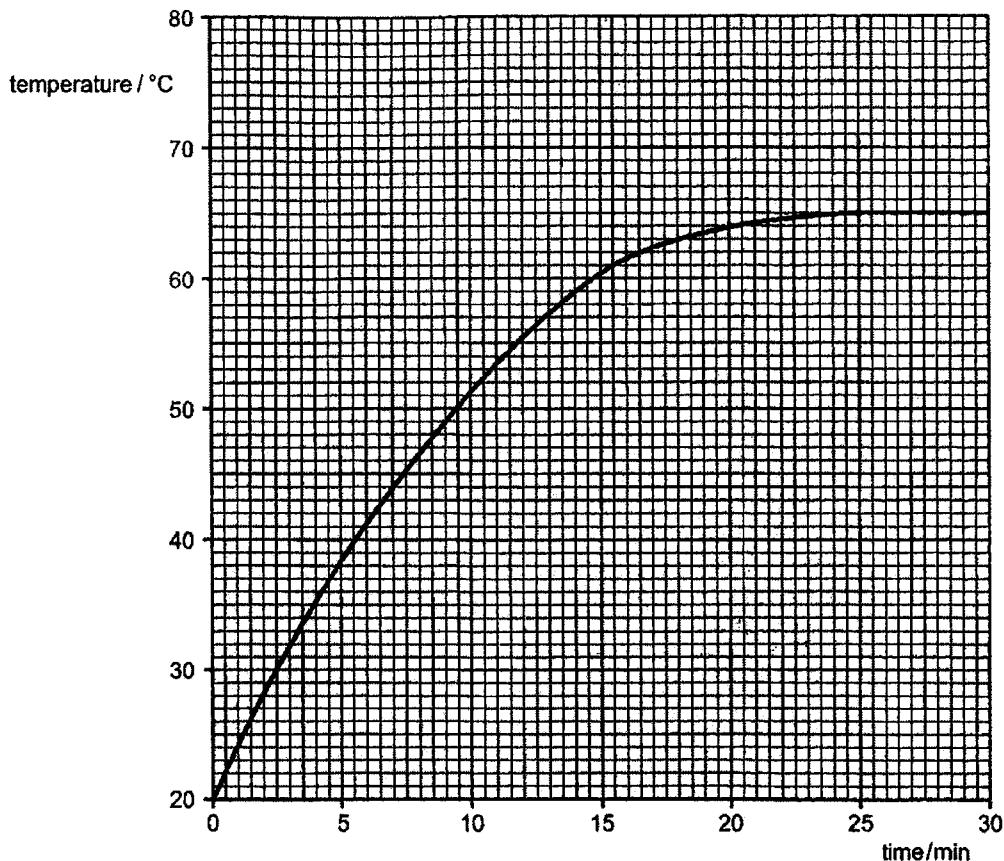

Fig. 12.2

- (i) Based on Fig. 12.2, determine the initial rate of rise in temperature, giving your answer in °C/min. Show any necessary construction lines on Fig. 12.2.

rate of rise in temperature = ..... °C/min [1]

- (ii) The heater provides a constant amount of energy per minute to the water. The mass of the water in the cup is 50 g. The specific heat capacity of the water is 4.2 J/(g°C). Using your answer to part (b)(i), calculate the energy supplied to the water per minute.

energy supplied per minute = ..... [2]

**Question continues on next page...**

(iii) After 25 minutes the temperature has stopped rising, even though heat is still supplied at the same rate to the water.

Explain why.

.....  
.....  
.....

[2]

12 OR

- (a) A 2.4 kW electric heater, which is enclosed in a metal case, is connected to a 240 V supply.

Fig. 12.3 shows the heater and the cable that connects the heater to the power supply. The cable has three wires in it: the *live*, the *neutral* and the *earth*.

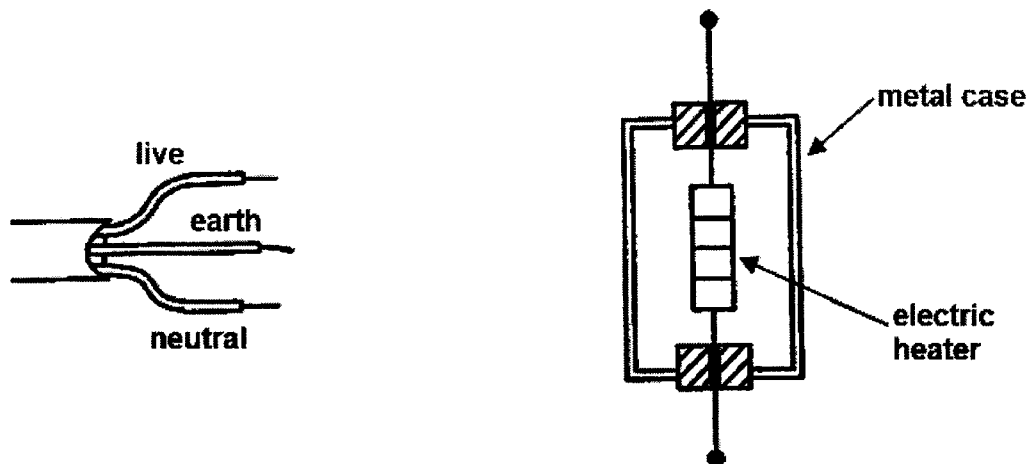

Fig. 12.3

- (i) Calculate the current flowing through the heater,

current = ..... [2]

- (ii) Calculate the resistance of the heater.

resistance = ..... [2]

- (iii) By drawing on Fig. 12.3, show how the wires in the cable should be safely connected to the electric heater. Include a switch and a fuse in your drawing. [3]

- (b) Two resistors  $R_1$  and  $R_2$  are connected first in series, as shown in Fig. 12.4, and then in parallel, as shown in Fig. 12.5.

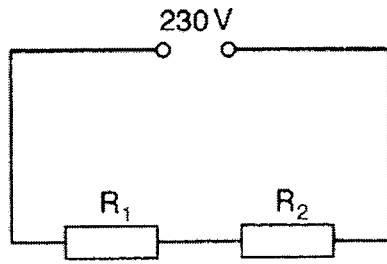

Fig. 12.4

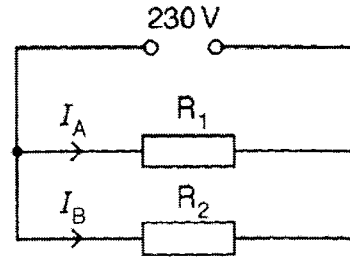

Fig. 12.5

There is no other resistance in either circuit.  
The resistance of  $R_1$  is larger than the resistance of  $R_2$ .

- (i) Without any calculation, explain why

1. in the circuit shown in Fig. 12.4, the power output of  $R_1$  is larger than the power output of  $R_2$ .

.....  
 .....  
 .....  
 .....

[1]

2. in the circuit shown in Fig. 12.5, the power output of  $R_1$  is smaller than the power output of  $R_2$ .

.....  
 .....  
 .....  
 .....

[1]

- (ii) In the circuit shown in Fig. 12.5, the resistor  $R_1$  is replaced with another resistor  $R_3$ .

The resistance of  $R_3$  is greater than the resistance of  $R_1$ .

Complete the table below to show how the replacement changes the current  $I_A$  and the current  $I_B$ .

effect on $I_A$	effect on $I_B$

[1]

\*\*\* END OF PAPER \*\*\*

Name: ..... Index no.: ..... Class: .....



## Bukit Batok Secondary School

GCE O LEVEL PRELIMINARY EXAMINATIONS 2022

SECONDARY 4 EXPRESS MARK SCHEME

PHYSICS  
Paper 1 Multiple Choice

6091/01  
30 Aug 2022  
1 Hour  
0820 – 0920 h

### Paper 1 MCQs

1	D	11	C	21	A	31	D
2	A	12	C	22	C	32	D
3	C	13	A	23	A	33	C
4	C	14	A	24	B	34	B
5	C	15	C	25	D	35	B
6	B	16	A	26	B	36	D
7	D	17	A	27	B	37	C
8	B	18	B	28	B	38	D
9	B	19	D	29	C	39	B
10	C	20	C	30	D	40	D



2022 BBSS SEC 4E PHYSICS (6091) O PRELIM EXAM  
MARK SCHEME – PAPER 2 (FOR TEACHERS ONLY)

**PAPER 2:** (W = working), (C/F = concept / formula), (A & U = answer & unit)

- **Penalize 1 mark per question** for no / wrong unit.
- **Penalize 1 mark per question** for failure to show concept / formula clearly **and explicitly** at the beginning of each mathematical working, **except Q11b(iv)**.
- Mark for s.f. in **Q2a and Q2c only**.

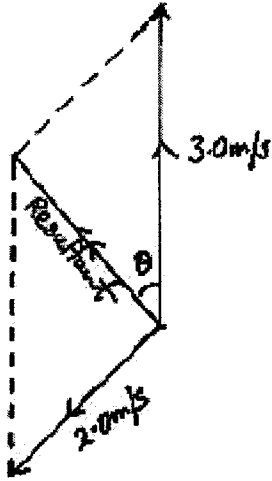
Q	Suggested Answer	Remarks
1		<p>[1]: <b>Diagram:</b> either parallelogram or triangle and all vectors must be correctly labelled and in correct direction.</p> <p>[1]: <b>Scale</b></p> <ul style="list-style-type: none"> <li>• At least "1.0 cm represents 0.50 m/s"</li> <li>• <b>Reject</b> "1.0 cm to 1.0 m/s or 2.0 m/s" – vector diagram will occupy less than half of allocated space.</li> <li>• <b>Reject</b> weird scale (e.g., 3.0 cm to 1.0 m/s)</li> </ul> <p>[1]: <b>Magnitude of resultant velocity</b> between 2.0 m/s and 2.2 m/s inclusive.</p> <p>[1]: <b>Angle between north and resultant velocity</b> between 30° and 43° inclusive.</p>
2a (i)	<p>Average speed = total distance / total time</p> $= 8.0 \text{ m} / 1.5 \text{ s}$ $= 4.0 \text{ m/s}$ <p>(Accept answer in km/h if correct)</p>	<p>[1]: W &amp; C/F</p> <p>[1]: A &amp; U</p> <p>[-1 mark if final answer not in 2 s.f.]</p>
2a (ii)	<p>Any one of the following:</p> <ul style="list-style-type: none"> <li>• Discus <b>not</b> travelling in straight line and so total displacement not the same as total distance</li> <li>• Total displacement (with respect to start point of discus) is zero.</li> </ul> <p><b>Reject</b> if student mentions "direction" without further explanation.</p> <p><b>Reject</b> if student merely writes down definitions of speed and velocity without further explanation.</p>	[1]
2b	$54 \text{ km/h} = 54\,000 \text{ m} / 3600 \text{ s} = 15 \text{ m/s}$ $\text{KE} = \frac{1}{2}mv^2 = \frac{1}{2}(1.0)(15)^2$ $= 112.5 \text{ J}$ $= 110 \text{ J (to 2 s.f.)}$	<p>[1]</p> <p>[1]: W &amp; C/F</p> <p>[1]: A &amp; U</p> <p>[-1 mark if final answer not in 2 s.f.]</p>
3a(i)	<p>t = 0 s and t = 2 s <b>and</b> t = 18 s to t = 24 s.</p> <p>[Do not penalize for no unit / wrong unit]</p>	[1] for <b>both</b>
3a(ii)	<ul style="list-style-type: none"> <li>• Between t = 0 s and t = 2 s : car at rest</li> <li>• Between t = 18 s and t = 24 s : car moves at constant velocity (accept "terminal velocity") (reject "constant speed")</li> </ul> <p>[-1 mark if student describes motion correctly but fail to state the corresponding time interval]</p>	[1]
3b(i)	<p>From the question, it is not clear if driving force is 2500 N at t = 2 s. Hence, we accept either one of the following two possible answers:</p> <p><b>Version 1 (forward driving force = 2500 N at t = 2 s)</b></p> <p>Resultant force = Forward driving force – total resistive force</p> $= 2500 - 0$ $= 2500 \text{ N}$	

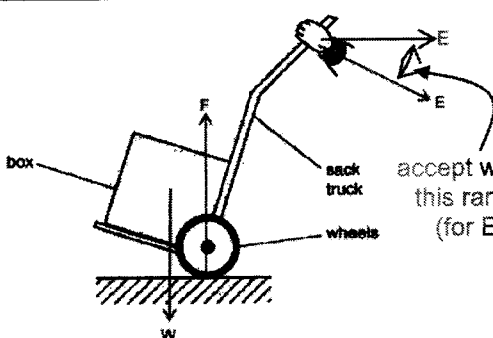
	<p>Thus, acceleration (a) = <math>F / m</math>  <math>= 2500 / 850</math>  <math>= \underline{2.94 \text{ ms}^{-2}}</math> (accept 2.9 m/s<sup>2</sup>)</p> <p><u>Version 2 (forward driving force = 0 N at t = 2 s)</u>  Resultant force = Forward driving force – total resistive force  <math>= 0 - 0</math>  <math>= 0 \text{ N}</math></p> <p>Thus, acceleration (a) = <math>F / m</math>  <math>= 0 / 850</math>  <math>= \underline{0 \text{ ms}^{-2}}</math>.</p> <p><b>NOTE:</b> penalize 1 mark if  - formula "F = ma" not written in the working.  - capital letter "A" is used to represent acceleration.</p>	[1]: W & C/F [1]: A & U
3b(ii)	<p>Resultant force = <math>ma = 850 \times 2.0 = 1700 \text{ N}</math>  But resultant force = forward driving force – total resistive force  <math>1700 = 2500 - \text{total resistive force}</math>  Hence, total resistive force = <math>2500 - 1700 = 800 \text{ N}</math>  From the graph given in the question, when total resistive force = 800 N, time  <math>t = 6.4 \text{ s}</math> (accept 6.4 s to 6.6 s)</p>	[1]  [1]: W & C/F [1]: A & U
4a	 <p>NOTE: ignore lengths of arrows</p>	<p>[1] <u>Force W</u> : arrow originates from centre of box (visual inspection suffices) and acts vertically downwards.</p> <p>[1] <u>Force E</u> : arrow originates from hand and is approximately perpendicular to distance between centre of wheel and hand (visual inspection suffices) and acts in the direction shown.</p> <p>[1] <u>Force F</u> : arrow originates from base of wheel and acts vertically upwards.</p>
4b	<ul style="list-style-type: none"> <li>Perpendicular distance between centre of wheel (pivot) and line of action of (effort) E <b>is larger than</b> perpendicular distance between centre of wheel (pivot) and line of action of W (weight of box).</li> <li>Hence, (effort) E <b>is smaller than</b> W (weight of box).</li> </ul>	[1] [1]
5a	<ul style="list-style-type: none"> <li>Gas molecules move randomly at high speeds and collide with cylinder.</li> <li>Summation of force exerted on unit area of cylinder constitutes the pressure.</li> </ul>	[1] [1]
5a (ii)	(Randomly moving) gas molecules have equal chance to collide against unit area of piston or unit area of sealed end.	[1]
5b	<ul style="list-style-type: none"> <li>(i) greater</li> <li>(ii) the same</li> <li>(iii) greater</li> <li>(iv) less</li> </ul>	[1] [1] [1] [1]
6a	<ul style="list-style-type: none"> <li>Particle X vibrates (<b>reject</b> "moves", "travels") perpendicular to direction of wave travel.</li> <li>amplitude = 2.0 cm / maximum displacement = 2.0 cm.</li> <li>Completes one cycle in 20 ms / period of 20 ms.</li> </ul>	[1] [1] [1]
6b	Imaginary line on a wave that joins all adjacent points that are in phase.	[1]
6c	<p>Frequency (<math>f</math>) = <math>1 / T = 1 / 20 \text{ ms} = 50 \text{ Hz}</math>  Wavelength (<math>\lambda</math>) = <math>20 / 5 = 4.0 \text{ cm} = 0.040 \text{ m}</math>  <math>v = f\lambda = (50)(0.040) = \underline{2.0 \text{ m/s}}</math> (allow for ecf of wrong frequency)</p>	[1] [1]: W, C/F, A & U
7a	<b>upright</b> and <b>magnified</b> ( <b>reject</b> "virtual" as it cannot be seen from Fig 7.1 and Fig. 7.2)	[1]

Applying past knowledge to new situations

2

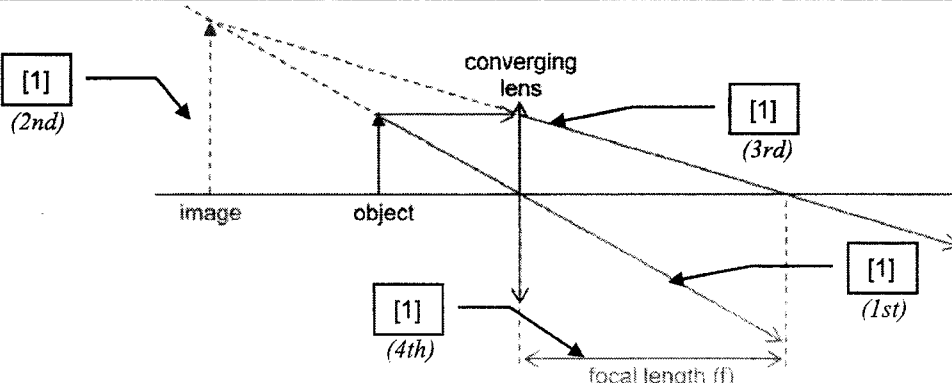
7b	 <p><b>NOTE:</b> If student draws ray diagram of a real image instead of the above, then:</p> <ul style="list-style-type: none"> <li>- Award for light ray that originates from top of object and passes through the origin straight throughout (see "1st" indicated in above diagram).</li> <li>- Award for focal length if it is correct (see "4th" indicated in above diagram).</li> </ul>	
7c	Image is <b>dimmer</b> than before ( <b>accept</b> "less bright" in lieu of "dimmer")	[1]
8a	12 V	[1]
8b (i)	$I = V / R$ $= 12 / 50$ (award 0 mark if $R = 20 \Omega$ or $30 \Omega$ ) $= \mathbf{0.24 \text{ A}}$	[1]: W & C/F [1]: A & U
8b (ii)	<b>EITHER:</b> $V = IR = (0.24)(30) = \mathbf{7.2 \text{ V}}$ (allow for ecf from 8b(i)) <b>OR (by applying p.d.p.):</b> $V = (30/50) \times 12 = \mathbf{7.2 \text{ V}}$	[1]
8b (iii)	0 V	[1]
9a	<ul style="list-style-type: none"> <li>• Rate of change of magnetic flux linked to wire AB (<b>accept</b> "conductor" in lieu of "wire AB") / change of magnetic flux linked to wire AB per second.</li> <li>• Induces an electromotive force (e.m.f.) across wire <b>and</b> induced current flows in wire.</li> </ul> <p><b>Penalize 1 mark</b> if sequence of above points is wrong (e.g., an e.m.f. is induced across wire AB and this causes a change in magnetic flux linked to wire AB per second).</p>	[1] [1]
9b	<b>Larger momentary deflection</b> to the <b>left</b> / larger deflection to the left <b>and</b> returns to zero.	[1]
10a (i)	<ul style="list-style-type: none"> <li>• <b>Resistive force</b> (friction, air resistance, etc.) acting on the car <b>increases</b>.</li> <li>• (Assume car's engine thrust force is constant) <b>Decrease in car's net force</b> (and increase in car's mass) decreases initial acceleration of the car.</li> </ul>	[1] [1]
10a (ii)	<ul style="list-style-type: none"> <li>• Constant engine thrust force and increasing resistive force decreases the net force acting on the car.</li> <li>• Eventually, engine thrust force and resistive force are equal in magnitude and opposite in direction (<b>reject</b> "engine thrust force is <b>equal</b> to resistive force")</li> <li>• Car has zero acceleration and a constant maximum speed.</li> </ul>	[1] [1] [1]
10b (i)	Time = distance / speed = $49000 \text{ m} / 10.9 \text{ ms}^{-1}$ $= 4495.412844 \text{ s}$ $= \mathbf{4500 \text{ s}}$ (to 2 s.f.) <b>Accept</b> answers in hours, hours and minutes if correct.	[1]
10b (ii)	(Change in) energy (E) = power $\times$ time $= 4240 \text{ W} \times 4495.412844 \text{ s}$ $= 19\,060\,550.4587 \text{ J}$ $= \mathbf{19 \text{ MJ}}$ (to 2 s.f.) or $\mathbf{19.1 \text{ MJ}}$ (to 3 s.f.) <b>Accept</b> answers in kilowatt-hours (kWh) if correct.	[1]

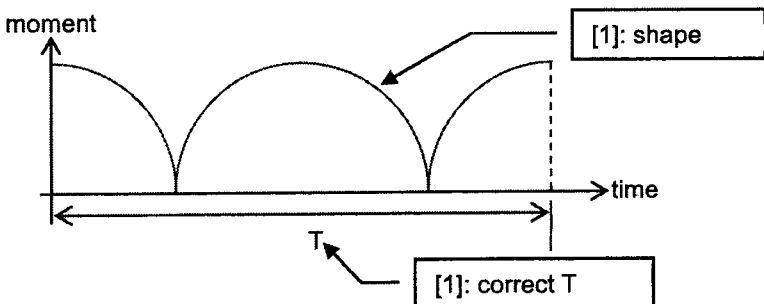
10b (iii)	(Change in) energy (E) = Pt = IVt 19 060 550.4587 = (95 A)(48 V)(t) Time t = 4179.945276 = <b>4200 s</b> (2 s.f.), <b>4190 s</b> (3 s.f.) or <b>4180 s</b> (3 s.f.) <b>Accept</b> answers in hours, hours and minutes if correct.	[1]: W & C/F [1]: A & U
10b (iv)	Any <u>one</u> of the following: <ul style="list-style-type: none"> <li>No electrical energy is converted to thermal energy / lost to the surroundings. (<b>Reject</b> "heat energy")</li> <li>Current <b>and</b> voltage stays constant during charging.</li> <li>Battery / Battery charger is 100% efficient.</li> </ul>	[1]
11a (i)	Needle points to the west / left.	[1]
11a (ii)	<ul style="list-style-type: none"> <li>Needle will remain in the same orientation as in Fig. 11.1. (Also accept "needle vibrates slightly whilst pointing north")</li> <li>(Direction of electric current reverses 50 times per second leads to) direction of magnetic field around wire reverses 50 times per second <b>and</b> inertia of needle does not allow it to alternate between pointing east and west 50 times per second.</li> </ul>	[1] [1]
11b (i)	Short circuit <b>and</b> the current will bypass / not flow through the rectangular coil.	[1]
11b (ii)	Open circuit and carbon brushes not in contact with (either half of) the split-ring (commutator).	[1]
11b (iii)	Product between the force and the perpendicular distance between the pivot and the line of action of the force.	[1]
11b (iv)	Maximum moment = $F \times d$ = (3.0)(0.065 / 2) + (3.0)(0.065 / 2) = <b>0.195 Nm</b> (accept 0.20 Nm (to 2 s.f.)) (DO NOT penalise for no formula as it has been tested in (b)(iii)).	[1]
11b (v)	Any <u>one</u> of the following: <ul style="list-style-type: none"> <li>Zero perpendicular distance between pivot and line of action of 3.0 N force.</li> <li>No current through rectangular coil due to carbon brushes not touching split ring (hence no force)</li> </ul> <b>Reject</b> if student merely writes "no force" or "no current" without further explanation.	[1]
11b (vi)	 <p><b>NOTE:</b></p> <ul style="list-style-type: none"> <li>Graph must start from maximum and not zero (Refer to diagram. If coil starts turning from horizontal position, then moments should be maximum initially).</li> <li>Graph: accept "straight lines" in lieu of curves.</li> </ul>	[1] [1]
<b>12 (EITHER)</b>		
a(i)	Temperature at which a substance changes from liquid state to gaseous state. <ul style="list-style-type: none"> <li><b>Accept:</b> temperature at which a substance changes from liquid to gas.</li> <li><b>Reject:</b> temperature at which a liquid changes to a gas (vague: any liquid? Any gas?)</li> </ul>	[1]
a (ii)	Average distance between water molecules increases / Water molecules more spaced out. <b>Reject:</b> "more disorderly arranged".	[1]

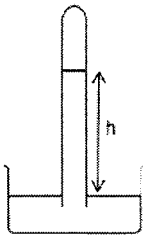
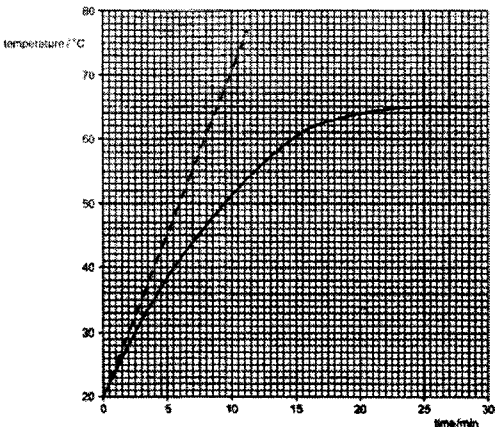
<p>a (iii)</p>		<p>[1]: height <math>h</math> shown correctly in Fig. 12.1                  [1]: Atmospheric pressure <math>P = h\rho g</math>                  [1]: height <math>h</math> to be expressed in metres <b>and</b> density of liquid (<math>\rho</math>) to be expressed in <math>\text{kg/m}^3</math> <b>and</b> <math>g</math> = gravitational field strength.</p>
<p>b(i)</p>		<p>[1]: for all the following done</p> <ul style="list-style-type: none"> <li>• Tangent (red dotted line) drawn should cut the graph at (0,20),</li> <li>• Find the gradient of this tangent.</li> <li>• Rate of rise in temperature = gradient of this gradient <b>based on student's input</b>.</li> </ul> <p><u>Sample reading:</u>  <math>(70 - 20) / (10 - 0) = 5.0 \text{ }^\circ\text{C/min}</math></p>
<p>b(ii)</p>	<p><math>Q = mc\Delta\theta</math>  <math>Q/t = mc(\Delta\theta/t)</math> (note "<math>\Delta\theta/t</math>" = value of gradient from (b)(i) above)  <math>= (50)(4.2)(5.0)</math> ← based on sample reading in (b)(i) above (allow for ecf)  <math>= 1050 \text{ J/min}</math></p>	<p>[1]: W &amp; C/F                  [1]: A &amp; U</p>
<p>b(iii)</p>	<ul style="list-style-type: none"> <li>• Rate of flow of thermal energy into water = rate of flow of thermal energy out of the water to the surroundings (water has reached thermal equilibrium with the surroundings).</li> <li>• No <b>net</b> gain of thermal energy by water (per second).</li> </ul>	<p>[1]                  [1]</p>

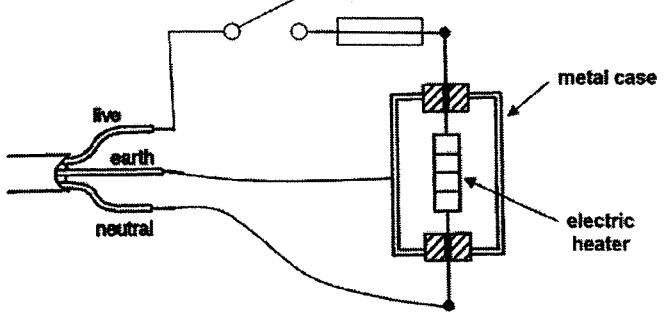
<p>12 (OR)</p>		
<p>a (i)</p>	<p><math>I = P / V = 2400 / 240</math>  <math>= 10 \text{ A}</math></p>	<p>[1]: W &amp; C/F                  [1]: A &amp; U</p>
<p>a (ii)</p>	<p><math>R = V / I = 240 / 10 = 24 \text{ } \Omega</math>, or  <math>R = V^2/P = (240)^2 / 2400 = 24 \text{ } \Omega</math></p>	<p>[1]: W &amp; C/F                  [1]: A &amp; U</p>
<p>a (iii)</p>		<p>[1]: earth wire connects to metal case.                  [1]: live, neutral wires and heater form a closed circuit.                  [1]: switch and fuse on live wire <b>and</b> correct symbols of switch and fuse.</p>
<p>b(i) 1</p>	<ul style="list-style-type: none"> <li>• Current (<math>I</math>) constant in series circuit.</li> <li>• Hence power output (<math>P</math>) is directly proportional to resistance <math>R</math> (since <math>P = I^2R</math>).</li> </ul>	<p>[1] for all</p>
<p>b(i) 2</p>	<ul style="list-style-type: none"> <li>• Voltage (<math>V</math>) constant in parallel circuit.</li> <li>• Hence power output (<math>P</math>) is inversely proportional to resistance <math>R</math> (since <math>P = V^2/R</math>).</li> </ul>	<p>[1] for all</p>
<p>b(ii)</p>	<ul style="list-style-type: none"> <li>• Current <math>I_A</math> decreases.</li> <li>• Current <math>I_B</math> remains unchanged.</li> </ul>	<p>[1] for all</p>