



**YISHUN SECONDARY SCHOOL
PRELIMINARY EXAMINATION 2022
SECONDARY 4 EXPRESS**

CANDIDATE
NAME

CLASS

--	--	--

INDEX
NUMBER

--	--

CHEMISTRY

Paper 1 Multiple Choice

6092/01

1 September 2022

1 hour

Additional Materials: Multiple Choice Answer Sheet

READ THESE INSTRUCTIONS FIRST

Write in soft pencil.

Do not use staples, paper clips, glue or correction fluid.

Write your name, class and index number on the Answer Sheet in the spaces provided.

There are **forty** questions on this paper. Answer **all** questions. For each question there are four possible answers **A, B, C** or **D**.

Choose the **one** you consider correct and record your choice in **soft pencil** on the separate Answer Sheet.

Read the instructions on the Answer Sheet very carefully.

Each correct answer will score one mark. A mark will not be deducted for a wrong answer.

Any rough working should be done in this booklet.

A copy of the Periodic Table is printed on page 20.

The use of an approved scientific calculator is expected, where appropriate.

This document consists of **19** printed pages with **1** blank page.

2

- 1 Magnesium sulfate is prepared by reacting excess magnesium carbonate with dilute sulfuric acid.



In addition to measuring cylinder, the following pieces of apparatus are available.

- 1 thermometer
- 2 evaporating dish
- 3 filter funnel
- 4 gas syringe

Which two pieces of apparatus are needed to obtain magnesium sulfate crystals?

- A** 1 and 2 **B** 1 and 4 **C** 2 and 3 **D** 3 and 4

- 2 The diagram shows apparatus used to obtain carbon monoxide.

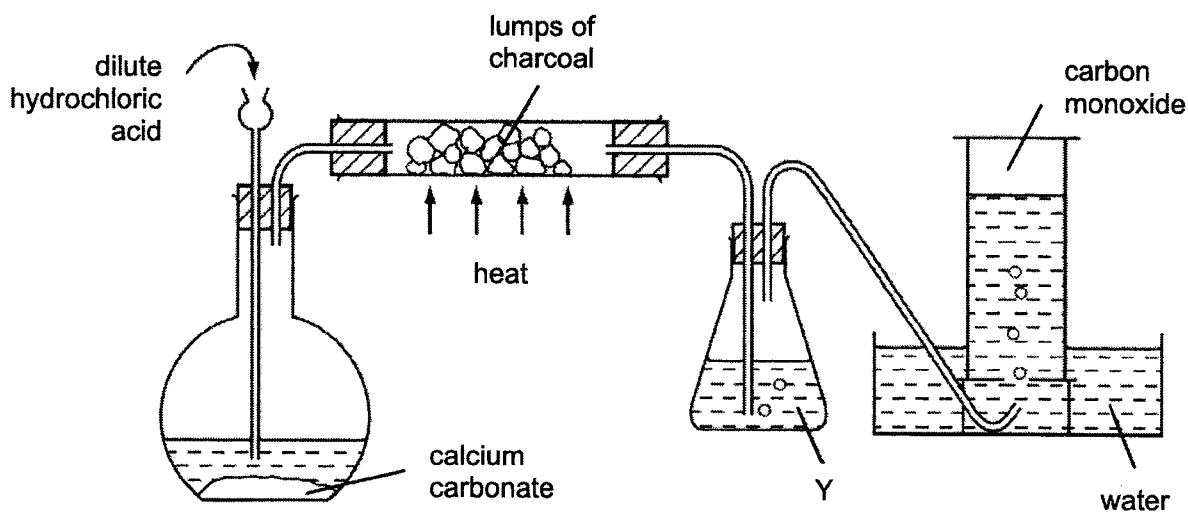

What is the main purpose of Y?

- A** to dry the gas
- B** to prevent water from being sucked back on to the hot charcoal
- C** to remove carbon dioxide from the gas
- D** to remove hydrogen chloride from the gas

3

- 3 The apparatus shown is used to distil ethanol from a mixture of ethanol and water.

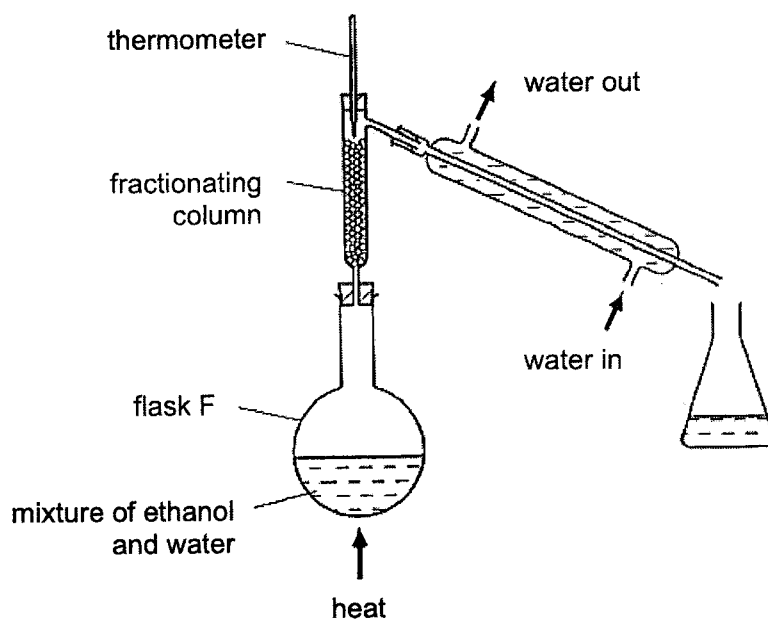

Which graph shows the change in concentration of ethanol in flask F over time?

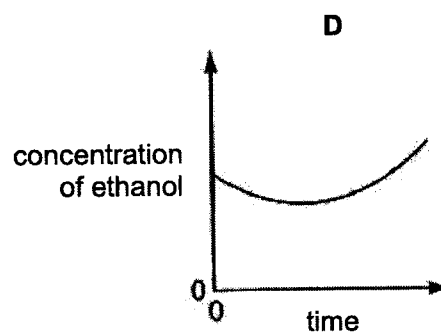
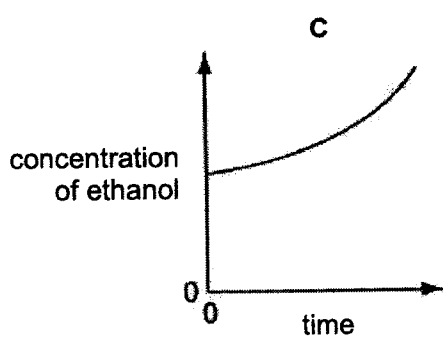
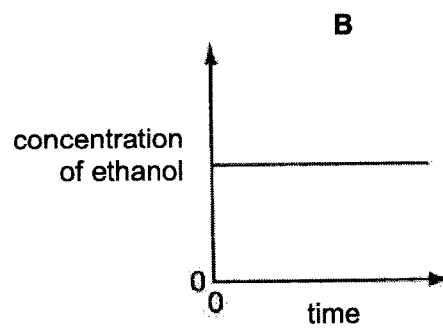
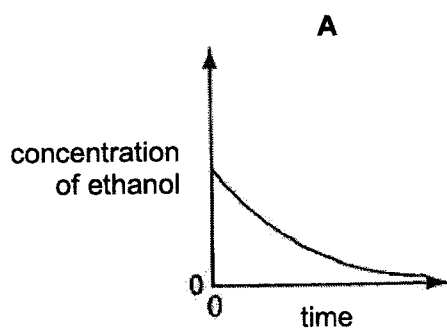

[Turn over

4

- 4 Aqueous sodium hydroxide was added to a mixture of an aqueous solution of Z. On warming, ammonia gas evolved. When aluminium foil is added to the reaction mixture and warmed, more ammonia gas was given off.

What could chemical Z be?

- A aluminium nitrate
 B aluminium sulfate
 C ammonium nitrate
 D ammonium sulfate
- 5 Some students are asked to describe differences between liquids and gases.

Four of their descriptions are:

- 1 Particles in liquid and gas are disorderly arranged.
- 2 Particles in gas are smaller than in liquid.
- 3 Particles in liquid vibrate about fixed positions.
- 4 When a force is applied, particles in gas are able to move closer together.

Which descriptions are correct?

- A 1 and 2 B 1 and 4 C 2 and 3 D 3 and 4
- 6 Which particle contains the same number of both neutrons and electrons?
- A ${}_{20}^{40}\text{Ca}^{2+}$ B ${}_{12}^{24}\text{Mg}^{2+}$ C ${}_{9}^{19}\text{F}^{-}$ D ${}_{16}^{32}\text{S}^{2-}$
- 7 Solid copper metal, aqueous copper(II) sulfate, solid graphite and molten sodium chloride will all conduct electricity.

Which pair will conduct electricity because they both contain mobile ions?

- A aqueous copper(II) sulfate and molten sodium chloride
 B solid copper metal and aqueous copper(II) sulfate
 C solid copper metal and solid graphite
 D solid graphite and molten sodium chloride

- 8 Which salt contains covalent bond?
- A ammonium chloride
 - B magnesium bromide
 - C potassium iodide
 - D sodium fluoride
- 9 Which statement explains why potassium chloride, KCl , has a lower melting point than calcium oxide, CaO ?
- A Potassium is more reactive than calcium.
 - B Potassium chloride has covalent bonds and calcium oxide has ionic bonds.
 - C The melting point of potassium is lower than that of calcium.
 - D The attraction between K^+ and Cl^- is weaker than Ca^{2+} and O^{2-} .

- 10 Bromoethane reacts with sodium hydroxide.

The equation for the reaction is shown.

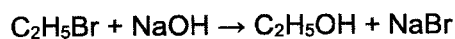

In an experiment, 10.90g of bromoethane is converted into 3.45g of ethanol.

What is the percentage yield of ethanol?

- A 32 %
- B 42 %
- C 75 %
- D 100 %

[Turn over

- 11 The diagram shows three balloons filled with different gases held by students. All gas volumes were measured at room temperature pressure.

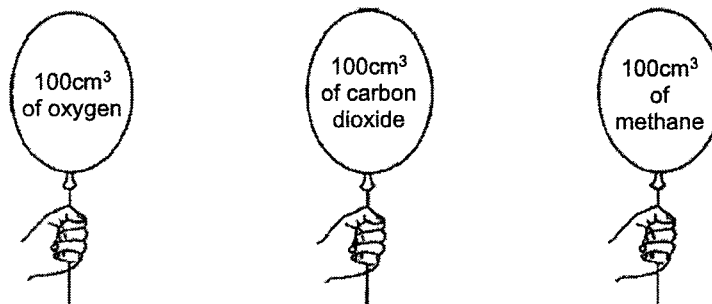

The students made the following statements.

- 1 The number of moles of gases in the 3 balloons is different.
- 2 The number of molecules in the 3 balloons is the same.
- 3 The mass of gases in the 3 balloons is different.

Which statements are correct?

- A 1 and 2
B 1 and 3
C 1, 2 and 3
D 2 and 3
- 12 A piece of chalk has a mass of 23.0 g. Chalk is impure calcium carbonate. When analysed, the chalk is found to contain 0.226 moles of pure calcium carbonate, CaCO₃.

What is percentage purity of the piece of chalk?

[*M_r*: CaCO₃, 100]

- A 0.983 % B 1.02 % C 77.0 % D 98.3 %

- 13 Aqueous copper(II) sulfate is electrolysed using copper electrodes. The current is constant and the anode is weighed at regular time intervals.

Which graph is obtained when the mass of the anode is plotted against time?

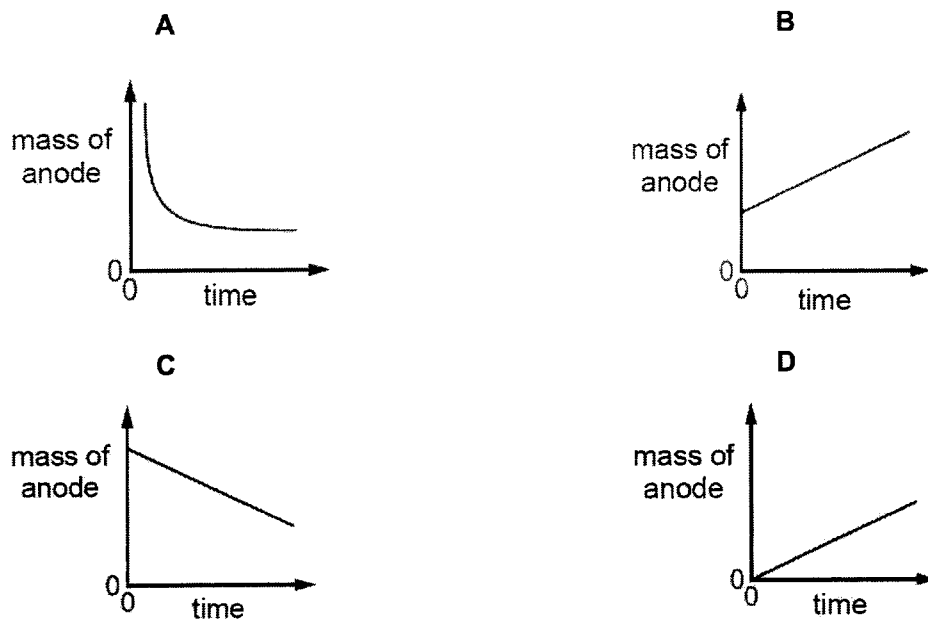

- 14 Three different processes using electrolysis with inert electrodes are listed.
- 1 electrolysis of concentrated aqueous sodium chloride
 - 2 electrolysis of dilute sulfuric acid
 - 3 electrolysis of dilute copper(II) chloride

Which processes form a gas at the cathode?

- A 1 and 2
 B 2 only
 C 2 and 3
 D 3 only

- 15 The energy profile diagram for the reversible reaction $2\text{SO}_2 + \text{O}_2 \rightleftharpoons 2\text{SO}_3$ is shown.

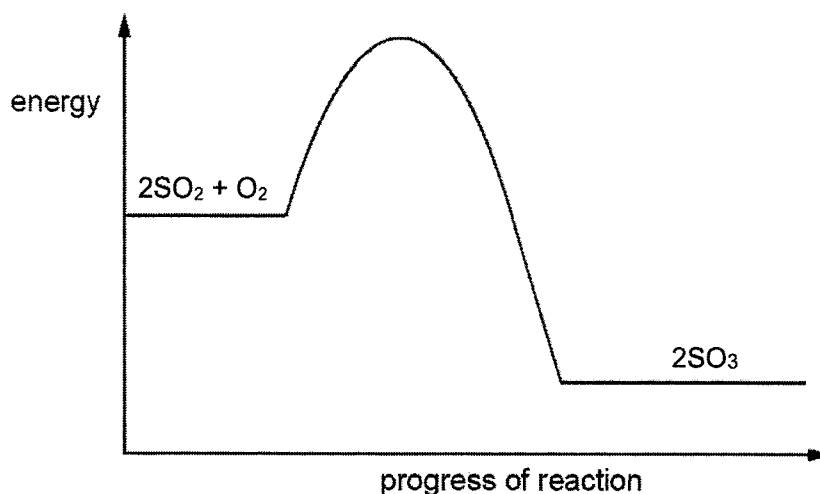

Which statements about this reaction are both correct?

	statement 1	statement 2
A	The reverse reaction is endothermic.	The activation energy is different for the forward and reverse reactions.
B	The reverse reaction is endothermic.	The activation energy is the same for the forward and reverse reactions.
C	The reverse reaction is exothermic.	The activation energy is different for the forward and reverse reactions.
D	The reverse reaction is exothermic.	The activation energy is the same for the forward and reverse reactions.

- 16 The table compares the strengths of bonds present in substances, P_2 , Q_2 and PQ_3 that are involved in the reaction shown.

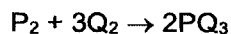

Which comparison of the strengths of the bonds will result in the most endothermic reaction?

	bonds in P_2	bonds in Q_2	bonds in PQ_3
A	strong	strong	weak
B	strong	weak	weak
C	weak	strong	strong
D	weak	weak	strong

- 17 In four separate experiments, 1, 2, 3 and 4, dilute nitric acid was added to excess marble chips and the volume of carbon dioxide formed was measured.

In all four experiments, the same volume of dilute nitric acid was used. Its concentration, or temperature, or both concentration and temperature, were changed.

The results of the experiments are shown on the graph.

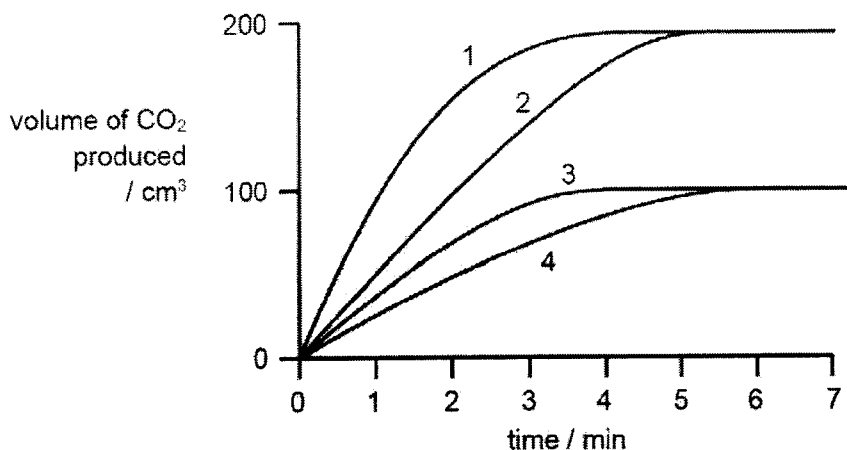

Which statement is correct?

- A A lower concentration of acid was used in experiment 1 than in experiment 3.
 B Experiment 4 was faster than experiment 3.
 C The acid used in experiment 2 was of a lower temperature than in experiment 1.
 D The temperature of the acid was the same in experiments 1 and 2.
- 18 Separate samples of a solution H is added to aqueous potassium iodide and to acidified potassium manganate(VII). The iodide ions remain unchanged and the manganate(VII) ions are reduced in the reaction.

What are the observations?

	aqueous potassium iodide	acidified potassium manganate(VII)
A	brown solution turns colourless	colourless solution turns purple
B	colourless solution turns brown	purple solution turns colourless
C	solution remains brown	solution remains colourless
D	solution remains colourless	purple solution turns colourless

[Turn over

- 19 Three elements X, Y and Z belong to the same period in the Periodic Table. The properties of their oxides are given in the table.

oxide of X:	soluble in both nitric acid and aqueous sodium hydroxide
oxide of Y:	insoluble in water and aqueous sodium hydroxide but dissolves readily in nitric acid
oxide of Z:	changes acidified potassium manganate(VII) from purple to colourless

Based on the statements above, arrange X, Y and Z in order of **decreasing** atomic numbers in the Periodic Table.

- A Y, X, Z
 B X, Y, Z
 C Z, Y, X
 D Z, X, Y
- 20 Four statements about acids were made.
- 1 Their pH value is less than 7.
 - 2 They are completely ionised when dissolved in water.
 - 3 They react with any metal to give hydrogen gas.
 - 4 Dibasic acids are stronger than monobasic acids.

Which statements must be true for all acidic solutions?

- A 1 only
 B 1 and 3
 C 1, 2 and 4
 D 1, 2, 3 and 4

- 21 Which reactants could be used safely to prepare sodium nitrate?
- A aqueous sodium hydroxide and dilute nitric acid
 B aqueous sodium sulfate and aqueous potassium nitrate
 C sodium and dilute nitric acid
 D sodium and aqueous potassium nitrate
- 22 Which statement about the manufacture of ammonia by the Haber Process is correct?
- A Nickel is used as a catalyst in this process.
 B The reactants and product are compounds.
 C The reactants are both obtained from the air.
 D A high yield is favoured by conditions of high pressure and low temperature.
- 23 Elements from Group IV of the Periodic Table are shown.

carbon
 silicon
 germanium
 tin
 lead
 flerovium

Which does **not** occur down Group IV?

- A The elements become more metallic.
 B The elements have more electron shells.
 C The number of outer shell electrons increases.
 D The proton number of the elements increases.
- 24 A new element, Gr, was discovered with the following properties.

solubility	electrical conductivity	formula of element	bonding in a molecule of the element
insoluble	does not conduct	Gr ₂	Gr ≡ Gr

Which group is Gr from?

- A Group III
 B Group V
 C Group VII
 D Group 0

[Turn over

25 Which pair of compounds shows that transition elements have variable oxidation states?

- A Cr_2O_3 and CrBr_3
- B CuSO_4 and CuCl_2
- C Fe_2O_3 and FeCl_2
- D NiO and NiCl_2

26 The bar chart shows the volume of hydrogen gas collected in 1.0 min when equal masses of metals E, F, G and H were added to excess dilute nitric acid

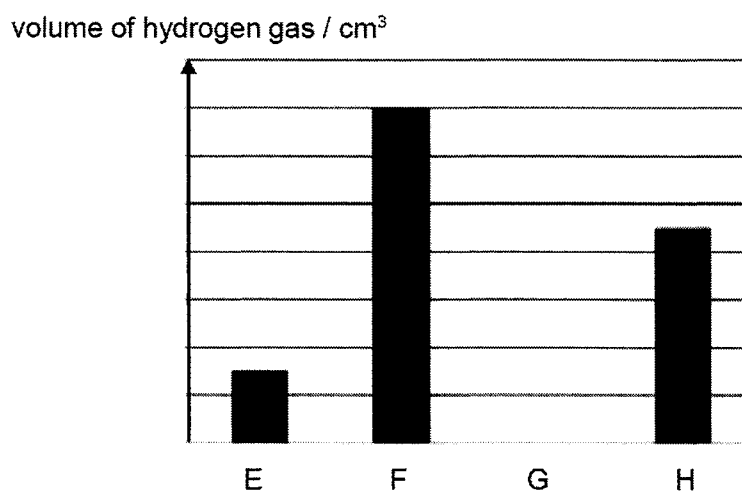

The carbonates of these metals were then heated.

Which row correctly shows the temperature required to decompose the carbonates in increasing order?

	increasing temperature →			
A	F	E	H	G
B	F	H	E	G
C	G	E	F	H
D	G	E	H	F

- 27 Which process removes carbon dioxide from the atmosphere?
- A combustion of fuels
 - B photosynthesis
 - C respiration
 - D volcanic activity

- 28 The list shows the position of metal Q in the reactivity series of metals.

Na Al Fe Q Cu Ag

Which method(s) could be used to extract metal Q?

- 1 electrolysis of the solid metal oxide
 - 2 heating the metal oxide with copper
 - 3 heating the metal oxide with carbon
- A 1, 2 and 3
 - B 1 and 3
 - C 2 and 3
 - D 3 only

[Turn over

- 29 Which diagram correctly shows the conditions required for rusting to take place and the metal used as sacrificial protection?

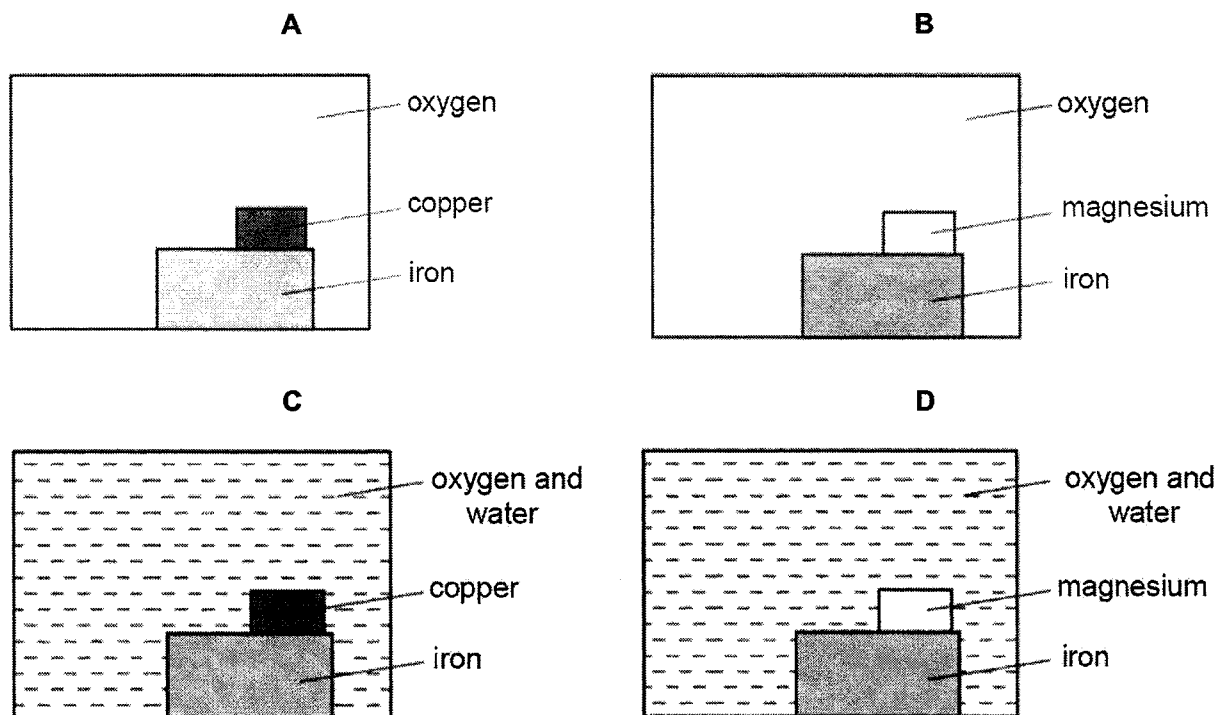

- 30 Petrol and diesel are two common fuels used by cars and buses respectively. The combustion of these fuels produces air pollutants.

The table shows the mass of pollutants found in the exhaust fumes when 1 kg of each fuel is burnt.

fuel	mass of pollutants/ g			
	carbon monoxide	oxides of nitrogen	sulfur dioxide	unburnt hydrocarbons
petrol	240	20	1	25
diesel	10	60	4	20

Which statement can be inferred from the table?

- A Petrol contributes more towards the formation of acid rain.
- B Carbon monoxide is produced by complete combustion of the fuels.
- C All the pollutants listed can be removed by installing a catalytic converter.
- D The temperature in the petrol engine is lower than that in the diesel engine.

- 31 Which method is the **least** effective method in reducing the amount of pollutant gases that cause acid rain?
- A Burning fuel with low sulfur content.
- B Reduce usage of air-conditioners.
- C Pass waste gases through catalytic converters in motor vehicles.
- D Use limestone to absorb pollutant gases from factories.

- 32 The table shows the boiling points of four fractions obtained when crude oil is distilled.

fraction	W	X	Y	Z
boiling point/ °C	35 – 75	80 – 145	150 – 250	greater than 250

Which statement describing the fractions is true?

- A Fraction W is more flammable than fraction Y.
- B Fraction W is more viscous than fraction Z.
- C The density of fraction X is greater than that of fraction Z.
- D The molecules in X have a longer chain length than those in fraction Z.
- 33 Several observations of an organic compound were made:

- liquid Br₂ remained brown when added to it in the dark
- there was no observable change when it was heated with acidified KMnO₄
- there was no observable change when it was added to Mg metal

Which is the organic compound?

A

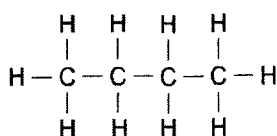

B

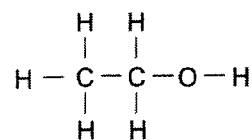

C

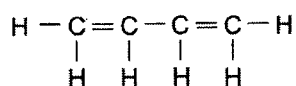

D

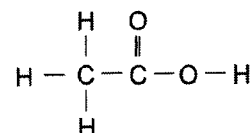

- 34 The table shows the reactions between chlorine and methane.

Which row shows the correct equation and condition of the reaction?

	equation	condition
A	$\text{Cl}_2 + \text{CH}_4 \rightarrow \text{CH}_2\text{Cl}_2 + \text{H}_2$	gases are mixed in the presence of UV light
B	$\text{Cl}_2 + \text{CH}_4 \rightarrow \text{CH}_2\text{Cl}_2 + \text{H}_2$	methane is bubbled into aqueous chlorine
C	$\text{Cl}_2 + \text{CH}_4 \rightarrow \text{CH}_3\text{Cl} + \text{HCl}$	gases are mixed in the presence of UV light
D	$\text{Cl}_2 + \text{CH}_4 \rightarrow \text{CH}_3\text{Cl} + \text{HCl}$	methane is bubbled into aqueous chlorine

- 35 When decane, $\text{C}_{10}\text{H}_{22}$, is cracked, only three compounds are formed.

The compounds are ethane, ethene and propene.

What is the ratio of the compounds formed?

	ethane	ethene	propene
A	1	1	1
B	1	1	2
C	1	2	1
D	2	1	1

- 36 One mole of hydrocarbon, J reacts with three moles of bromine to form a saturated organic compound.

What could be the molecular formula of J?

- A** C_3H_6
- B** C_4H_6
- C** C_5H_8
- D** C_6H_8

37 The properties of three substances are given:

- 1 an ester from an alcohol and a carboxylic acid
- 2 ethanol from ethene
- 3 margarine from vegetable oil

In which preparations are one or more double bonds converted to single bonds?

- A 1 and 2
 B 1 only
 C 2 and 3
 D 3 only

38 The graphs show the amount of various substances present in a mixture during the process of fermentation.

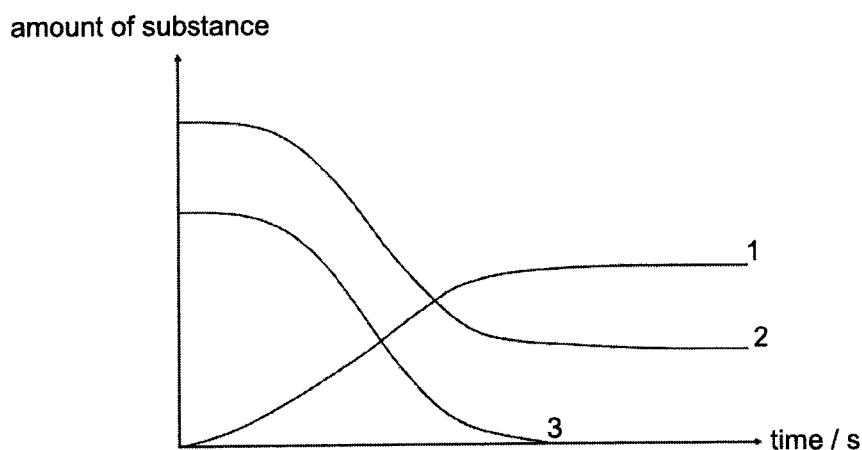

Which row shows the correct substance for each graph?

	graph 1	graph 2	graph 3
A	ethanol	yeast	glucose
B	glucose	yeast	ethanol
C	glucose	ethanol	yeast
D	ethanol	glucose	yeast

[Turn over

- 39 A food chemist wants to create the odour of pineapples using the organic compound,

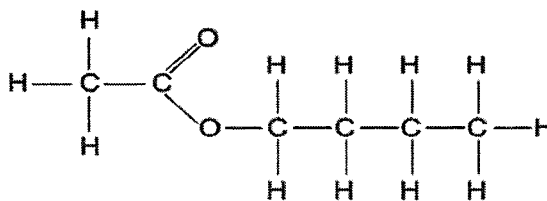

Which row correctly shows the pair of reactants that would react to form this compound and the name of the compound?

	reactant 1	reactant 2	name of the compound
A	CH ₃ CH ₂ OH	CH ₃ CH ₂ CH ₂ CH ₂ OH	ethyl butanoate
B	CH ₃ CH ₂ OH	CH ₃ CH ₂ CH ₂ COOH	ethyl butanoate
C	CH ₃ COOH	CH ₃ CH ₂ CH ₂ CH ₂ OH	butyl ethanoate
D	CH ₃ CH ₂ CH ₂ COOH	CH ₃ COOH	butyl ethanoate

- 40 The table refers to the polymers nylon and poly(ethene).

Which row is correct?

	polymer	type	use
A	nylon	addition	cling film
B	nylon	condensation	parachutes
C	poly(ethene)	addition	parachutes
D	poly(ethene)	condensation	cling film

The Periodic Table of Elements

		Group																																																																									
I	II	III	IV	V	VI	VII	0					0																																																															
3 Li lithium 7	4 Be beryllium 9	11 Na sodium 23	12 Mg magnesium 24	19 K potassium 39	20 Ca calcium 40	21 Sc scandium 45	22 Ti titanium 48	23 V vanadium 51	24 Cr chromium 52	25 Mn manganese 55	26 Fe iron 56	27 Co cobalt 59	28 Ni nickel 59	29 Cu copper 64	30 Zn zinc 65	31 Ga gallium 70	32 Ge germanium 73	33 As arsenic 75	34 Se selenium 79	35 Br bromine 80	36 Kr krypton 84	37 Rb rubidium 85	38 Sr strontium 88	39 Y yttrium 89	40 Zr zirconium 91	41 Nb niobium 93	42 Mo molybdenum 96	43 Tc technetium —	44 Ru ruthenium 101	45 Rh rhodium 103	46 Pd palladium 106	47 Ag silver 108	48 Cd cadmium 112	49 In indium 115	50 Sn tin 119	51 Sb antimony 122	52 Te tellurium 128	53 I iodine 127	54 Xe xenon 131	55 Cs caesium 133	56 Ba barium 137	57-71 lanthanoids	72 Hf hafnium 178	73 Ta tantalum 181	74 W tungsten 184	75 Re rhenium 186	76 Os osmium 190	77 Ir iridium 192	78 Pt platinum 195	79 Au gold 197	80 Hg mercury 201	81 Tl thallium 204	82 Pb lead 207	83 Bi bismuth 209	84 Po polonium —	85 At astatine —	86 Rn radon —	87 Fr francium —	88 Ra radium —	89-103 actinoids	104 Rf rutherfordium —	105 Db dubnium —	106 Sg seaborgium —	107 Bh bohrium —	108 Hs hassium —	109 Mt meitnerium —	110 Ds darmstadtium —	111 Rg roentgenium —	112 Cn copernicium —	113 Nh nihonium —	114 Fl flerovium —	115 Lv livermorium —	116 Ts tennessium —	117 Oh oganeson —	118 Og oganesson —
		Key proton (atomic) number atomic symbol name relative atomic mass		1 H hydrogen 1												2 He helium 4																																																											

lanthanoids

57 La lanthanum 139	58 Ce cerium 140	59 Pr praseodymium 141	60 Nd neodymium 144	61 Pm promethium —	62 Sm samarium 150	63 Eu europium 152	64 Gd gadolinium 157	65 Tb terbium 159	66 Dy dysprosium 163	67 Ho holmium 165	68 Er erbium 167	69 Tm thulium 169	70 Yb ytterbium 173	71 Lu lutetium 175
89 Ac actinium —	90 Th thorium 232	91 Pa protactinium 231	92 U uranium 238	93 Np neptunium —	94 Pu plutonium —	95 Am americium —	96 Cm curium —	97 Bk berkelium —	98 Cf californium —	99 Es einsteinium —	100 Fm fermium —	101 Md mendelevium —	102 No nobelium —	103 Lr lawrencium —

actinoids

The volume of one mole of any gas is 24 dm³ at room temperature and pressure (r.t.p.)



**YISHUN SECONDARY SCHOOL
PRELIMINARY EXAMINATION 2022
SECONDARY 4 EXPRESS**

CANDIDATE
NAME

CLASS

--	--	--

INDEX
NUMBER

--	--

CHEMISTRY
Paper 2

6092/02
29 August 2022
1 hour 45 minutes

Candidates answer on the Question Paper.
No Additional Materials are required.

READ THESE INSTRUCTIONS FIRST

Write your name, class and index number on the work you hand in.
Write in dark blue or black pen.
You may use an HB pencil for any diagrams or graphs.
Do not use staples, paper clips, glue or correction fluid.

Section A

Answer **all** questions in the spaces provided.

Section B

Answer **all three** questions. The last question is in the form either/or.
Write your answers in the spaces provided.

Electronic calculators may be used.

The number of marks is given in brackets [] at the end of each question or part question.
A copy of the Periodic Table is printed on page **20**.

The use of an approved scientific calculator is expected, where appropriate.

This document consists of **20** printed pages.

Section A

Answer **all** questions in this section in the space provided.
The total mark for this section is 50.

A1 The diagrams can be used to represent the structures of some organic compounds.

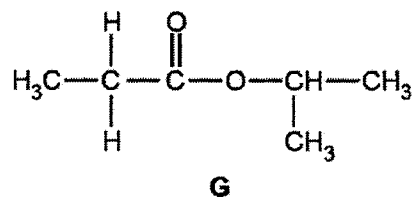
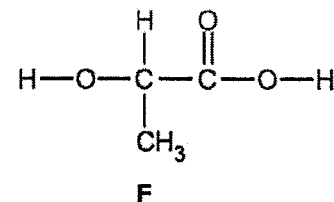
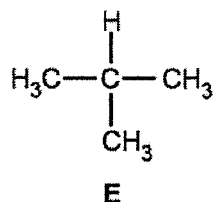
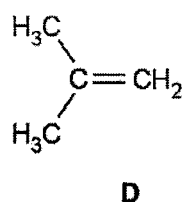
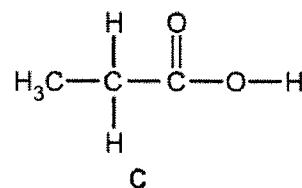
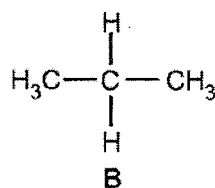
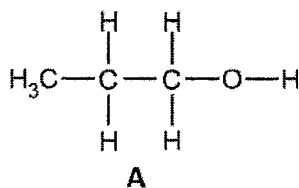

Each compound may be used once, more than once or not at all.

(a) State which compound:

(i) has a molecule with only 14 atoms

.....[1]

(ii) can be oxidised to form propanoic acid

.....[1]

(iii) is an isomer of butane

.....[1]

(iv) reacts with steam to make an alcohol

.....[1]

(b) State which **two** compounds in aqueous solution turn blue litmus red.

.....[1]

[total: 5]

- (c) Concentrated aqueous ammonia is used to make fertilisers such as ammonium sulfate, $(\text{NH}_4)_2\text{SO}_4$.

Aqueous ammonia reacts with dilute sulfuric acid.

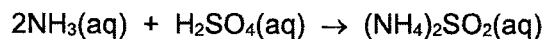

A student titrates 20.0 cm^3 of aqueous ammonia with 0.150 mol/dm^3 sulfuric acid.

10.5 cm^3 of sulfuric acid is required to neutralise the aqueous ammonia.

Calculate the concentration, in mol/dm^3 , of the aqueous ammonia.

[3]

[total: 9]

- A3** A student investigated the rate of a reaction using the apparatus and materials as shown. He also noted observations at regular time interval during heating.

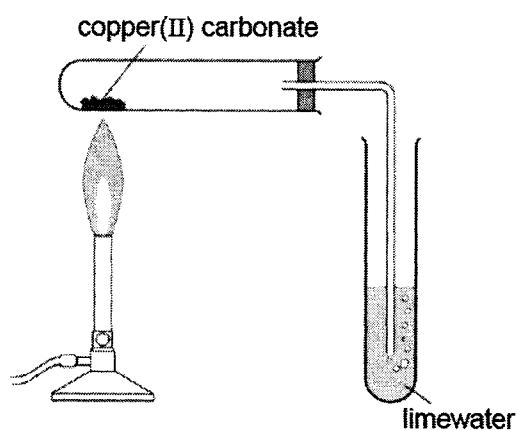

time interval / min	observations
0 – 1	A slow release of bubbles. No change observed in limewater. The solid in the test tube was green.
1 – 2	A fast release of bubbles. A change was observed in limewater at 1 minute 10 seconds. The solid turned black.
2 – 3	No release of bubbles. The solid in the test tube remained black after cooled.

(a) Explain the student's observation between

(i) zero and first minute

.....
.....[1]

(ii) first and second minute

.....
.....
.....[2]

(iii) second and third minute

.....
.....
.....[2]

(b) Explain how the observations would differ from the decomposition of copper(II) carbonate if the same number of moles of calcium carbonate is heated.

.....
.....
.....
.....
.....[3]

[total: 8]

A4 Table 4.1 shows some properties of *oxyacids* of chlorine.

Table 4.1

name of acid	chemical formula	reaction with magnesium (all acids have the same concentration)	oxidation state of chlorine
hypochlorous acid	HClO	only a few bubbles seen	
chlorous acid	HClO_2	reacts readily	
chloric acid	HClO_3	vigorous	
perchloric acid	HClO_4	very vigorous	

(a) Suggest why these acids are known as *oxyacids*.

.....
[2]

(b) Complete the table by filling in the oxidation states of chlorine. [2]

(c) State the relationship between the oxidation state of chlorine in the formula and the strength of the acid. Justify your answers with reference to Table 4.1

.....

[2]

(d) Suggest a method, beside observations, the student could use to follow the rate of the reaction.

.....
[2]

[total: 8]

- A5** Oxides of nitrogen are atmospheric pollutants. Nitrogen monoxide, NO, is formed in combustion engines when nitrogen and oxygen react together.

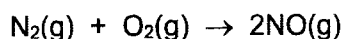

Fig. 5.1 shows the energy profile for this reaction.

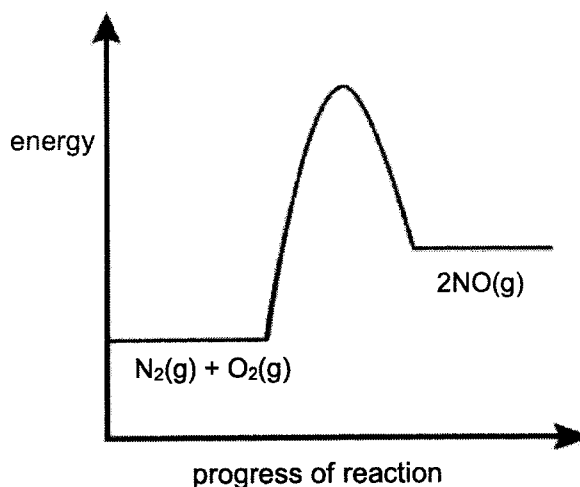

Fig. 5.1

- (a) Label clearly on Fig. 5.1 the reaction enthalpy change and the activation energy on the energy profile diagram. [2]

- (b) The reaction between nitrogen and oxygen is endothermic.

- (i) Explain how you can tell from the diagram that the reaction is endothermic.

.....[1]

- (ii) The year 2019 proved to be one of the hottest years on record in Singapore, with the annual mean temperature hitting 28.4 °C.

Describe and explain how a hotter day affects the activation energy of the formation of nitrogen monoxide in combustion engines.

.....

.....[2]

- (c) Cars have catalytic converters fitted to reduce pollution problems caused by some of the exhaust gases.

Write an equation to show one exhaust gas is converted to a harmless substance within the catalytic converter.

.....[1]

[total: 6]

- A6** Two metal electrodes and an electrolyte can be used to produce electrical energy.

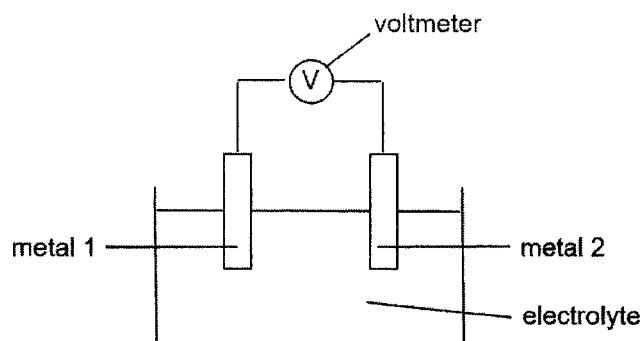

Table 6.1 shows the voltage produced by some cells when different metals are used.

Table 6.1

cell	metal 1	metal 2	voltage / V
1	copper	zinc	1.10
2	copper	magnesium	2.72
3	silver	zinc	1.56
4	silver	iron	1.25

- (a) In which direction does the electrons flow in the external wire of cell 3?

.....[1]

- (b) In terms of the reactions that take place in the cells, explain why the voltage of cell 2 is higher than cell 1.

.....

[2]

- (c) A chromatography of five substances was carried on the same chromatogram with both solvents **X** and **Y**.

The chromatogram was first run using solvent **X**. It was then turned 90° on its side where a second chromatogram using solvent **Y** was run.

On the chromatogram on Fig. 7.1,

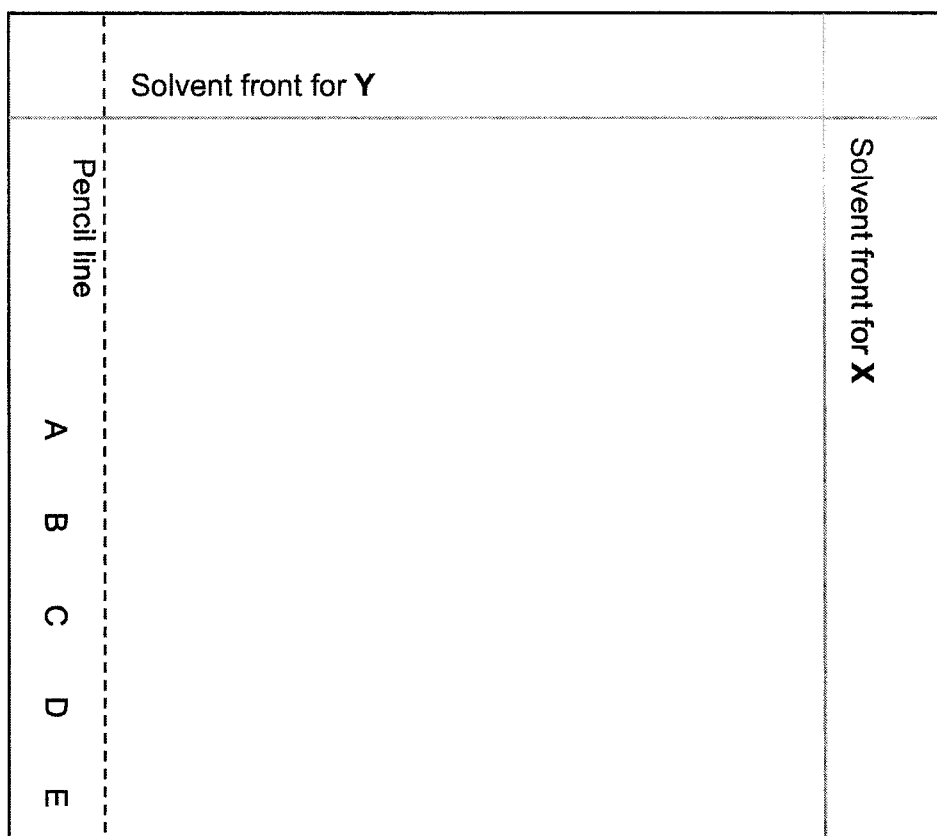

Fig. 7.1

- (i) Mark with a "**B**" where you would find the final spot formed by substance **B**. [1]
- (ii) Mark "**E**" where you would find the final spot formed by substance **E**. [1]
- (d) The use of a locating agent was required in the chromatography experiments.
Explain why a locating agent is used.

.....
[1]

[total: 6]

Section B

Answer all **three** questions in this section.

The last question is in the form of an either/or and only one of the alternatives should be attempted.

- B8** This question is about the chemistry of reactions occurring in hydrothermal vents that are found on the ocean floor.

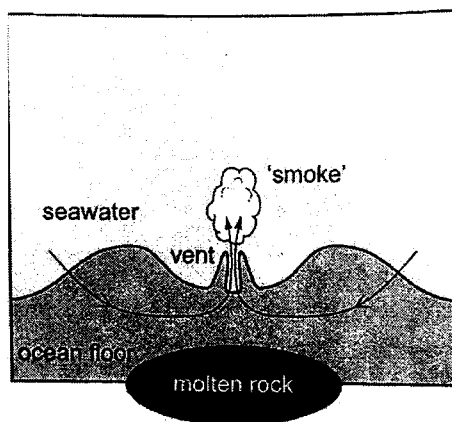

The diagram shows a hydrothermal vent. Seawater flows through the rocks in the ocean floor and is heated by molten rock below the surface. It then flows back out into the ocean through the hydrothermal vent, producing a cloud of 'smoke' consisting of precipitated solids.

The chemical composition of the water coming out of the vents is different from normal seawater.

Table 8.1 shows a typical composition of both types of water.

Table 8.1

	normal seawater	hydrothermal vent water
temperature / °C	2	350
pH	7.8	4.3
concentration of ions / $\times 10^{-3}$ mol/dm ³		
Cl ⁻	531	539
Na ⁺	450	419
Mg ²⁺	51.2	0.0
SO ₄ ²⁻	27.1	0.0
HCO ₃ ⁻	2.3	5.7
Ca ²⁺	9.9	15.1
K ⁺	9.5	22.5
Fe ²⁺	0.0	1.62
Mn ²⁺	0.0	0.93
Cu ²⁺	0.0	0.03
NH ₄ ⁺	0.0	0.03
concentration of gases / $\times 10^{-3}$ mol/dm ³		
O ₂	0.1	0.0
HCl	0.0	7.1
H ₂ S	0.0	1.7
CH ₄	0.0	0.1
He	0.0	2×10^{-6}

(a) (i) State which ions are removed from the seawater by the hydrothermal vent.
[1]

(ii) State which transition metal ions have been added to the water by the process.
[1]

(b) An environmentalist made the following statement: "The decrease in the concentration of the hydrogen ions is only due to the increase in the temperature of the water."

Using relevant data from Table 8.1, explain why the statement made by the environmentalist is incorrect.

.....

[3]

(c) The 'smoke' contains a variety of metal sulfides, which are precipitated when the hot hydrothermal vent water meets the cold seawater.

In one reaction, iron(II) disulfide, FeS₂, is formed in a redox reaction from iron(II) ions and hydrogen sulfide.



(i) Deduce which element is oxidised and which is reduced in this reaction.
 oxidised reduced [1]

(ii) Draw a 'dot-and-cross' diagram of hydrogen sulfide, showing the outer shell electrons only.

[2]

- (d) Normal seawater contains the salt sodium hydrogen carbonate which can be prepared in the science laboratory as shown below.

In the first experiment, 25.00 cm³ of 2.00 mol/dm³ dilute hydrochloric acid solution is added to completely react with 25.0 of 1.00 mol/dm³ aqueous sodium carbonate in a conical flask to produce sodium chloride, water and carbon dioxide gas as shown in the reaction.



The above reaction is said to proceed via these two steps:

step 1	$\text{HCl}(\text{aq}) + \text{Na}_2\text{CO}_3(\text{aq}) \rightarrow \text{NaHCO}_3(\text{aq}) + \text{NaCl}(\text{aq})$
step 2	$\text{HCl}(\text{aq}) + \text{NaHCO}_3(\text{aq}) \rightarrow \text{NaCl}(\text{aq}) + \text{H}_2\text{O}(\text{g}) + \text{CO}_2(\text{g})$

In a second experiment, 25.0 cm³ of the same dilute hydrochloric acid solution is placed inside a conical flask.

You are given the same aqueous sodium carbonate that was used in the first experiment.

State the minimum volume of aqueous sodium carbonate to be added in order to produce maximum number of moles of sodium hydrogen carbonate.

.....[1]

- (e) The gas from a hydrothermal vent contains helium with a slightly lower relative atomic mass than is normally found in the Earth's atmosphere.

- (i) Define the term *relative atomic mass*.

.....
[1]

- (ii) The relative atomic mass of the helium from a particular vent is exactly 4.0025959. The two naturally occurring isotopes of helium have the precise relative isotopic masses as shown in Table 8.2.

Table 8.2

isotope	relative isotopic mass
³ He	3.0160293
⁴ He	4.0026033

Calculate the percentage of ³He in the mixture.

[2]

[total: 12]

[Turn over

- B9** A precipitation reaction refers to the formation of an insoluble salt when two soluble salt solutions react. The insoluble salt that is produced is known as the precipitate. Barium hydroxide is an alkali solution which can be used in precipitation reaction. It has the following structure:



A study of a precipitation reaction between barium hydroxide and dilute sulfuric acid was conducted. The reaction tubes containing different volumes of barium hydroxide and dilute sulfuric acid. Precipitation occurs in all the reaction tubes and after 20 minutes, the height of the precipitate in each tube is measured and recorded in Table 9.1.

Table 9.1

reaction tube	1	2	3	4	5	6
volume of 0.25 mol/dm ³ barium hydroxide used / cm ³	5.0	5.0	5.0	5.0	5.0	5.0
volume of 0.50 mol/dm ³ dilute sulfuric acid used / cm ³	1.0	1.5	2.0	2.5	3.0	3.5
height of precipitate / cm	2.5	3.0	3.5	4.0	4.0	?

The electrical conductivity of each reaction tube is recorded and shown in the graph.

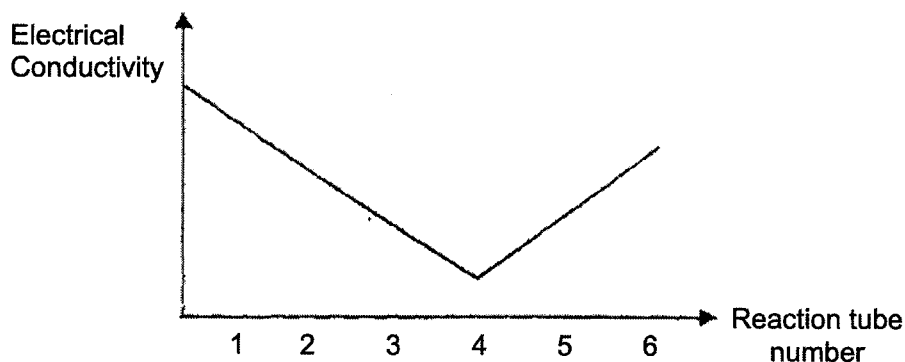

- (a) Write an ionic equation to represent the precipitation reaction.
[1]
- (b) Draw a 'dot-and-cross' diagram to show the bonding in a hydroxide ion, showing the outer shell electrons only.

[2]

- (c) Predict, with reason, the height of the precipitate and the colour of the Universal Indicator when added to reaction tube 6 after 20 minutes.

height of the precipitate

colour of Universal Indicator

reason

.....[2]

- (d) Describe and explain the shape of the electrical conductivity graph.

.....

.....

.....

.....

.....

.....[3]

[total: 8]

B10 Either

Table 10.1 shows some information on different types of plastics that are commonly used.

Table 10.1

	tensile strength (MPa)	density (g/cm ³)	number of years to break down the plastic
biopolymers	36	1.24	0.5
clear polystyrene	25	1.04	approximately 100
polycarbonates	55 – 75	1.20	1

Note: Tensile strength measures the resistance of a material to breaking under tension.

- (a) (i) Explain why biopolymers and polycarbonate have been used to replace polystyrene as plastics.

.....

[2]

- (ii) Give one disadvantage of using biopolymers as a plastic container to store food.

.....
[1]

- (b) Polystyrene is manufactured from phenylethene. The structure of phenylethene is shown.

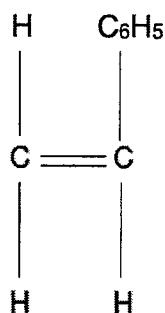

- (i) Explain how polystyrene could be obtained from phenylethene.

.....

[3]

- (ii) Draw the structural formula of polystyrene, showing two repeat units.

[1]

- (c) Biopolymers are renewable plastic materials manufactured from biomass such as corn, wheat, sugar cane and potatoes. An example of the structure of a type of biopolymer is shown below:

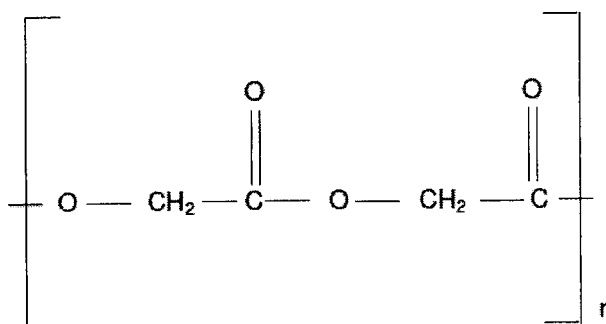

- (i) With reference to the linkage, what type of polymer is this biopolymer?
[1]
- (ii) Name one synthetic polymer that has a similar structure as this biopolymer.
[1]
- (iii) The biopolymer in (c) can be broken down easily to its monomer.
 Draw the structural formula of the monomer after the biopolymer is broken down.

[1]

[total: 10]

B10 Or

Both copper and magnesium are metals.

(a) Explain why magnesium reacts with hydrochloric acid but copper does not.

.....
[1]

(b) Brass is an alloy of copper and zinc. Table 10.2 shows how the composition of brass influences its relative strength.

Table 10.2

composition of brass		relative strength
% copper	% zinc	
90	10	2.6
80	20	3.0
70	30	3.3
60	40	3.6

How does the composition of brass affect its strength?

.....
[1]

(c) Use your knowledge of the structure of metals to explain why brass is stronger than pure copper. You may include a labelled diagram in your answer.

.....

[3]

(d) A 11.09 g sample of an oxide of copper contains 9.86 g of copper.
 Deduce the empirical formula of this oxide of copper.

empirical formula[2]

- (e) Water draining from the waste heaps around a copper mine is often blue due to the presence of hydrated copper(II) ions.

Describe and explain what would be observed if an iron bar is placed into a container filled with water containing hydrated copper(II) ions.

.....

.....

.....

.....

.....

.....

.....[3]

[total: 10]

The Periodic Table of Elements

I		Group										VII		0				
3 Li lithium 7	4 Be beryllium 9											5 B boron 11	6 C carbon 12	7 N nitrogen 14	8 O oxygen 16	9 F fluorine 19	10 Ne neon 20	
11 Na sodium 23	12 Mg magnesium 24											13 Al aluminium 27	14 Si silicon 28	15 P phosphorus 31	16 S sulfur 32	17 Cl chlorine 35.5	18 Ar argon 40	
19 K potassium 39	20 Ca calcium 40	21 Sc scandium 45	22 Ti titanium 48	23 V vanadium 51	24 Cr chromium 52	25 Mn manganese 55	26 Fe iron 56	27 Co cobalt 59	28 Ni nickel 59	29 Cu copper 64	30 Zn zinc 65	31 Ga gallium 70	32 Ge germanium 73	33 As arsenic 75	34 Se selenium 79	35 Br bromine 80	36 Kr krypton 84	
37 Rb rubidium 85	38 Sr strontium 88	39 Y yttrium 89	40 Zr zirconium 91	41 Nb niobium 93	42 Mo molybdenum 96	43 Tc technetium —	44 Ru ruthenium 101	45 Rh rhodium 103	46 Pd palladium 106	47 Ag silver 108	48 Cd cadmium 112	49 In indium 115	50 Sn tin 119	51 Sb antimony 122	52 Te tellurium 128	53 I iodine 127	54 Xe xenon 131	
55 Cs caesium 133	56 Ba barium 137	57-71 lanthanoids		72 Hf hafnium 178	73 Ta tantalum 181	74 W tungsten 184	75 Re rhenium 186	76 Os osmium 190	77 Ir iridium 192	78 Pt platinum 195	79 Au gold 197	80 Hg mercury 201	81 Tl thallium 204	82 Pb lead 207	83 Bi bismuth 209	84 Po polonium —	85 At astatine —	86 Rn radon —
87 Fr francium —	88 Ra radium —	89-103 actinoids		104 Rf rutherfordium —	105 Db dubnium —	106 Sg seaborgium —	107 Bh bohrium —	108 Hs hassium —	109 Mt meitnerium —	110 Ds darmstadtium —	111 Rg roentgenium —	112 Cn copernicium —	114 Fl flerovium —	116 Lv livermorium —				

Key
proton (atomic) number
atomic symbol
name
relative atomic mass

1
H
hydrogen
1

lanthanoids		57 La lanthanum 139	58 Ce cerium 140	59 Pr praseodymium 141	60 Nd neodymium 144	61 Pm promethium —	62 Sm samarium 150	63 Eu europium 152	64 Gd gadolinium 157	65 Tb terbium 159	66 Dy dysprosium 163	67 Ho holmium 165	68 Er erbium 167	69 Tm thulium 169	70 Yb ytterbium 173	71 Lu lutetium 175
actinoids		89 Ac actinium —	90 Th thorium 232	91 Pa protactinium 231	92 U uranium 238	93 Np neptunium —	94 Pu plutonium —	95 Am americium —	96 Cm curium —	97 Bk berkelium —	98 Cf californium —	99 Es einsteinium —	100 Fm fermium —	101 Md mendelevium —	102 No nobelium —	103 Lr lawrencium —

The volume of one mole of any gas is 24 dm³ at room temperature and pressure (r.t.p.)

Yishun Secondary School
 Mark Scheme
 Preliminary Examination 2022
 Secondary 4 Pure Chemistry
 Date of exam: 01/09/2022
 Setter: Ms Widayah

Answers to Paper 1

Qn	Answer	Explanation																				
1	C	Magnesium sulfate is a soluble salt and the preparation of magnesium sulfate involves reaction of excess magnesium carbonate with dilute sulfuric acid. Excess, unreacted magnesium carbonate need to be removed by filtration using filter funnel lined with filter paper. Followed by crystallization which require evaporating dish and tripod stand.																				
2	C	Reaction between hydrochloric acid and calcium carbonate produces carbon dioxide. The carbon dioxide produced is reacted with charcoal (carbon) to produce carbon monoxide. The purpose of Y is to neutralize the unreacted carbon dioxide with an alkali.																				
3	A	Ethanol (b.p 78 °C) has lower bpt than water, hence distilled first. As time progresses, more ethanol is distilled and collected as distillate. The concentration of ethanol at flask F decreases over time as more ethanol is distilled and water remained in flask F.																				
4	C	The first test is a cation test, when aq sodium hydroxide is added and warmed, ammonia gas is produced which shows the presence of ammonium ions. The second test is an anion test for nitrate ions. More ammonia gas is produced when aluminium metal is added showed the presence of nitrate ions. Z is ammonium nitrate.																				
5	B	1 Both liquid and gas particles are disorderly arranged. ✓																				
		2 Gas particles are smaller than liquid particles. <i>Size of a particles depends on the number of atoms of the gas and liquid particles. Gas particles can be bigger or smaller than liquid particles.</i> ×																				
		3 Liquid particles vibrate about fixed positions. <i>Liquid particles slide over other liquid particles.</i> ×																				
		4 When a force is applied, gas particles are able to move closer together. ✓																				
6	C	<table border="1"> <thead> <tr> <th></th> <th>No of electrons</th> <th>No of neutrons</th> <th>Ans</th> </tr> </thead> <tbody> <tr> <td></td> <td>18</td> <td>20</td> <td></td> </tr> <tr> <td></td> <td>10</td> <td>12</td> <td></td> </tr> <tr> <td></td> <td>10</td> <td>10</td> <td>✓</td> </tr> <tr> <td>$^{32}_{16}\text{S}^{2-}$</td> <td>18</td> <td>16</td> <td></td> </tr> </tbody> </table>		No of electrons	No of neutrons	Ans		18	20			10	12			10	10	✓	$^{32}_{16}\text{S}^{2-}$	18	16	
	No of electrons	No of neutrons	Ans																			
	18	20																				
	10	12																				
	10	10	✓																			
$^{32}_{16}\text{S}^{2-}$	18	16																				
7	A	<table border="1"> <thead> <tr> <th></th> <th>solid copper metal</th> <th>aqueous copper(II) sulfate</th> <th>solid graphite</th> <th>molten sodium chloride</th> </tr> </thead> <tbody> <tr> <td>conducts electricity</td> <td>mobile electrons</td> <td>mobile ions</td> <td>mobile electrons</td> <td>mobile ions</td> </tr> </tbody> </table>		solid copper metal	aqueous copper(II) sulfate	solid graphite	molten sodium chloride	conducts electricity	mobile electrons	mobile ions	mobile electrons	mobile ions										
			solid copper metal	aqueous copper(II) sulfate	solid graphite	molten sodium chloride																
conducts electricity	mobile electrons	mobile ions	mobile electrons	mobile ions																		

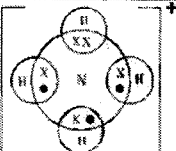
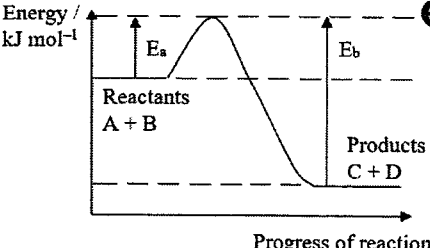
8	A	 <p>Ammonium ion has covalent bonding.</p>													
9	D	<ul style="list-style-type: none"> The attraction between K^+ and Cl^- is weaker than Ca^{2+} and O^{2-}. the electrostatic force in CaO is stronger than KCl because the number of charges in CaO is greater than in KCl A larger amount of energy is needed to overcome the electrostatic force in CaO than in KCl 													
10	C	<table border="1" style="width: 100%; border-collapse: collapse;"> <tbody> <tr> <td></td> <td colspan="2" style="text-align: center;">$C_2H_5Br + NaOH \rightarrow C_2H_5OH + NaBr$</td> </tr> <tr> <td>Mol ratio</td> <td style="text-align: center;">0.1 mol</td> <td style="text-align: center;">0.1 mol</td> </tr> <tr> <td>Theoretical yield</td> <td colspan="2" style="text-align: center;">$0.1 \times 46 = 4.6g$</td> </tr> <tr> <td>% yield</td> <td colspan="2" style="text-align: center;">$\frac{3.45}{4.6} \times 100\% = 75\%$</td> </tr> </tbody> </table>			$C_2H_5Br + NaOH \rightarrow C_2H_5OH + NaBr$		Mol ratio	0.1 mol	0.1 mol	Theoretical yield	$0.1 \times 46 = 4.6g$		% yield	$\frac{3.45}{4.6} \times 100\% = 75\%$	
	$C_2H_5Br + NaOH \rightarrow C_2H_5OH + NaBr$														
Mol ratio	0.1 mol	0.1 mol													
Theoretical yield	$0.1 \times 46 = 4.6g$														
% yield	$\frac{3.45}{4.6} \times 100\% = 75\%$														
11	D	<table border="1" style="width: 100%; border-collapse: collapse;"> <tbody> <tr> <td style="width: 5%; text-align: center;">1</td> <td style="width: 65%;">The number of moles of gases in the 3 balloons is different.</td> <td style="width: 30%;">× same vol of gas = same no of mol</td> </tr> <tr> <td style="text-align: center;">2</td> <td>The number of molecules in the 3 balloons is the same.</td> <td>✓ same no of mol = same no of molecules</td> </tr> <tr> <td style="text-align: center;">3</td> <td>The mass of gases in the 3 balloons is different.</td> <td>✓ different Mr for each gas</td> </tr> </tbody> </table>	1	The number of moles of gases in the 3 balloons is different.	× same vol of gas = same no of mol	2	The number of molecules in the 3 balloons is the same.	✓ same no of mol = same no of molecules	3	The mass of gases in the 3 balloons is different.	✓ different Mr for each gas				
1	The number of moles of gases in the 3 balloons is different.	× same vol of gas = same no of mol													
2	The number of molecules in the 3 balloons is the same.	✓ same no of mol = same no of molecules													
3	The mass of gases in the 3 balloons is different.	✓ different Mr for each gas													
12	D	<p>Mass of $CaCO_3 = 0.226$ moles Mass of $CaCO_3 = 0.226 \times 100 = 22.6$ g % purity = $\frac{22.6}{23.0} \times 100\% = 98.3\%$</p>													
13	C	Copper atoms in the copper anode oxidises to form Cu^{2+} ions in the electrolyte and the anode decreases in size, hence loses mass													
14	A	<table border="1" style="width: 100%; border-collapse: collapse;"> <thead> <tr> <th></th> <th style="text-align: center;">Cathode</th> <th style="text-align: center;">anode</th> </tr> </thead> <tbody> <tr> <td>electrolysis of concentrated aqueous sodium chloride</td> <td style="text-align: center;">Hydrogen</td> <td style="text-align: center;">chlorine</td> </tr> <tr> <td>electrolysis of dilute sulfuric acid</td> <td style="text-align: center;">Hydrogen</td> <td style="text-align: center;">water</td> </tr> <tr> <td>electrolysis of dilute copper(II) chloride</td> <td style="text-align: center;">Copper</td> <td style="text-align: center;">water</td> </tr> </tbody> </table>			Cathode	anode	electrolysis of concentrated aqueous sodium chloride	Hydrogen	chlorine	electrolysis of dilute sulfuric acid	Hydrogen	water	electrolysis of dilute copper(II) chloride	Copper	water
	Cathode	anode													
electrolysis of concentrated aqueous sodium chloride	Hydrogen	chlorine													
electrolysis of dilute sulfuric acid	Hydrogen	water													
electrolysis of dilute copper(II) chloride	Copper	water													
15	A	<p>The reverse reaction is endothermic and the activation energy is E_b as shown in the graph.</p>													
16	A	In endothermic reactions, more energy is absorbed to break bond of the reactants than energy released making bonds.													
17	C	Gradient in experiment 2 is gentler than 1 which indicates lower concentration													
18	D	Potassium iodide solution is colourless and a reducing agent. If the colour remain unchanged means no oxidising agent is present. Acidified potassium manganate(VII) is purple in colour and an oxidising agent. As it is reduced, the colour will change from purple to colourless.													

19	D	oxide of X:	soluble in both nitric acid and aqueous sodium hydroxide		Amphoteric oxide	Zinc oxide, lead(II) oxide, aluminium oxide									
		oxide of Y:	insoluble in water and aqueous sodium hydroxide but dissolves readily in nitric acid		Basic oxide	metals other than amphoteric oxide									
		oxide of Z:	changes acidified potassium manganate(VII) from purple to colourless		Reducing agent	Acidic oxide → non-metal oxides									
20	A	1	Their pH value is less than 7.		True										
		2	They are completely ionised when dissolved in water.		Some acids partially ionised acids in water such as ethanoic acid										
		3	They react with any metal to give hydrogen gas.		Some metals such as copper do not react with acids										
		4	Dibasic acids are stronger than monobasic acids.		Not all dibasic acids are stronger than mono basic acids										
21	A	Sodium nitrate is a SPA salt and method of preparation is titration. Titration involves the reaction between acids with alkali or metal carbonate													
22	D	Conditions for Haber process: • high temperature, 450°C, high pressure - about 200 atmospheres, and iron catalyst.													
23	C	As the elements are in Group IV, all the elements will have the same number of valence electrons, ie, 4 electrons													
24	B	Element has similar properties of nitrogen element, which has 5 valence electrons, and placed in Group V.													
		<table border="1" style="margin-left: auto; margin-right: auto;"> <thead> <tr> <th>electrical conductivity</th> <th>formula of element</th> <th>bonding in a molecule of the element</th> </tr> </thead> <tbody> <tr> <td>does not conduct</td> <td>Gr₂</td> <td>Gr ≡ Gr</td> </tr> <tr> <td>Non-metal</td> <td></td> <td>Similar to N₂ which has 5 valence electrons</td> </tr> </tbody> </table>					electrical conductivity	formula of element	bonding in a molecule of the element	does not conduct	Gr ₂	Gr ≡ Gr	Non-metal		Similar to N ₂ which has 5 valence electrons
electrical conductivity	formula of element	bonding in a molecule of the element													
does not conduct	Gr ₂	Gr ≡ Gr													
Non-metal		Similar to N ₂ which has 5 valence electrons													
25	C		O.S		O.S										
		Cr ₂ O ₃	Cr: +3	CrBr ₃	Cr: +3										
		CuSO ₄	Cu: +2	CuCl ₂	Cu: +2										
		Fe ₂ O ₃	Fe: +3	FeCl ₂	Fe: +2										
		NiO	Ni: +2	NiCl ₂	Ni: +2										
26	D	<p>The higher volume of hydrogen gas collected means the more reactive the metal is. Order of reactivity from least reactive to most reactive: F, H, E, G</p> <p>Metals higher in the reactivity series form metal carbonate which are more heat stable and requires very high temperature to thermally decompose. Metals lower in the reactivity series form carbonates which are less heat stable and require low temperature to thermally decompose.</p>													
27	B	In the carbon cycle, carbon dioxide in the atmosphere is removed by photosynthesis.													
28	D	As metal X is between Fe and Cu, X can be extracted using the reducing metal oxide using carbon													

29	D	For rusting to take place, oxygen (air) and water is required For sacrificial corrosion, the metal attached must be more reactive than iron
30	D	As the mass of oxides of nitrogen produced by petrol is 1/3 of diesel, that shows that the petrol engine is running on a lower temperature than diesel.
31	B	Reduce usage of air-conditioners will mean using less electricity. However, this activity does not tell the type of the source of electricity.
32	A	As fraction W has the lowest boiling point range, this means that it is most flammable.
33	A	<ul style="list-style-type: none"> liquid Br₂ remained brown when added to it in the dark >> absence of C=C there was no observable change when it was heated with acidified KMnO₄ >> not an alcohol there was no observable change when it was added to Mg metal >> not carboxylic acid
34	C	One of the products of substitution reaction is HCl. The reactants are in gaseous state in the presence of UV light.
35	B	Cracking of decane $\text{C}_{10}\text{H}_{22} \rightarrow \text{C}_2\text{H}_6 + \text{C}_2\text{H}_4 + 2\text{C}_3\text{H}_6$ Mole ratio is $1 \quad 1 \quad 1 \quad 2$
36	D	J : Br ₂ 1 : 3, this shows that there are 3 pairs of C=C. Using all the options available, C ₆ H ₈ fits the mol ratio
37	C	Carboxylic acid has a double bond in $\text{C}=\text{O}$. Esters has a double bond in $\text{C}=\text{O}$. Ethene has C=C. Ethanol does not have double bond Vegetable contains C=C bonds. Margarine is saturated and contains C-C bonds.
38	A	During fermentation, all the glucose will react and converted to ethanol. The amount of yeast will reduce and remain the same after some time.
39	C	From the diagram, the acid is ethanoic acid and the alcohol is butanol.
40	B	Correct method of production and the correct use of the plastics

Yishun Secondary School
 Mark Scheme
 2022 4E Chemistry Preliminary Examination
 Date of exam: P2 – 29 August 2022
 Setter: P2 - Mrs Ow PH

Answers to Paper 2

Qn no.	Key Answers	Remarks
1ai	E	1
ii	A	1
iii	E	1
iv	D	1
b	C and F	1
2a	<p>Evaporation occurs and the molecules escapes from the surface of the liquids. [1]</p> <p>Ammonia has a lower relative molecular mass of 17 compared to hydrochloric acid, which has a relative molecular mass of 36.5. [1]</p> <p>Ammonia diffuses faster than hydrogen chloride, the white fumes is formed closer to hydrochloric acid. [1]</p>	3
bi	250 atm and 450 °C, iron as catalyst [1]	1 reject iron(II)
ii	<p>Air is made up of a mixture of many gases, like oxygen and nitrogen. [1]</p> <p>Oxygen can react with hydrogen to form water if air is used during Haber process. / Carbon dioxide in air can react with ammonia / Nitrogen reacts with oxygen to form oxides of nitrogen / Air contains oxygen which oxidises iron catalyst to iron(II) oxide/iron(III) oxide Iron react with oxygen and water and rusting occurs. [1] (hence lower the yield of ammonia)</p>	2
c	<p>No of mole of $\text{H}_2\text{SO}_4 = 10.5/1000 \times 0.150 = 0.001575 \text{ mol}$ [1]</p> <p>$\text{H}_2\text{SO}_4 : \text{NH}_3$ 1 : 2 0.001575 : 0.00315 mole ratio [1]</p> <p>Concentration of $\text{NH}_3 = 0.00315/0.020 = 0.1575 \text{ mol/dm}^3$ [1]</p>	3 allow ECF
3ai	(beginning of <u>thermal decomposition</u>) particles absorbing energy to reach activation energy / low rate of reaction / not enough CO_2 produced to form white precipitate in limewater (OTTW)	1 reject oxygen
ii	<p><u>thermal decomposition</u> at the <u>fastest rate</u>; [1] <u>carbon dioxide given off and copper(II) oxide (black solid) formed</u>; [1] <u>carbon dioxide forms white precipitate with limewater</u>; [1]</p>	reject cloudy/milky max 2m
iii	<p><u>thermal decomposition stopped</u>; [1] <u>copper(II) carbonate completely decomposed</u>; [1] <u>copper(II) oxide left behind</u>; [1]</p>	max 2m reject reaction is completed

	<i>the term "thermal decomposition" must appear at least once in (i) – (iii) to get total 5m</i>																					
b	rate of reaction would be slower / time taken is longer; [1] as calcium carbonate is <u>more heat-stable</u> ; [1] solid remains white upon thermal decomposition; [1]	3																				
4a	contains oxygen [1] can dissociate in water to form H ⁺ ions [1]																					
b	<table border="1"> <thead> <tr> <th>name of acid</th> <th>chemical formula</th> <th>reaction with magnesium (all acids have the same concentration)</th> <th>oxidation state of chlorine</th> </tr> </thead> <tbody> <tr> <td>hypochlorous acid</td> <td>HClO</td> <td>only a few bubbles seen</td> <td>+1</td> </tr> <tr> <td>chlorous acid</td> <td>HClO₂</td> <td>reacts readily</td> <td>+3</td> </tr> <tr> <td>chloric acid</td> <td>HClO₃</td> <td>vigorous</td> <td>+5</td> </tr> <tr> <td>perchloric acid</td> <td>HClO₄</td> <td>very vigorous</td> <td>+7</td> </tr> </tbody> </table>	name of acid	chemical formula	reaction with magnesium (all acids have the same concentration)	oxidation state of chlorine	hypochlorous acid	HClO	only a few bubbles seen	+1	chlorous acid	HClO ₂	reacts readily	+3	chloric acid	HClO ₃	vigorous	+5	perchloric acid	HClO ₄	very vigorous	+7	2m for all correct 1m for 2-3 correct 0m for 1 correct
name of acid	chemical formula	reaction with magnesium (all acids have the same concentration)	oxidation state of chlorine																			
hypochlorous acid	HClO	only a few bubbles seen	+1																			
chlorous acid	HClO ₂	reacts readily	+3																			
chloric acid	HClO ₃	vigorous	+5																			
perchloric acid	HClO ₄	very vigorous	+7																			
c	Strength of acid <u>increases</u> as OS of Cl <u>increases</u> [1] When OS of Cl increases from +1 to +7, the reaction between the acid and Mg become more vigorous. [1]	2 reject direct relationship																				
d	measure the volume of H ₂ produced /loss in mass at a regular interval [1] plot volume of gas vs time on a graph [1]	2																				
5a	<p><i>spell out activation energy and enthalpy change</i></p>	2 reject Ea and/or ΔH																				
bi	the energy level of the reactants is <u>lower</u> than that of product / energy absorbed is more than energy released	1																				
ii	no effect [1] only the use of a catalyst can lower activation energy (of a reaction); OR activation energy is not affected by energy levels of particles; [1]	2																				
c	2CO + O ₂ → 2CO ₂ OR	1																				

	$2\text{NO} + 2\text{CO} \rightarrow \text{N}_2 + 2\text{CO}_2$ OR $2\text{NO}_2 + 4\text{CO} \rightarrow \text{N}_2 + 4\text{CO}_2$										
6a	electrons flow from <u>zinc metal to silver metal</u>	1 reject clockwise and anticlockwise									
b	<p>increasing order of reactivity: Cu, Zn, Mg the <u>larger the difference in reactivity</u> between the metal electrodes, the <u>larger the voltage</u> form [1]</p> <p>in both cells, reduction occurs at the copper electrode. <u>Extend of oxidation/ionisation is higher</u> at the magnesium electrode in cell 2 than at the zinc electrode in cell 1 [1] <i>voltage = electromotive force</i></p>	2									
c	<table border="1" style="margin-left: auto; margin-right: auto;"> <thead> <tr> <th>metal 1</th> <th>metal 2</th> <th>predicted voltage / V</th> </tr> </thead> <tbody> <tr> <td>copper</td> <td>iron</td> <td style="text-align: center;">0.79</td> </tr> <tr> <td>silver</td> <td>magnesium</td> <td style="text-align: center;">3.18</td> </tr> </tbody> </table> <p>voltage between silver and copper = $1.56 - 1.10 = 0.46\text{V}$</p> <p>hence voltage between copper and iron = 1.25 (silver to iron) $- 0.46 = 0.79\text{V}$</p> <p>hence voltage between silver and magnesium = 2.72 (copper to magnesium) $+ 0.46 = 3.18\text{V}$</p>	metal 1	metal 2	predicted voltage / V	copper	iron	0.79	silver	magnesium	3.18	1m each
metal 1	metal 2	predicted voltage / V									
copper	iron	0.79									
silver	magnesium	3.18									
d	<p>in <u>sodium chloride</u> solution, the <u>zinc electrode oxidised to form Zn^{2+} ions</u>, causing <u>a decrease in the mass</u> [1], while <u>hydrogen ions (H^+) are preferentially discharged</u> at copper electrode, hence causing no change in the mass [1]</p> <p>in <u>copper(II) chloride</u> solution, <u>Cu^{2+} is preferentially discharged</u>, as it is lower in the electrochemical series than H^+, forming copper metal which is deposited on the copper electrode [1]</p>	max 3 m									
7a	<p>Substance B is insoluble in solvent Y. [1]</p> <p>With a <u>R_f value of 0.00</u>, substance B did not move along the chromatogram and hence it is insoluble in solvent Y. [1]</p>	2									
b	<p>Solvent Y was used.</p> <p>Substances A and D have the same R_f values in solvent X and therefore will not form distinct spots on a chromatogram. To separate substance A and D, solvent Y would have to be used. [1]</p>	1									

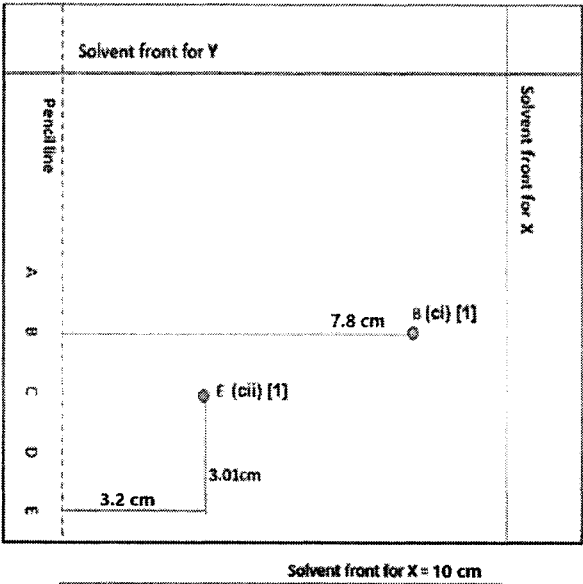
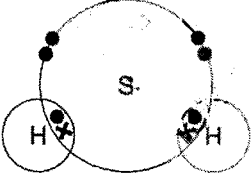
C	 <p>Solvent front for Y = 9.4 cm</p> <p>Solvent front for X = 10 cm</p> <p>Pencil line</p> <p>A</p> <p>B</p> <p>C</p> <p>D</p> <p>E</p> <p>7.8 cm B (ci) [1]</p> <p>3.01 cm E (cii) [1]</p> <p>3.2 cm</p>	
d	The locating agent forms coloured product with <u>colourless</u> substance tested for and could be <u>highlighted/seen/visible</u> in a chromatogram.	1
8ai	Mg^{2+} and SO_4^{2-} ions	1
ii	Fe^{2+} , Mn^{2+} and Cu^{2+}	1
b	<p>as temperature increases from 2 °C to 350 °C, the pH decreases from 7.8 to 4.3 [1]</p> <p>indicating that the concentration of hydrogen ions increases [1]</p> <p>however the concentration of hydrogen ions also increase due to the presence of hydrogen chloride, which dissolves in hydrothermal vent water to form hydrogen ions (and hydrogen sulfide) [1]</p> <p>hence, temperature is not the only factor</p>	3
ci	oxidised: sulfur reduced: hydrogen	1
ii	 <p>Legend</p> <p>● Electron from sulfur</p> <p>x Electron from hydrogen</p> <p>1 m for correct number of shared electrons</p> <p>1 m for correct number of valence electrons on each atom</p>	2
d	add 50.0 cm ³ of aqueous sodium carbonate (since the vol of acid remains unchanged)	
ei	average mass of 1 isotope/atom of an element compared to $\frac{1}{12}$ of the mass of a ¹² C atom	1
ii	let % of ³ He be x	2

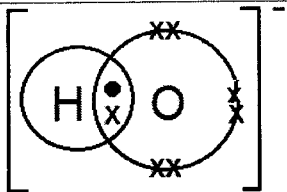
	$\frac{x}{100} (3.0160293) + \frac{100-x}{100} (4.0026033) = 4.0025959 \text{ [1]}$ $\frac{3.0160293x + 400.26033 - 4.0026033x}{100} = 4.0025959$ $0.986574x = 0.00074$ $x = 0.0750 \% \text{ [1]}$	
9a	$\text{Ba}^{2+} (\text{aq}) + \text{SO}_4^{2-} (\text{aq}) \rightarrow \text{BaSO}_4 (\text{s})$	1
b	 <p>1 m for number of electrons shared 1 m for correct number of valence electrons + charge</p>	2
c	height of precipitate: 4.0 cm; colour of indicator: red } [1]	2
	Barium hydroxide is used up and dilute sulfuric acid is in excess . [1] Hence, the height of precipitate remains at 4.0 cm and the pH of solution is approximately 2.0.	
d	<ul style="list-style-type: none"> The electrical conductivity <u>decreases from tube 1 to 4</u> and <u>increase from tube 5 to 6</u>. [1] As more dilute sulfuric acid is used, more <u>barium sulfate precipitate</u>, which does not conduct electricity is formed. Hence, the <u>number of free-moving ions decreases</u>. Formation of water molecules also reduces electrical conductivity as water does not conduct electricity well. [1] The <u>conductivity increases</u> from tube 5 to 6 as <u>excess acid</u> is present which dissociates to form free-moving ions. [1] 	3
10	either	
ai	They have higher tensile strength/ stronger and will not break easily [1] (when compared to polystyrene) Take a shorter time to be broken down hence it takes up less space in landfills/cut down the need to build more landfills/ less land pollution ; (when compared to polystyrene) [1]	2
ii	Biopolymers will break down in 0.5 years, this limits the use of biopolymers as it breaks down it will affect the quality of the food;	1
bi	Phenylethene undergoes addition polymerization [1] The carbon-carbon double bonds present in the phenylethene is being broken [1]	3

	and many phenylethene molecules joined together to become one giant macromolecule (of polystyrene) [1]	
ii		1
ci	polyester	1
ii	Terylene	1
iii	<p style="text-align: right;"><i>all bonds must be shown</i></p>	1
10	or	
a	magnesium loses (outer shell) electrons more easily than copper / copper cannot give (outer shell) electrons to hydrogen ions but magnesium can / <u>magnesium more reactive than hydrogen while copper less reactive than hydrogen</u> ;	1 A magnesium more reactive than copper
b	the higher % Zn, the greater the strength / the lower % Cu, the lower the strength ;	1
c	<p>zinc atom</p> <p>copper atom</p> <p><u>layers</u> (of atoms) in copper can slide (when a force is applied) [1]</p> <p><u>atoms/ions</u> of zinc are <u>different size</u> to those of copper/atoms of zinc disrupt the copper lattice [1]</p> <p><u>layers</u> (of atoms) in alloy cannot slide (as easily) [1]</p>	max 3m diagram must show disruption to orderly structure
d	Cu ₂ O ; 1m for working (calculate number of moles) 1m for mole ratio;	2

e	<p>Solution turns from <u>blue to pale green/lighter</u> in colour [1]</p> <p><u>Pink/brown/reddish brown solid</u> is formed on the iron bar [1]</p> <p><u>Iron is more reactive than copper</u> and will displace copper from copper(II) salt solution [1]</p>	3
---	--	---