



GUANGYANG SECONDARY SCHOOL
PRELIMINARY EXAMINATION 2022
 Secondary Four Express

CANDIDATE
NAME

CENTRE
NUMBER

INDEX
NUMBER

CLASS/
REG No.

 /

CHEMISTRY

Paper 1 Multiple Choice

6092/01

31 August 2022

1 hour

Additional Materials: Multiple Choice Answer Sheet
 Periodic Table

READ THESE INSTRUCTIONS FIRST

Write in soft pencil.

Do not use staples, paper clips, highlighters, glue or correction fluid.

Write your name, centre number, index number, class and register number in the spaces above.

There are **forty** questions on this paper. Answer all questions.

For each question there are four possible answers, **A, B, C** and **D**.

Read the instructions on the Answer Sheet carefully.

Each correct answer will score one mark. A mark will not be deducted for a wrong answer.

Any rough working should be done in this booklet.

The use of an approved scientific calculator is expected, where appropriate.

This question paper consists of 16 printed pages, inclusive of this cover page

Y

PAPER 1 (40 MARKS)

This paper consists of 40 multiple-choice questions. For each question, there are four possible answers. Choose the best answer you consider correct and record your answer on the Answer Sheet provided.

- 1 Copper (II) nitrate is soluble in water. Copper (II) carbonate is insoluble in water. A mixture of solid copper (II) nitrate and copper(II) carbonate is added to a beaker of water. It is stirred until no more solid dissolves. How can separate samples of copper (II) nitrate and copper (II) carbonate be obtained from the resulting mixture?
- A crystallisation followed by distillation
 - B evaporation followed by distillation
 - C evaporation followed by filtration
 - D filtration followed by crystallisation
- 2 A mixture of three liquids is separated by fractional distillation. Which statements are **correct**?
- 1 The mixture boils at constant temperature throughout the separation.
 - 2 The temperature at which the mixture boils increases during the separation.
 - 3 The liquid with the highest boiling point is collected first.
 - 4 The liquid with the lowest boiling point is collected first.
- A 1 and 3
 - B 1 and 4
 - C 2 and 3
 - D 2 and 4
- 3 It is possible to produce Ar^{2+} ions from argon atoms in a laboratory. Which statement is **correct**?
- A Each argon atom gains two electrons and loses the electronic configuration of an inert gas.
 - B Each argon atom gains two electrons and obtains the electronic configuration of an inert gas.
 - C Each argon atom loses two electrons and loses the electronic configuration of an inert gas.
 - D Each argon atom loses two electrons and obtains the electronic configuration of an inert gas.
- 4 Two isotopes of chlorine are ^{35}Cl and ^{37}Cl . Using these isotopes, how many different relative molecular masses are possible for the compound with molecular formula $\text{C}_2\text{H}_3\text{Cl}_3$?
- A 2
 - B 3
 - C 4
 - D 5

- 5 The diagram below shows a fractionating column used in the separation of petroleum.

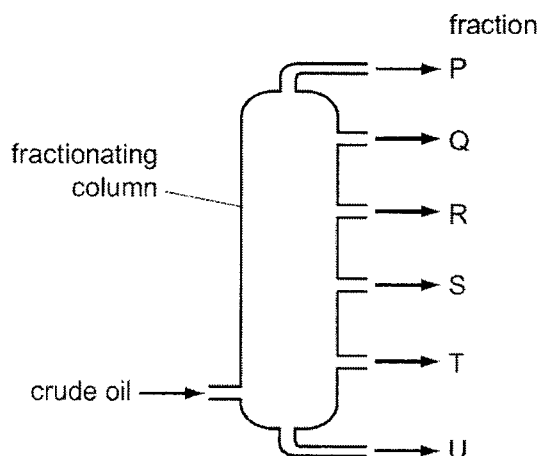

Which row explains why fraction R is collected above fraction S?

	boiling point of R	average molecular mass of R
A	greater than S	greater than S
B	greater than S	smaller than S
C	smaller than S	greater than S
D	smaller than S	smaller than S

- 6 The table shows data for some particles. There are gaps represented by W, X, Y and Z.

particle	proton number	nucleon number	number of neutrons	number of electrons
Ar	18	40	W	18
K ⁺	19	39	20	X
Sc	21	Y	24	21
S ²⁻	16	32	16	Z

Which row shows the correct values for W, X, Y and Z?

	W	X	Y	Z
A	20	20	42	14
B	20	20	42	16
C	22	18	45	14
D	22	18	45	18

- 7 The energy profile diagram of a chemical reaction is shown below.

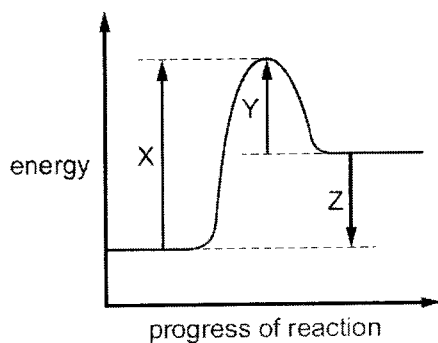

Which statement is **correct**?

- A The reaction is exothermic.
 - B Y represents ΔH for the reaction.
 - C X represents the activation energy for the reaction.
 - D Z represents the energy given out as the reaction proceeds.
- 8 Three statements about the elements carbon, nitrogen and sulfur are shown below.
- 1 They are in groups next to each other in the Periodic Table.
 - 2 Their neutron to proton ratios are all two to one.
 - 3 They each form an acidic oxide.

Which statements are **correct**?

- A 1, 2 and 3
 - B 1 and 2 only
 - C 1 and 3 only
 - D 2 and 3 only
- 9 When K_2MnO_4 is dissolved in water, the following reaction occurs.

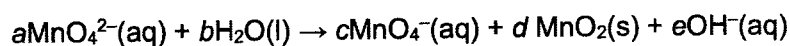

What could be the values of a and c in the balanced chemical equation?

	a	c
A	2	1
B	3	1
C	3	2
D	4	3

- 10 Many elements and compounds contain covalent bonds.
Which statement about covalently bonded elements and compounds is **correct**?
- A Aqueous solutions of covalent compounds always conduct electricity.
 B Bonding in the nitrogen molecule involves three shared pairs of electrons.
 C Double covalent bonds are present in ethene and in water.
 D The formation of covalent bonds always produces atoms with eight electrons in their outer shells.
- 11 J is an aqueous solution.
On addition of aqueous sodium hydroxide to J a green precipitate is formed.
The resulting mixture is heated and no gas is formed.
Aluminium foil is added to the warmed mixture. A gas is formed that turns damp red litmus paper blue.
Which ions could be present in J?
- A Fe^{3+} and NH_4^+
 B Fe^{3+} and NO_3^-
 C Fe^{2+} and NH_4^+
 D Fe^{2+} and NO_3^-
- 12 An aqueous solution of zinc chloride is tested by adding reagents.
Which observation is **correct**?

	reagent added to zinc chloride (aq)	observations
A	acidified aqueous barium nitrate	forms a white precipitate
B	aqueous ammonia	forms a white precipitate, soluble in excess of the reagent
C	aqueous sodium hydroxide	forms a white precipitate, insoluble in excess of the reagent
D	powdered copper	forms a grey precipitate

- 13 Which reaction is a redox reaction?
- A $\text{Mg} + 2\text{HCl} \rightarrow \text{MgCl}_2 + \text{H}_2$
 B $\text{MgCO}_3 + 2\text{HCl} \rightarrow \text{MgCl}_2 + \text{H}_2\text{O} + \text{CO}_2$
 C $\text{MgO} + 2\text{HCl} \rightarrow \text{MgCl}_2 + \text{H}_2\text{O}$
 D $\text{Mg}(\text{OH})_2 + 2\text{HCl} \rightarrow \text{MgCl}_2 + 2\text{H}_2\text{O}$
- 14 One mole of an organic compound, **Q**, is completely burnt in oxygen and produces exactly three moles of water. Which compound is **Q**?
- A butane, C_4H_{10}
 B ethanol, $\text{C}_2\text{H}_5\text{OH}$
 C propane, C_3H_8
 D propanol, $\text{C}_3\text{H}_7\text{OH}$

- 15 The diagram below shows the structure of an alloy.

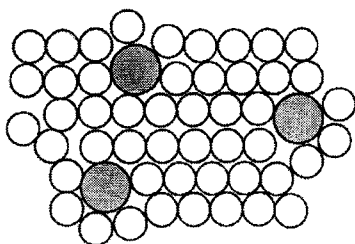

Which statement about alloys is **correct**?

- A** The alloy brass has a chemical formula.
B High carbon steel alloys are soft and easily shaped.
C Alloys can only be formed by mixing copper or iron with other metals.
D In an alloy there is attraction between positive ions and a 'sea of electrons'.
- 16 Calcium carbonate, CaCO_3 , reacts with an acid, HA as shown below.
- $$\text{CaCO}_3(\text{s}) + 2\text{HA}(\text{aq}) \rightarrow \text{CaA}_2(\text{aq}) + \text{H}_2\text{O}(\text{l}) + \text{CO}_2(\text{g})$$
- What is the minimum mass of acid required to react completely with 10 g of calcium carbonate?
 [Mr: HA, 46; CaCO_3 , 100]
- A** 4.6 g
B 9.2 g
C 10 g
D 20 g
- 17 When concentrated sulfuric acid reacts with sodium iodide the products include sulfur, iodine, hydrogen sulfide and sulfur dioxide.
 Which statement is **correct**?
- A** Hydrogen sulfide is the product of a reduction reaction.
B Iodide ions are stronger oxidising agents than sulfate ions.
C Sulfur atoms from the sulfuric acid are both oxidised and reduced.
D Sulfur atoms from the sulfuric acid are oxidised to make sulfur dioxide.
- 18 Attaching pieces of magnesium to underground iron pipes can protect the iron from corrosion.
 Which reaction protects the iron from corrosion?
- A** $\text{Fe}^{2+}(\text{aq}) + 2\text{e}^- \rightarrow \text{Fe}(\text{s})$
B $\text{Fe}(\text{s}) \rightarrow \text{Fe}^{2+}(\text{aq}) + 2\text{e}^-$
C $\text{Mg}^{2+}(\text{aq}) + 2\text{e}^- \rightarrow \text{Mg}(\text{s})$
D $\text{Mg}(\text{s}) \rightarrow \text{Mg}^{2+}(\text{aq}) + 2\text{e}^-$

- 19 The names and formulae of three nitrogen compounds are shown below.

ammonia	hydrazine	hydroxylamine
NH_3	N_2H_4	NH_2OH

Which compound has the highest relative molecular mass, M_r , and in which compound is the percentage by mass of hydrogen the **greatest**?

	highest M_r	greatest percentage by mass of hydrogen
A	N_2H_4	NH_3
B	N_2H_4	N_2H_4
C	NH_2OH	NH_3
D	NH_2OH	N_2H_4

- 20 In an experiment, 1 mol of powdered copper and 1 mol of powdered zinc are placed in a flask. Dilute acid, containing 1 mol of acid, is added to the flask. The flask is left until all the reactions, if any, are complete. Which diagram shows the result of the experiment?

A

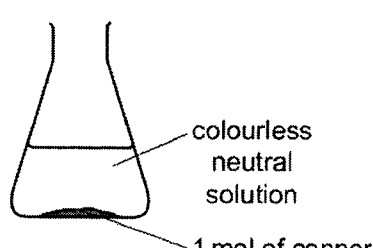

colourless neutral solution
1 mol of copper

B

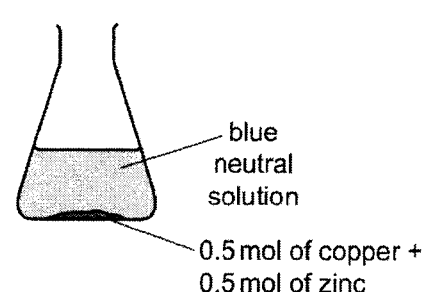

blue neutral solution
0.5 mol of copper + 0.5 mol of zinc

C

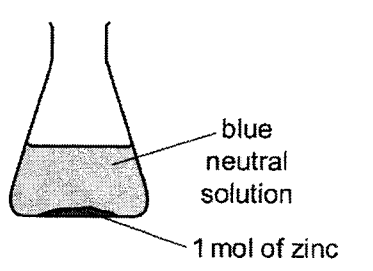

blue neutral solution
1 mol of zinc

D

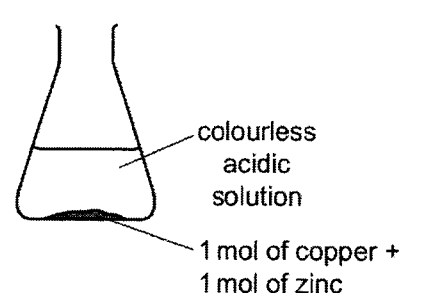

colourless acidic solution
1 mol of copper + 1 mol of zinc

- 24 CFC compounds were used as aerosol propellants. The structure of one CFC compound is shown.

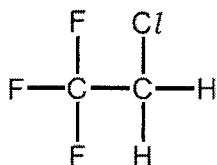

Which element in this compound causes a depletion of ozone in the atmosphere?

- A carbon
 B chlorine
 C fluorine
 D hydrogen
- 25 Pollutant gases are released by the bacterial decay of vegetable matter. The bacterial decay of vegetable matter is the main source of which gas?
- A carbon monoxide
 B methane
 C nitrogen dioxide
 D sulfur dioxide
- 26 The rate of a chemical reaction decreases as the temperature decreases because at a lower temperature:
- 1 a lower proportion of molecules have energy that exceeds the activation energy
 - 2 the molecules are further apart
 - 3 the frequency of successful collision is less.
- Which reasons **correctly** explain this decrease?
- A 1 and 2 only
 B 1 and 3 only
 C 2 and 3 only
 D 1, 2 and 3
- 27 If a sample of ammonia is passed over heated iron, two gases, X and Y, are formed. Gas X reacts with oxygen. Gas Y is unreactive. Which statement is **correct**?
- A Gas X reacts with oxygen to form water.
 B Gas Y is a compound.
 C The formation of the two gases from ammonia cannot be reversed.
 D There is a triple covalent bond in one molecule of gas X.

- 28 The rate of the reaction between a metal carbonate and a dilute acid is followed by measuring the volume of carbon dioxide produced and plotting this against time.

The line labelled X shows the results of an experiment using 50 cm³ of 1.0 mol / dm³ hydrochloric acid and excess metal carbonate.

The experiment is repeated using different conditions and lines Y and Z are drawn to show the volumes of carbon dioxide produced against time.

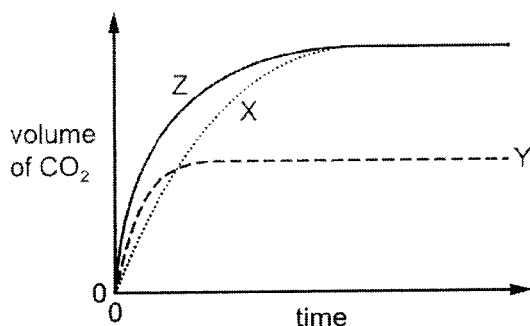

Which row shows the conditions that could give lines Y and Z?

	conditions for Y	conditions for Z
A	50 cm ³ of 0.5 mol / dm ³ hydrochloric acid at same temperature.	25 cm ³ of 2.0 mol / dm ³ hydrochloric acid at same temperature
B	50 cm ³ of 0.5 mol / dm ³ hydrochloric acid at same temperature with a catalyst.	12.5 cm ³ of 4.0 mol / dm ³ hydrochloric acid at same temperature.
C	50 cm ³ of 1.0 mol / dm ³ hydrochloric acid at a lower temperature.	50 cm ³ of 1.0 mol / dm ³ hydrochloric acid at a higher temperature.
D	50 cm ³ of 0.5 mol / dm ³ hydrochloric acid at a higher temperature.	50 cm ³ of 1.0 mol / dm ³ sulfuric acid at same temperature.

- 29 Magnesium can be produced by electrolysis of molten magnesium chloride, MgCl₂. What are the equations for the reactions that occur at the positive electrode and at the negative electrode?

	positive electrode	negative electrode
A	$2Cl^- \rightarrow Cl_2 + 2e^-$	$2H^+ + 2e^- \rightarrow H_2$
B	$Cl_2 + 2e^- \rightarrow 2Cl^-$	$Mg^{2+} + 2e^- \rightarrow Mg$
C	$2Cl^- \rightarrow Cl_2 + 2e^-$	$Mg^{2+} + 2e^- \rightarrow Mg$
D	$2Cl^- \rightarrow Cl_2 + 2e^-$	$Mg^{2+} + 2e^- \rightarrow 2Mg$

- 30 The diagram below shows the electrolysis of concentrated and dilute aqueous sodium chloride using inert electrodes. Gases are produced and collected in each of the test-tubes W, X, Y and Z.

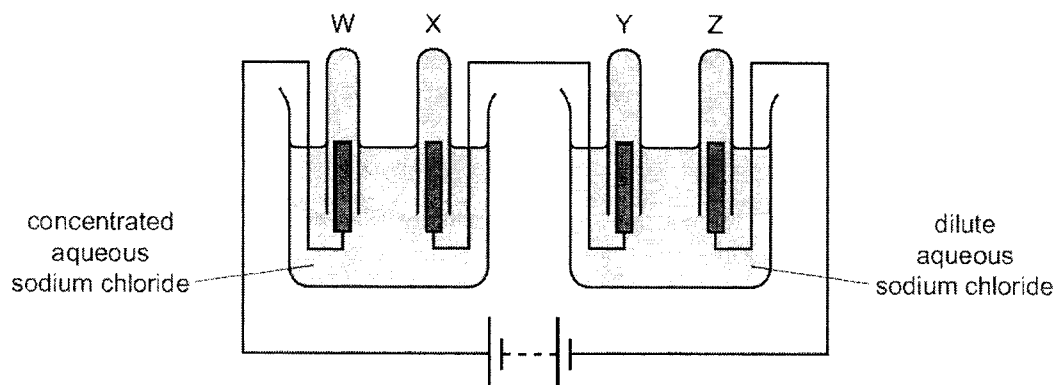

Which statements are **correct**?

- 1 Approximately equal volumes of gas are produced and collected in test-tubes W and X.
- 2 Approximately equal volumes of gas are produced and collected in test-tubes Y and Z.
- 3 Three different gases are produced in the experiment.

- A** 1, 2 and 3
B 1 and 2 only
C 2 and 3 only
D 1 and 3 only

- 31 The apparatus shown below is set up to plate a steel key with copper.

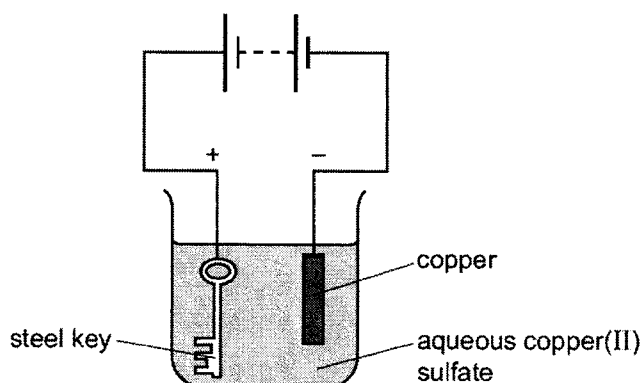

The key does not get coated with copper.
 Which change needs to be made to plate the key?

- A** Increase the voltage.
B Reverse the electrical connections.
C Replace the solution with dilute sulfuric acid.
D Increase the concentration of the aqueous copper (II) sulfate.

- 32 A hydrocarbon, C_xH_y , undergoes an addition reaction with chlorine.
A second hydrocarbon, C_pH_q , undergoes a substitution reaction with chlorine.
If $x = 4$ and $p = 6$, what are the values of y and q ?

	y	q
A	8	16
B	8	14
C	10	12
D	10	14

- 33 Compound X is shown in the dot-and-cross diagram below.

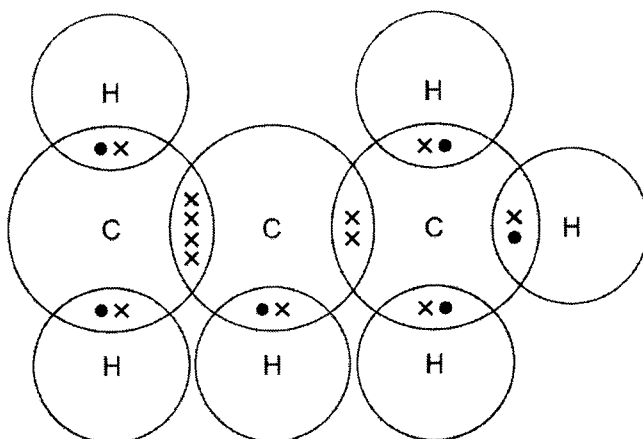

Which statement about compound X is **correct**?

- A It is a saturated hydrocarbon.
B It is an isomer of butene.
C It will decolourise bromine water.
D Its chemical name is propane.
- 34 A solution of sodium hydroxide reacts with 3 mol of chlorine under certain conditions. The reaction produces 5 mol of sodium chloride and 1 mol of X, the only other chlorine-containing product. What is the formula of compound X?
- A $NaClO$
B $NaClO_2$
C $NaClO_3$
D $NaClO_4$
- 35 An ester is formed from a carboxylic acid and an alcohol.
How does the number of carbon, hydrogen and oxygen atoms in an ester differ from the total number of these atoms in the carboxylic acid and alcohol from which the ester is formed?

	carbon atoms	hydrogen atoms	oxygen atoms
A	fewer	fewer	fewer
B	fewer	same	fewer
C	same	fewer	fewer
D	same	same	same

- 38 A carboxylic acid with molecular formula $C_4H_8O_2$ reacts with an alcohol with molecular formula C_3H_8O to form an ester. What is the formula of the ester formed?

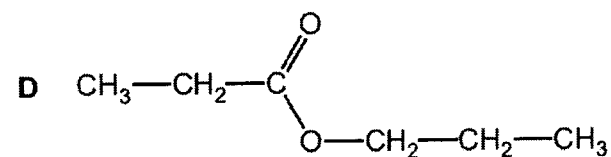
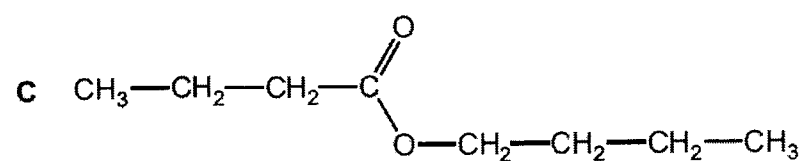
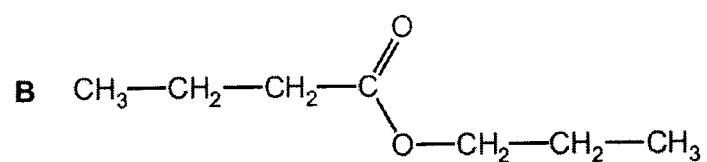
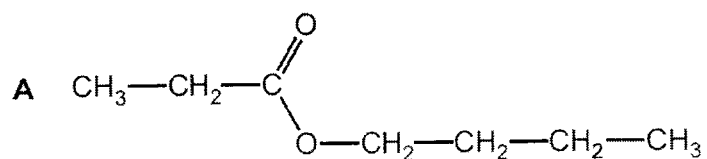

- 39 Chlorine reacts with ethane to produce chloroethane and hydrogen chloride. The reaction is exothermic.



The bond energies are shown in the table.

bond	bond energy in kJ/mol
C-Cl	+340
C-C	+350
C-H	+410
Cl-Cl	+240
H-Cl	+430

What is the energy change for the reaction?

- A -1420 kJ / mol
- B -120 kJ / mol
- C +120 kJ / mol
- D +1420 kJ / mol

40 The diagram below shows the repeat unit of a polymer.

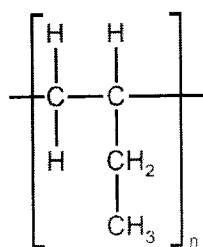

Which row **correctly** identifies the monomer and type of polymerisation involved in making this polymer?

	monomer	type of polymerisation
A	$\begin{array}{cc} \text{H} & \text{H} \\ & \\ \text{C} & =\text{C} \\ & \\ \text{H} & \text{C}_2\text{H}_5 \end{array}$	addition
B	$\begin{array}{cc} \text{H} & \text{H} \\ & \\ \text{C} & =\text{C} \\ & \\ \text{H} & \text{C}_2\text{H}_5 \end{array}$	condensation
C	$\begin{array}{cc} \text{H} & \text{H} \\ & \\ \text{H}-\text{C} & -\text{C} \\ & \\ \text{H} & \text{CH} \\ & \\ & \text{CH}_3 \end{array}$	addition
D	$\begin{array}{cc} \text{H} & \text{H} \\ & \\ \text{H}-\text{C} & -\text{C} \\ & \\ \text{H} & \text{CH} \\ & \\ & \text{CH}_3 \end{array}$	condensation

End of Paper

Setter: Ms Kim



GUANGYANG SECONDARY SCHOOL
PRELIMINARY EXAMINATION 2022
 Secondary Four Express

CANDIDATE
NAME

CENTRE
NUMBER

INDEX
NUMBER

CLASS/
REG No.

 /

CHEMISTRY

Paper 2

6092/02

23 August 2022

1 hour 45 mins

Additional Materials: Periodic Table

READ THESE INSTRUCTIONS FIRST

Write your name, centre number, index number, class and register number in the spaces above.

Write in dark blue or black ink.

You may use a pencil for any diagrams or graphs.

Do not use staples, paper clips, highlighters, glue or correction fluid.

Section A

This section consists of **seven** questions. Answer **all** questions in the spaces provided.

Section B

This section consists of **three** questions. Answer **all three** questions, the last question is in the form either/or.

Write your answers in the spaces provided.

The number of marks is given in brackets [] at the end of each question or part question.

A copy of the data sheet and Periodic Table will be provided.

The use of an approved scientific calculator is expected, where appropriate.

For Examiner's Use	
Section A	
B8	
B9	
B10	
Total	

This question paper consists of 18 printed pages, inclusive of this cover page

SECTION A (50 marks): This section consists of seven structured questions. Answer all questions in the spaces provided.

A1 (a) The following table gives information about six substances.

substance	melting point / °C	boiling point / °C	electrical conductivity as a solid	electrical conductivity as a liquid
A	839	1484	good	good
B	-188	-42	poor	poor
C	776	1497	poor	good
D	-117	78	poor	poor
E	1607	2227	poor	poor
F	-5	102	poor	good

(i) Which substance could be a metal?

..... [1]

(ii) State all the substances that are liquid at room temperature.

..... [1]

(iii) Which substance could have a macromolecular structure similar to that of silicon (IV) oxide?

..... [1]

(iv) Which substance could be sodium chloride?

..... [1]

(b) The symbol equation for the production of sodium hydride is shown below.

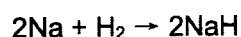

(i) Suggest why the hydrogen must be dry.

..... [1]

(ii) Sodium hydride reacts with iron (III) oxide to form iron and sodium hydroxide. Write a balanced chemical equation for the reaction.

..... [1]

- (iii) Explain, in terms of electron transfer, how this equation shows that it is a redox reaction.

.....

.....

.....

.....

[3]

[Total: 9]

- A2 The polymer known as PVA is used in paints and adhesives. Its structural formula is shown below.

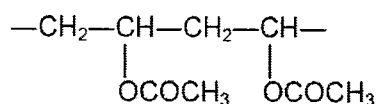

- (a) Deduce the structural formula of its monomer.

[1]

- (b) A condensation polymer can be made from the following monomers.

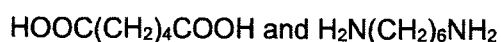

Draw the structural formula of this polymer, showing two repeating units.

[2]

- (c) Besides fractional distillation of petroleum, some fractions can be obtained through cracking. More petrol can be made by cracking less useful petroleum fractions. Write a chemical equation for the cracking of dodecane, $\text{C}_{12}\text{H}_{26}$, to form ethene and one other hydrocarbon.

.....

[1]

[Total: 4]

- A3 Mixtures can be separated by physical processes.
The boiling points of four different alcohols, **A**, **B**, **C** and **D**, are shown below.

alcohol	A	B	C	D
boiling point / °C	56	78	122	160

A student suggested that the apparatus shown below could be used to separate the mixture of alcohols.

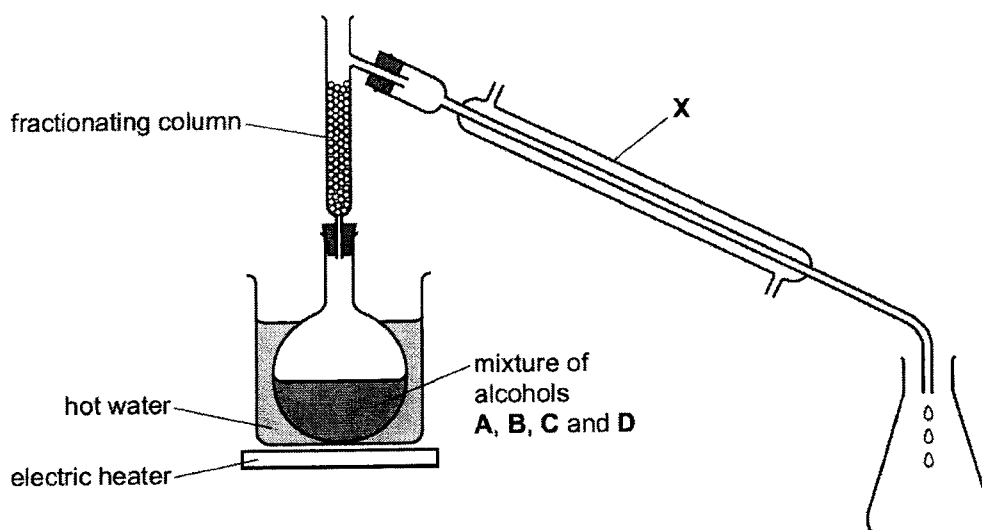

- (a) Apparatus **X** needs to have cold water flowing through it.

- Draw an arrow on the diagram to show where the cold water enters apparatus **X**. [1]
- Name apparatus **X**. [1]

..... [1]

- (b) Part of the fractionating column is missing. This means that the experiment will not work.

- Draw on the diagram the part of the fractionating column which is missing. [1]
- Explain why the experiment will not work with this part of the fractionating column missing. [1]

..... [1]

..... [1]

- (c) Suggest why a Bunsen burner is **not** used to heat the flask.

..... [1]

(d) A hot water bath cannot be used to separate alcohols **C** and **D**. Explain why.

.....

.....

.....

[Total: 6]

[1]

A4 (a) The alcohols form a homologous series.
The following two alcohols are members of a homologous series and they are isomers.

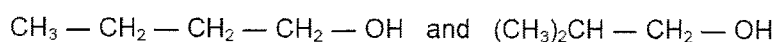

(i) Explain why they are isomers.

.....

.....

.....

[2]

(ii) Deduce the structural formula of another alcohol which is also an isomer of these alcohols.

[1]

(b) Copper (II) oxide can oxidise butanol to liquid **X**, whose pH is 4.

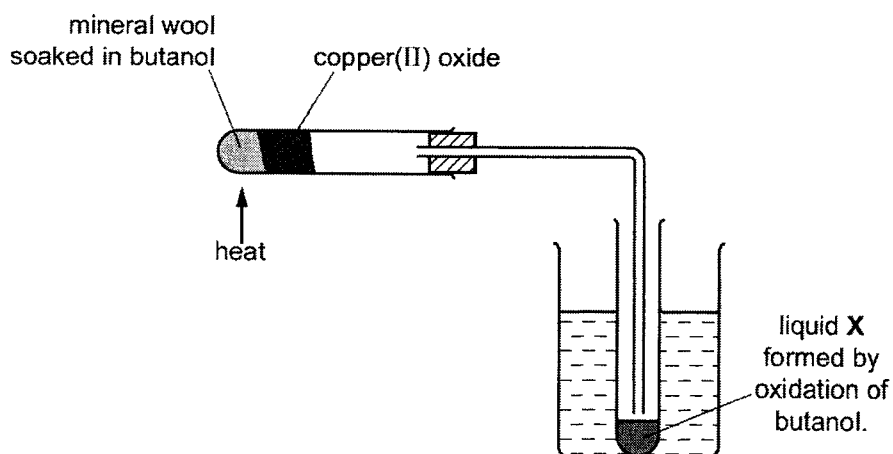

(i) Give the name of another reagent which can oxidise butanol.

.....

[1]

(ii) Which homologous series does liquid **X** belong to?

..... [1]

(iii) State the formula of liquid **X**.

..... [1]

(c) The alcohol ethanol can be made by fermentation. Yeast is added to aqueous glucose.

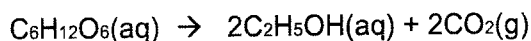

Carbon dioxide is given off and the mixture becomes warm, as the reaction is exothermic.

The graph shows how the rate of reaction varies over several days.

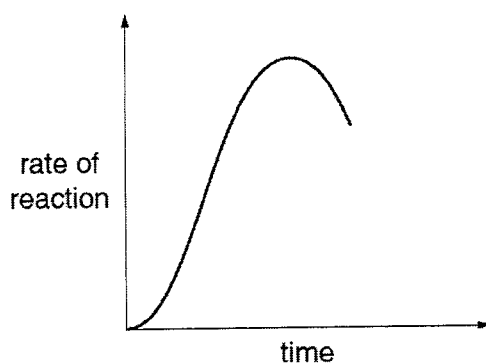

(i) Suggest a method of measuring the rate of this reaction.

..... [1]

(ii) Why does the rate initially increase?

..... [1]

(iii) Suggest one reason why the rate eventually decreases.

..... [1]

[Total: 9]

A5 Hydrogen reacts with oxygen as shown in the equation.

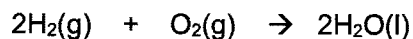

A sample containing 1.00 mol of hydrogen, H_2 , is completely burnt.
This sample releases 286 kJ of heat energy.

(a) Calculate the heat energy released when 25.0 g of hydrogen is completely burnt. [2]

(b) Use ideas about bond breaking and bond forming to explain why this reaction is exothermic.

.....

[2]

(c) The reaction shown also represents the overall process that occurs within a hydrogen-oxygen fuel cell.

(i) Describe one advantage of using a hydrogen-oxygen fuel cell to power a motor vehicle rather than burning petrol.

.....

[1]

(ii) Complete the equations for the two electrode reactions that happen in a hydrogen-oxygen fuel cell.



[2]

[Total: 7]

A6 Sulfur dioxide is a colourless gas which can be found in air.

- (a) State one environmental problem caused by the presence of sulfur dioxide in air.

.....
.....

[1]

- (b) When heated in air, iron pyrite, FeS_2 , reacts with oxygen. Sulfur dioxide and iron (III) oxide, Fe_2O_3 , are the products of this reaction. Write the equation for this reaction.

.....

[1]

- (c) Explain, in terms of oxidation state, if the reaction in (b) is a redox reaction.

.....
.....
.....

[3]

- (d) Liquid sulfur dioxide is stored in cylinders. When the cylinder is opened the liquid quickly changes into a gas. Use the kinetic particle theory to describe the changes in **movement** and **arrangement** of the particles when liquid sulfur dioxide becomes a gas.

.....
.....
.....
.....
.....

[2]

[Total: 7]

A7 A student carries out an electrolysis experiment using the apparatus shown below.

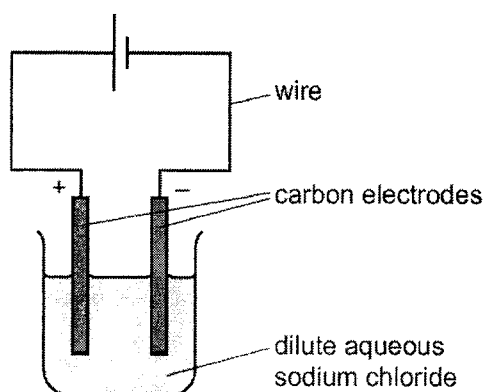

The student uses dilute aqueous sodium chloride.

(a) State the name given to any solution which undergoes electrolysis.

..... [1]

(b) (i) Hydroxide ions are discharged at the anode. Write the ionic half-equation for the anode.

..... [1]

(ii) Explain how the ionic half-equation shows the hydroxide ions are being oxidised.

..... [1]

(c) (i) Describe what the student observes at the cathode.

..... [1]

(ii) Write the ionic half-equation for the reaction at the cathode.

..... [1]

(d) The student repeats the experiment using concentrated aqueous sodium chloride. Describe what the student observes at:

• the cathode [1]

• the anode [1]

(e) Write the overall chemical equation for (d).

..... [1]

[Total: 8]

End of Section A

SECTION B (30 marks)

Answer all three questions in the spaces provided. The last question is in the form of an either/or and only one of the alternatives should be attempted.

- B8 A student uses the apparatus shown to investigate the reaction between marble (CaCO_3) and hydrochloric acid. 10.0 g of marble lumps (an excess) are added to 30.0 cm^3 of 1.20 mol / dm^3 hydrochloric acid contained in a flask. The mass of the flask and contents is recorded every 30 seconds. This is experiment 1. The experiment is repeated using the same mass of marble but finely powdered instead of lumps. The volume and concentration of the hydrochloric acid used is unchanged. This is experiment 2.

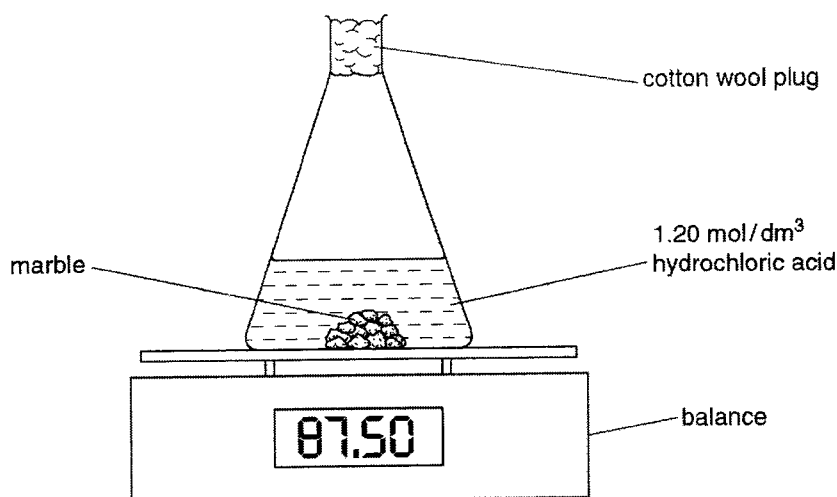

- (a) The results of the two experiments are recorded in the table. Complete the table by calculating the total change in mass at each time for both experiments. [2]

time / s	experiment 1 (lumps)		experiment 2 (powder)	
	mass of flask and contents / g	total change in mass / g	mass of flask and contents / g	total change in mass / g
0	87.50	0.00	87.50	0.00
30	87.22	0.28	87.02	0.48
60	87.02	0.48	86.83	0.67
90	86.87		86.74	
120	86.77		86.69	
150	86.69		86.69	
180	86.69		86.69	

- (b) Construct the equation for the reaction between calcium carbonate and hydrochloric acid. [1]
-

- (c) Suggest why the mass of the flask and contents decreases as the reaction progresses.

..... [1]

- (d) Plot the points for each experiment on the grid.
Draw a smooth curve through each set of points.
Label the curves 'experiment 1' and 'experiment 2'.

[3]

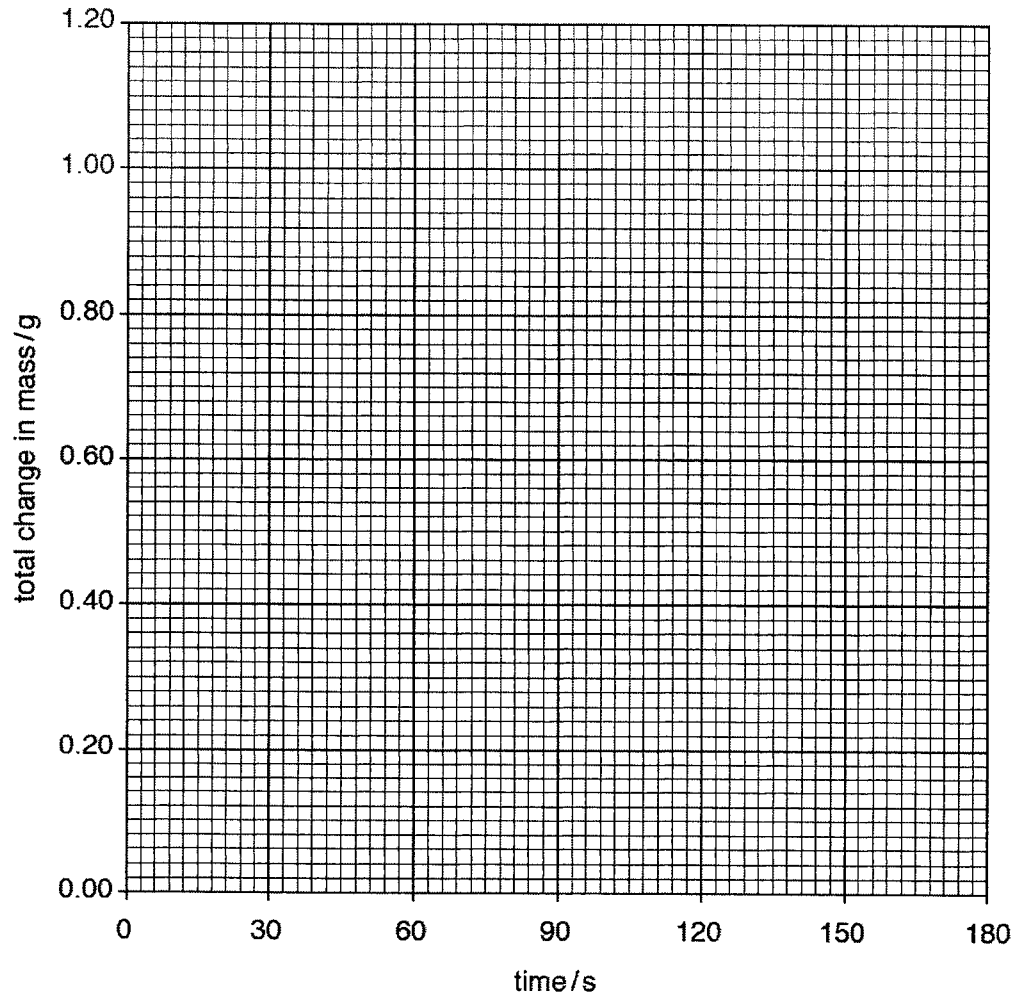

Using your graph,

- (i) what is the total change in mass in experiment 1 after 75 seconds,

..... [1]

- (ii) what is the mass of the flask and contents in experiment 2 after 45 seconds?

..... [1]

- (f) Using your equation in (b), calculate the mass of marble that remains after reaction with 30 cm³ of 1.20 mol / dm³ hydrochloric acid. [3]

[Total: 12]

- B9 (a) Steel may be coated with another metal, e.g. zinc or chromium, or with a polymer, e.g. poly(chloroethene), to prevent rusting.

(i) Suggest a property of poly(chloroethene) that makes it suitable for this purpose.

..... [1]

(ii) Explain why the steel will rust when the protective coating of chromium or polymer is broken.

.....
 [1]

(iii) When the protective layer of zinc is broken, the steel does not rust. Suggest an explanation.

.....

 [2]

- (b) A student investigated simple cells using the apparatus shown below.

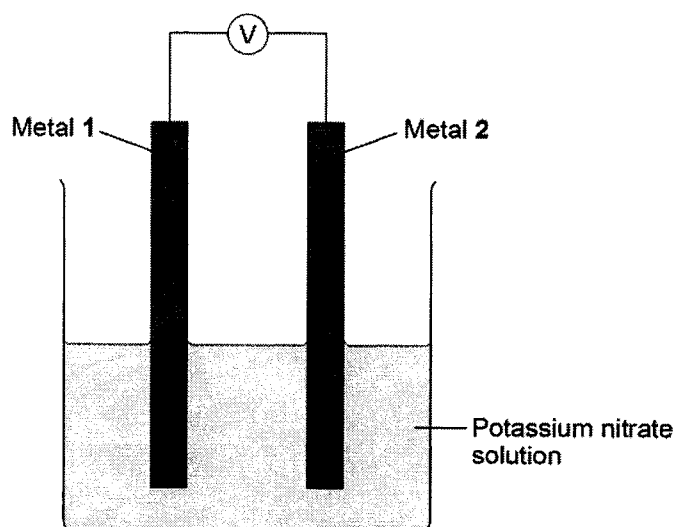

- If metal 2 is more reactive than metal 1 then the voltage measured is positive.
- If metal 1 is more reactive than metal 2 then the voltage measured is negative.
- The bigger the difference in reactivity of the two metals, the larger the voltage produced.

The student's results are shown in the table below.

Metal 2 Metal 1	Chromium	Copper	Iron	Tin	Zinc
Chromium	0.0 V				
Copper	1.2 V	0.0 V			
Iron	0.5 V	not measured	0.0 V		
Tin	0.8 V	-0.4 V	0.3 V	0.0 V	
Zinc	0.2 V	-1.0 V	-0.3 V	-0.6 V	0.0 V

- (i) The ionic equation for the reaction occurring at the zinc electrode in the simple cell made using copper and zinc electrodes is:

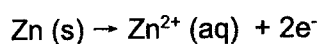

Zinc is oxidised in this reaction.
Give a reason why this is oxidation.

..... [1]

- (ii) Which one of the metals used was the least reactive?
Give a reason for your answer.

..... [1]

- (iii) Predict the voltage that would be obtained for a simple cell that has iron as metal 1 and copper as metal 2.
Explain your answer.

..... [2]

[Total: 8]

Either

B10 (a) Nitrogen reacts with fluorine to form nitrogen trifluoride, NF_3 .

(i) The chemical equation can be represented as shown below.

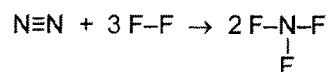

Some bond energies are shown in the table.

bond	bond energy in kJ/mol
$\text{N}\equiv\text{N}$	945
$\text{F}-\text{F}$	160
$\text{N}-\text{F}$	300

Calculate the energy change for the reaction between nitrogen and fluorine.

[3]

(ii) Use your answer to (i) to deduce whether this reaction is endothermic or exothermic. Explain your answer.

.....

[1]

(b) Draw a dot-and-cross diagram to show the arrangement of all the electrons in one molecule of nitrogen trifluoride.

[2]

- (c) (i) Silver nitrate can be prepared by reacting silver oxide with dilute nitric acid as shown below.



Excess silver oxide is reacted with 30.0 cm³ of 0.150 mol/dm³ nitric acid.
After purification the percentage yield of silver nitrate is 80.0 %.
Calculate the mass of silver nitrate prepared.

[3]

- (ii) Explain why excess silver oxide is used in the preparation of silver nitrate in (i).

..... [1]

[Total: 10]

Or

- B10 (a) Silicon shows the same type of bonding and structure as diamond. Silicon reacts with magnesium to form Mg_2Si . Solid Mg_2Si reacts with dilute hydrochloric acid to form gaseous SiH_4 and a solution of magnesium chloride.

(i) Construct an equation for this reaction. Include state symbols.

..... [2]

(ii) Predict the shape of the SiH_4 molecule.

..... [1]

- (b) Calcium chlorate (I), $Ca(ClO)_2$, is used as an alternative to sodium chlorate (I), $NaClO$, in some household products.

(i) The chlorate (I) ion is formed when cold aqueous sodium hydroxide reacts with chlorine. Write an ionic equation for this reaction.

..... [1]

(ii) The chlorate(I) ion is unstable and decomposes when heated as shown.

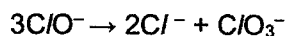

This reaction can be described as a disproportionation reaction. Describe what is meant by disproportionation reaction.

..... [1]

(iii) Explain, in terms of oxidation state, if the disproportion reaction is a redox reaction.

..... [2]

- (c) Phosphorus is a non-metal in Group V of the Periodic Table. Phosphorus can be manufactured from calcium phosphate, $\text{Ca}_3(\text{PO}_4)_2$ as shown below.

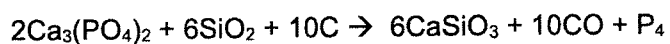

What is the maximum mass of phosphorus that can be made using 300 g of silicon dioxide, SiO_2 ?

[3]

[Total: 10]

End of Paper

Setter: Ms Kim

4E Chemistry Prelim Exam 2022
Answers

Paper 1

1	D	2	D	3	C	4	C	5	D
6	D	7	C	8	C	9	C	10	B
11	D	12	B	13	A	14	B	15	D
16	B	17	A	18	D	19	C	20	A
21	B	22	D	23	B	24	B	25	B
26	B	27	A	28	B	29	C	30	D
31	B	32	B	33	C	34	C	35	C
36	A	37	C	38	B	39	B	40	A

Paper 2

SECTION A

- A1 (a)
- (i) A [1]
 - (ii) D / F [1]
 - (iii) E [1]
 - (iv) C [1]
- (b)
- (i) If moist, hydrogen will react explosively with sodium. [1]
 - (ii) $\text{Fe}_2\text{O}_3 + 3\text{NaH} \rightarrow 2\text{Fe} + 3\text{NaOH}$ [1]
 - (iii) Fe_2O_3 is reduced to Fe because Fe^{3+} (in Fe_2O_3) gained electrons to form Fe. [3]
NaH is oxidised to NaOH because H^- (in NaH) lost electrons to form H^+ (in NaOH).

[Total: 9]

- A2 (a) [1]

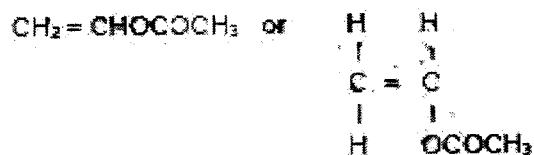

- (b) [2]
- $$\begin{array}{cccccccc} \text{O} & & \text{O} & & \text{O} & & \text{O} & \\ || & & || & & || & & || & \\ -\text{C}- & (\text{CH}_2)_4- & \text{C}- & \text{N}- & (\text{CH}_2)_6- & \text{N}- & \text{C}- & (\text{CH}_2)_4- & \text{C}- & \text{N}- & (\text{CH}_2)_6- & \text{N}- \\ & & & | & & | & & | & & | & & | \\ & & & \text{H} & & \text{H} & & \text{H} & & \text{H} & & \text{H} \end{array}$$

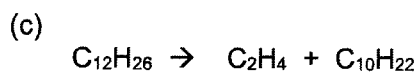

OR



[1]

[Total: 4]

A3

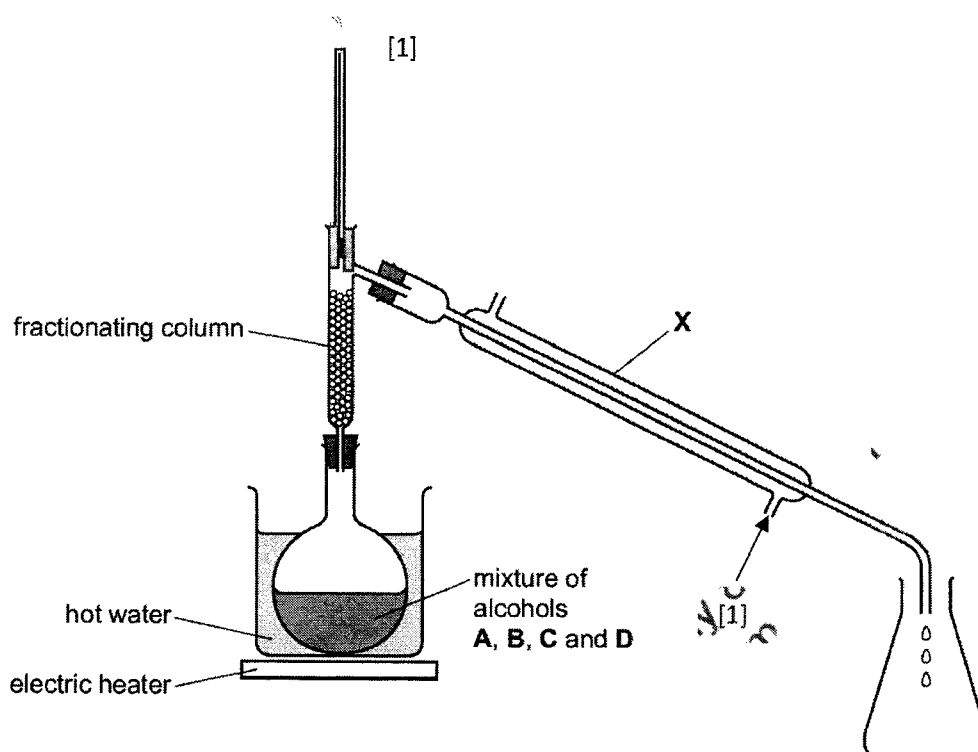

- (a) Liebig condenser [1]
- (b) Alcohols will evaporate through and will not distil off at any specific temperatures. [1]
- (c) Alcohols are flammable. [1]
- (d) Water will boil first before the alcohols can boil because they have higher boiling points and the alcohols will not be separated out. [1]

[Total: 6]

- A4 (a) (i) They have the same molecular formula but different structural formula. [2]



- (b) (i) Acidified potassium manganate (VII) oxygen [1]
- (ii) carboxylic acid [1]
- (iii) C_3H_7COOH [1]

- (c) (i) Measure the volume of gas produced over regular time intervals [1]
 (ii) There was an increase in temperature. [1]
 (iii) Glucose was used up. [1]

[Total: 9]

- A5 (a) 1 mol of $H_2 = 2(1) = 2g$ [2]
 No. of mol of $H_2 = \frac{25}{2} = 12.5$

$$\text{Heat Energy released} = 12.5 \times 286 = 3575 \text{ kJ}$$

- (b) The amount of energy given out to make bonds in 2 mols of water is greater than the amount of energy taken in to make bonds in 2 mol of hydrogen and one mol of oxygen. [2]
- (c) (i) Advantage of using hydrogen-oxygen fuel is that it does not produce any pollutants (produces water) but petrol may produce carbon monoxide or carbon. [1]
 (ii) $H_2 \rightarrow \dots\dots\dots 2H^+ \dots\dots\dots + 2e^-$
 $O_2 + 4H^+ + 4e^- \rightarrow \dots\dots 2H_2O \dots\dots\dots$ [2]

[Total: 7]

- A6 (a) Sulfur dioxide reacts with the rain to form acid rain that destroys crops and buildings. [1]
 (b) $4FeS_2 + 11O_2 \rightarrow 2Fe_2O_3 + 8SO_2$ [1]
 (c) FeS_2 is oxidized to Fe_2O_3 because oxidation state of iron increase from +2 to +3. O_2 is reduced to Fe_2O_3 and SO_2 because the oxidation state of oxygen decrease from 0 to -2 in Fe_2O_3 and SO_2 . FeS_2 is also oxidised to SO_2 because the oxidation state of sulfur increase from -1 to +4. [3]
 (d) Liquid sulfur dioxide molecules are arranged closely packed together in a disorderly arrangement sliding over each other under high pressure in the cylinders. When the pressure in the cylinders is reduced when the cylinders are opened, liquid molecules move further apart in all directions with a lot of empty space between them when they are in the gaseous state. [2]

[Total: 7]

- A7 (a) electrolyte [1]
 (b) (i) $4OH^-(aq) \rightarrow 2H_2O(l) + O_2(g) + 4e^-$ [1]
 (ii) OH^- ions loses electrons to form water and oxygen. [1]

- (c) (i) Effervescence of a colourless gas seen. [1]
- (ii) $2\text{H}^+(\text{aq}) + 2\text{e}^- \rightarrow \text{H}_2(\text{g})$ [1]
- (d)
- the cathode : effervescence of a colorless gas seen [1]
 - the anode : effervescence of a yellow green gas produced [1]
- (e) $2\text{NaCl}(\text{aq}) + \text{H}_2\text{O}(\text{l}) \rightarrow 2\text{NaOH}(\text{aq}) + \text{Cl}_2(\text{g}) + \text{H}_2(\text{g})$ [1]
- [Total: 8]

End of Section A

SECTION B (30 marks)

B8 (a)

time / s	experiment 1 (lumps)		experiment 2 (powder)	
	mass of flask and contents / g	total change in mass / g	mass of flask and contents / g	total change in mass / g
0	87.50	0.00	87.50	0.00
30	87.22	0.28	87.02	0.48
60	87.02	0.48	86.83	0.67
90	86.87	0.63	86.74	0.76
120	86.77	0.73	86.69	0.81
150	86.69	0.81	86.69	0.81
180	86.69	0.81	86.69	0.81

- (b) $\text{CaCO}_3 + 2\text{HCl} \rightarrow \text{CaCl}_2 + \text{CO}_2 + \text{H}_2\text{O}$ [1]
- (c) The production of carbon dioxide gas which escapes into the air. [1]

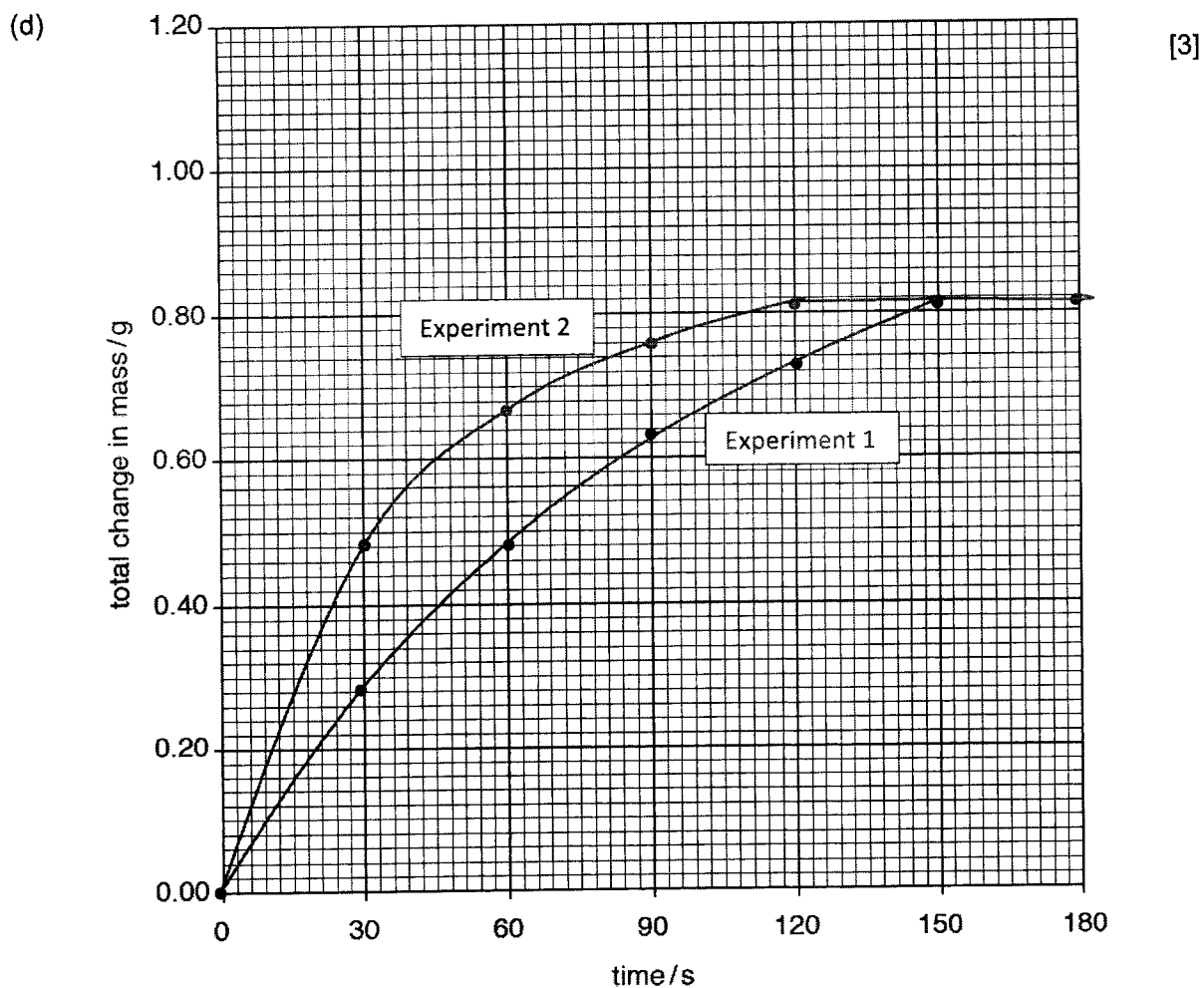

(i) 0.56 g [1]

(ii) $87.50 - 0.56 = 86.92$ g [1]

(f) No. of mol of HCl = $0.0300 \times 1.20 = 0.0360$ [3]

$$\frac{\text{No. of mol. of CaCO}_3}{\text{No. of mol. of HCl}} = \frac{1}{2}$$

$$\text{No. of mol of CaCO}_3 = \frac{1}{2} \times 0.0360 = 0.0180$$

$$\text{Mass of CaCO}_3 \text{ used} = 0.0180 \times (40 + 12 + 3(16)) = 1.80 \text{ g}$$

$$\text{Mass of CaCO}_3 \text{ remains} = 10.0 - 1.80 = 8.2 \text{ g}$$

[Total: 12]

- B9 (a) (i) Poly(chloroethene) is inert and corrosion resistant. [1]
 (ii) Iron in steel will be exposed to the air and water and hence, will rust. [1]
 (iii) Zinc is more reactive than iron and will undergo sacrificial protection and will corrode in place of iron; hence, preventing from rusting. [2]
- (b) (i) Zinc lost electrons to form Zn^{2+} [1]
 (ii) Copper. It sets up a voltage of +1.2 V (the largest) with chromium. [1]
 (iii) The voltage will be -0.7V. Since iron is more reactive than copper and as metal 1, the voltage will be negative. Since the voltage between zinc and copper is 1 V; the voltage between zinc and iron is 0.3 V; hence, the voltage between iron and copper is 0.7 V. [2]

[Total: 8]

Either

- B10 (a) (i) Amount of energy taken in to break bonds in one mole of N_2 and 3 moles of F_2
 $= 945 + 3(160) = 1425 \text{ kJ}$
 Amount of energy given out to make bonds in 2 mols of NF_3
 $= 2(3)(300) = 1800 \text{ kJ}$
 Hence, $\Delta H = 1425 - 1800 = -375 \text{ kJ}$ [3]
- (ii) The reaction is exothermic because ΔH is negative. [1]
- (b) Draw a dot-and-cross diagram to show the arrangement of all the electrons in one molecule of nitrogen trifluoride. [2]

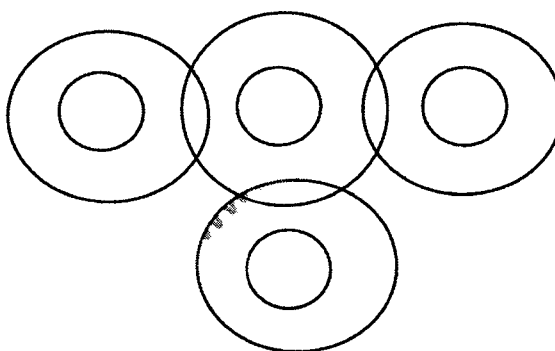

- (c) (i) No. of mol of $\text{HNO}_3 = 0.030 \times 0.150 = 0.00450$

$$\frac{\text{No. of mol of AgNO}_3}{\text{No. of mol of HNO}_3} = \frac{2}{2} = 1$$
 [3]
 No. of mol of $\text{AgNO}_3 = 0.00450$
 Mass of $\text{AgNO}_3 = 0.00450 \times (108 + 14 + 3(16))$
 $= 0.765 \text{ g}$

$$\text{Mass of AgNO}_3 \text{ produced} = \frac{80}{100} \times 0.765 = 0.612 \text{ g}$$

- (ii) To ensure that all the nitric acid is used up.

[1]
[Total: 10]

Or

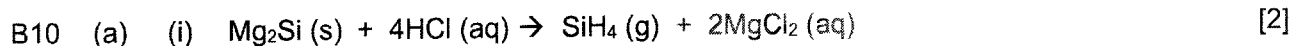

- (ii) It is tetrahedral in shape. [1]

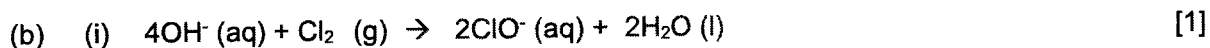

- (ii) A reaction where a substance undergoes oxidation and reduction at the same time. [1]

- (iii) It is a redox reaction because ClO^- is reduced to Cl^- and ClO^- is also oxidized to ClO_3^- .
 ClO^- is reduced to Cl^- because the oxidation state of chlorine decreased from +1 to -1. ClO^- is oxidized to ClO_3^- because the oxidation state of chlorine is increased from +1 to +5. [2]

(c) No. of mol of $\text{SiO}_2 = \frac{300}{28 + 2(16)} = 5$ [3]

$$\frac{\text{No. of mol of P}_4}{\text{No. of mol of SiO}_2} = \frac{1}{6}$$

$$\text{Therefore, no. of mol of P}_4 = \frac{1}{6} \times 5 = 0.833$$

$$\begin{aligned} \text{Mass of P}_4 \text{ produced} &= 0.833 \times 4(31) = 103.3 \text{ g} \\ &= 103 \text{ g (3 sf)} \end{aligned}$$

[total: 10]

End of Paper