



AI TONG SCHOOL

**2020 END-OF-YEAR EXAMINATION
PRIMARY THREE SCIENCE**

(BOOKLET A)

29 OCTOBER 2020

Total time for booklets A and B : 1 h

INSTRUCTIONS

Do not turn over this page until you are told to do so.

Follow all instructions carefully.

Answer all questions.

Name : _____ ()

Class : Primary 3 _____

Parent's Signature : _____

Booklet A	30
Booklet B	20
Total	50

Section A (15 x 2 marks)

For each question from 1 to 15, four options are given. One of them is the correct answer. Make your choice and shade the correct oval (1, 2, 3 or 4) on the Optical Answer Sheet.

1. The pictures below show an animal before and after one year.

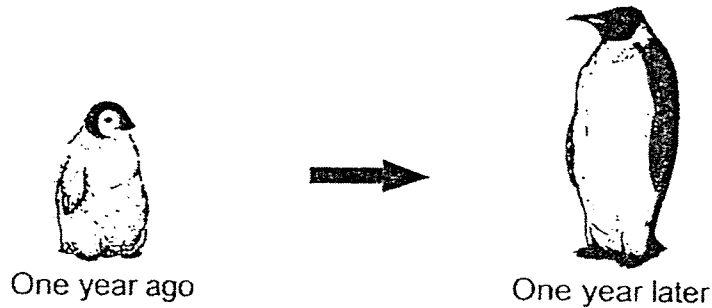

The above shows that the animal is a living thing because it can _____.

- (1) grow
 - (2) breathe
 - (3) reproduce
 - (4) respond to changes
2. The table below shows the characteristics of organisms, W, X, Y and Z. A tick (✓) shows the organism has the characteristic.

Characteristic	Organism			
	W	X	Y	Z
Reproduce from spores		✓		✓
Can only be seen under a microscope			✓	
Get their food from other living things only	✓	✓	✓	

Which of the organisms, W, X, Y or Z, is most likely a plant?

- (1) W
- (2) X
- (3) Y
- (4) Z

(Go on to the next page)

3. Janet found animal Q as shown in the diagram below.

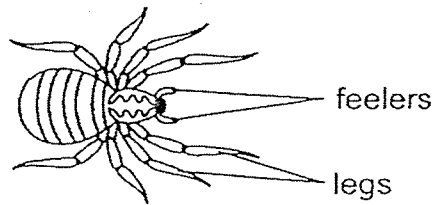

Animal Q

Which of the following characteristics about animal Q tells Janet that it is **not** an insect?

- (1) It has no wings.
- (2) It has eight legs.
- (3) It has a pair of feelers.
- (4) It has more than one body part.

4. Beatrice wants to classify the following animals into two groups, Group A and Group B.



Human

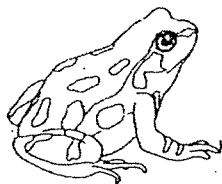

Frog

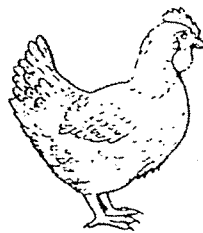

Chicken

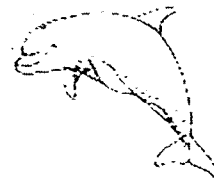

Dolphin

Which of the following is a possible heading for the two groups?

	Group A	Group B
(1)	Have hair	Have scales
(2)	Lay eggs	Give birth to young
(3)	Have two legs	Have four legs
(4)	Live on land only	Live in water only

(Go on to the next page)

5. The diagram below shows the life cycle of living thing P.

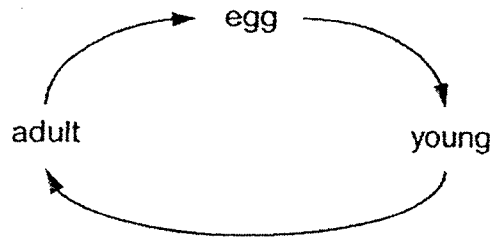

Based only on the life cycle above, which of the following statements is true?

- (1) P lives on land.
- (2) P definitely lays eggs.
- (3) The young of P does not resemble the adult.
- (4) The time taken for P to grow from one stage to another may not be the same.

6. The following pictures show the different stages in the life cycle of a plant.

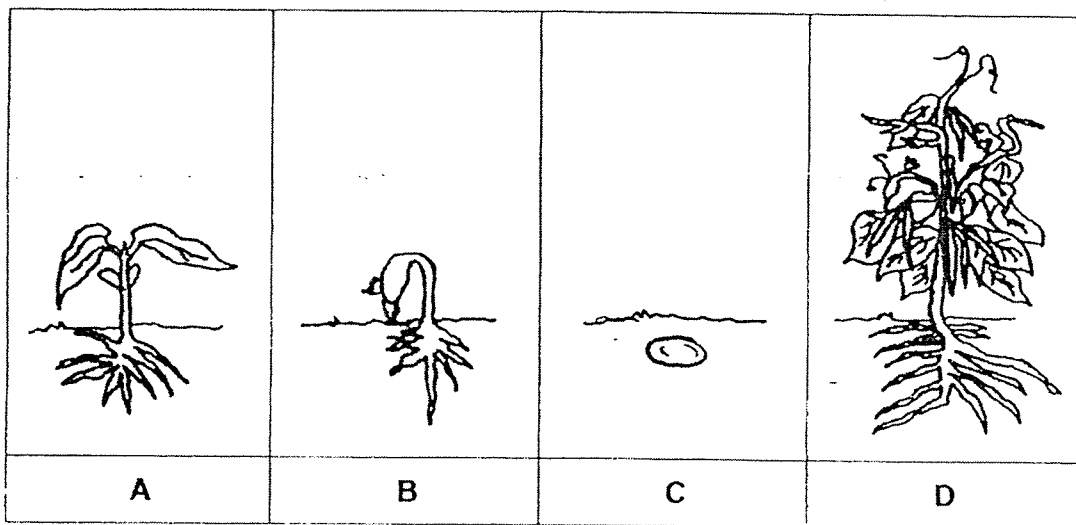

At which stage(s) of the life cycle does the plant make its own food?

- (1) D only
- (2) A and B only
- (3) A and D only
- (4) A, B, C and D

(Go on to the next page)

7. The picture below shows how the leaves of a plant may grow. It was observed that the leaves of most plants grow in a way that do not overlap each other too much.

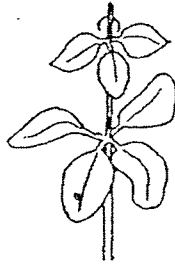

Which of the following best explains the reason for this observation?

- (1) The plant can take in more water.
 - (2) The plant can look more beautiful.
 - (3) The leaves can take in more gases.
 - (4) The leaves can take in more sunlight.
8. There was heavy rain and strong winds on a stormy day. A tree fell onto a house as shown below.



Which of the following best explains why the tree fell?

- (1) The stem cannot hold the tree upright.
- (2) The stem cannot support the weight of the tree.
- (3) The roots cannot absorb water from the ground.
- (4) The roots cannot hold the tree firmly to the ground.

(Go on to the next page)

9. Kelly conducted an experiment with three similar plants, A, B and C. She cut off all the leaves from plant A and only some leaves from plant B. No leaves were cut from plant C.

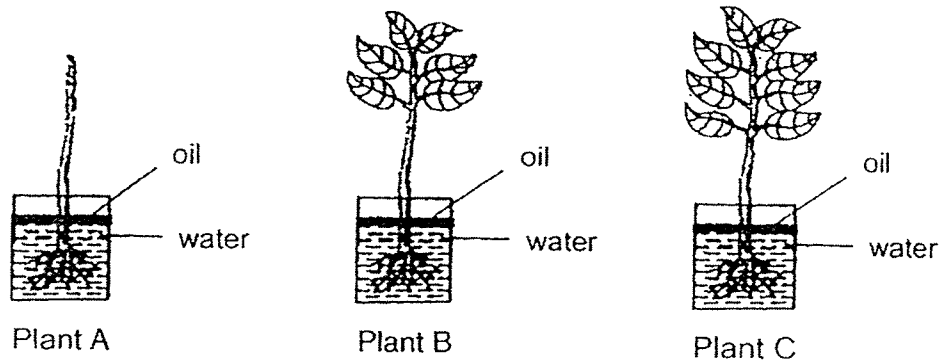

Kelly then placed each plant in a container with 300 ml of water. The plants were placed at the same location. A layer of oil was added to prevent water loss to the surrounding air.

Kelly recorded the amount of water left in each container the next day.

Plant	Amount of water left in the container after one day (ml)
A	250
B	180
C	100

The aim of the experiment is to find out if the _____.

- (1) roots of a plant absorb water
- (2) stem of a plant absorbs water
- (3) type of plant affects the amount of water taken in by the plant
- (4) number of leaves affects the amount of water taken in by the plant

(Go on to the next page)

10. The following objects are grouped according to the materials they are made from.

Group 1	Group 2	Group 3	Group 4
tyre	book	towel	coin
eraser	newspapers	bedsheet	paper clip

In which group should a "balloon" belong to?

- (1) Group 1
 - (2) Group 2
 - (3) Group 3
 - (4) Group 4
11. Four children, Heidi, Ian, Jay and Kelly, visited a playroom at the Science Centre. There are four walls built with materials A, B, C and D, in the playroom.

Material	Allows most light to pass through	Allows some light to pass through	Does not allow light to pass through
A			✓
B	✓		
C		✓	
D	✓		

The children stood behind the walls as shown in the diagram below.

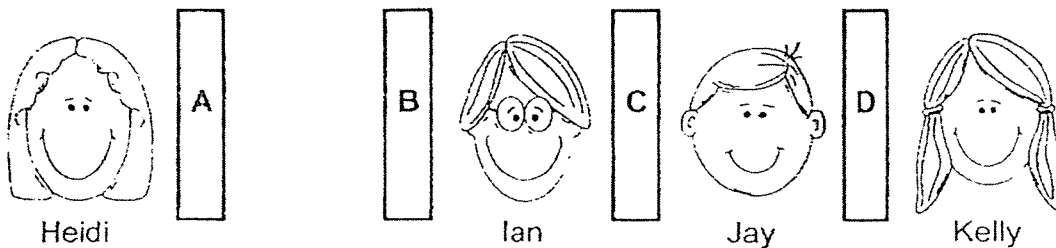

Which of the following statements is true?

- (1) Heidi can see Jay.
- (2) Kelly can see Heidi.
- (3) Jay can see Ian and Kelly.
- (4) Ian can see Heidi and Jay.

(Go on to the next page)

12. Ken wanted to make a swing for his son. He tested out four different materials J, K, L and M to make part T of the swing as shown in the diagram below.

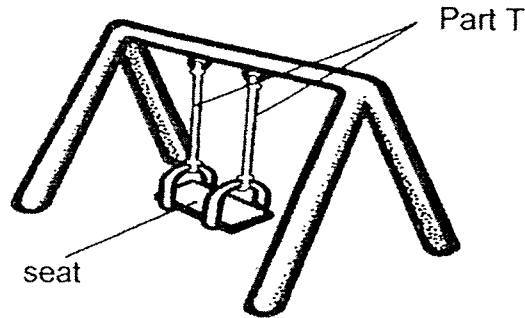

In the experiment, Ken put weights on the seat of the swing and recorded the total mass Part T could hold before it broke in the table below.

Material	Total mass that Part T could hold before breaking (kg)
J	14
K	52
L	35
M	20

Based on the information in the table, which material should Ken use if his son has a weight of 23kg?

- (1) K only
- (2) J or M only
- (3) K or L only
- (4) K, L or M only

(Go on to the next page)

13. Gary tied a string to a bar magnet as shown below.

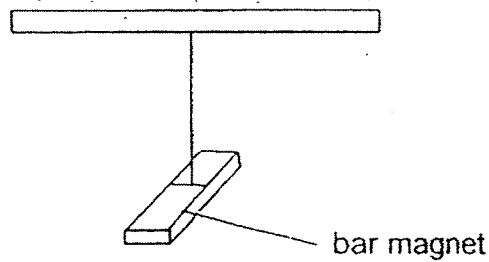

He pushed the magnet gently and it came to rest after some time.

In which direction would the bar magnet point when at rest?

- (1) east-west
 - (2) north-west
 - (3) north-south
 - (4) south-east
14. Aaron found two objects Q and R, in a box. He placed one end of a bar magnet near each object and recorded his observations in the table below.

Object	Observation
Q	Moved towards the bar magnet
R	Did not move

Based on his observation, which of the following correctly shows what objects Q and R could be?

	Object Q	Object R
(1)	Aluminium foil	Plastic spoon
(2)	Plastic spoon	Steel ruler
(3)	Needle	Aluminium foil
(4)	Steel ruler	Needle

(Go on to the next page)

15. Study the arrangement of the three magnets below. They are attracted to each other.

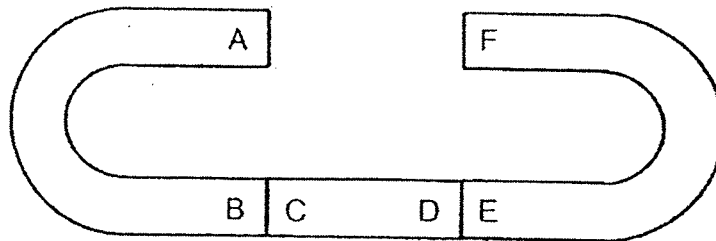

Three students made the following statements based on the arrangement above.

Jane : C will repel E.

Kate : A will attract F

Louis : F will attract D

Which of the statement(s) below is/are correct?

- (1) Jane only
- (2) Kate only
- (3) Jane and Kate only
- (4) Kate and Louis only

END OF SECTION A



AI TONG SCHOOL

2020 END-OF-YEAR EXAMINATION PRIMARY THREE SCIENCE

(BOOKLET B)

29 OCTOBER 2020

Total time for booklets A and B : 1 h

INSTRUCTIONS

Do not turn over this page until you are told to do so.

Follow all instructions carefully.

Answer all questions.

Write your answers in this booklet.

Name : _____ ()

Class : Primary 3 _____

Parent's Signature : _____

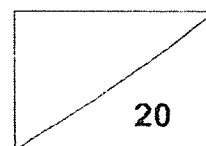

Section B: 20 marks

Read the questions carefully and write your answers in the spaces provided.

16. Study the classification chart below.

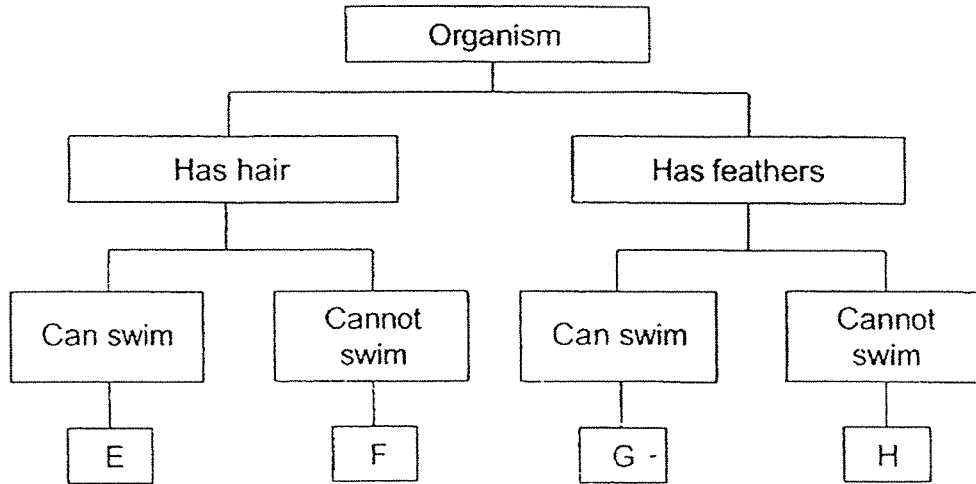

(a) Based on the classification chart, state the characteristics of organism H. [1]

(b) The picture below shows organism A.

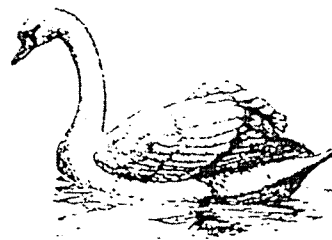

Organism A

Based on the classification chart, write down one difference between organism A and organism E.



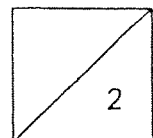

[1]

(Go on to the next page)



17. Joe wanted to find out if the amount of water will affect the amount of mould growing on bread. He added different drops of water to four similar pieces of bread, W, X, Y and Z. He placed all the four pieces of bread in a cupboard for five days:

He recorded his observations after five days in the table below.

Bread	W	X	Y	Z
Number of drops of water	2	4	6	8
How the bread looks after 5 days				

- (a) From the results above, how does the amount of water affect the growth of bread mould? Complete the following sentence by circling the correct answer in the brackets. [1]

The (more / less) the amount of water on the bread, the
(more / less) the mould will grow on the bread.

- (b) Joe wanted to conduct another experiment to find out if warmth is needed for bread mould to grow. Which of the following variable(s) must Joe keep constant in order for the experiment to be a fair test?

Put a tick (✓) in the correct box(es). [1]

Condition	Tick (✓)
Size of bread	
Amount of water	
Temperature of the surrounding where bread is placed	

- (c) Which group of living things does the bread mould belong to? [1]

(Go on to the next page)

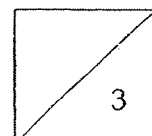

18. The diagrams below show the stages in the life cycle of a beetle.

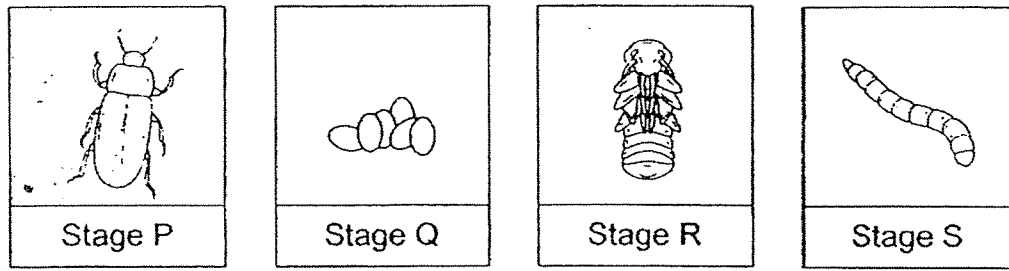

(a) Arrange the stages P, Q, R and S to show the life cycle of the beetle. [1]

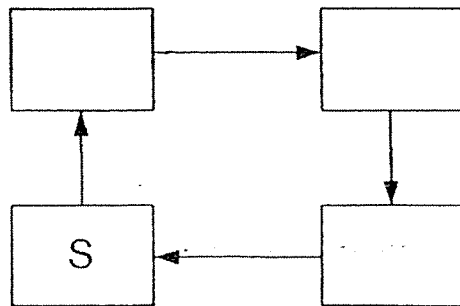

(b) The grasshopper is also an insect, just like the beetle. State one difference between the life cycle of a beetle and the life cycle of a grasshopper. [1]

(Go on to the next page)

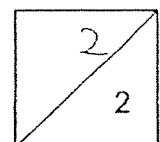

19. In an experiment, Lydia put three similar seeds between two types of soil, dry and moist, in a container as shown below.

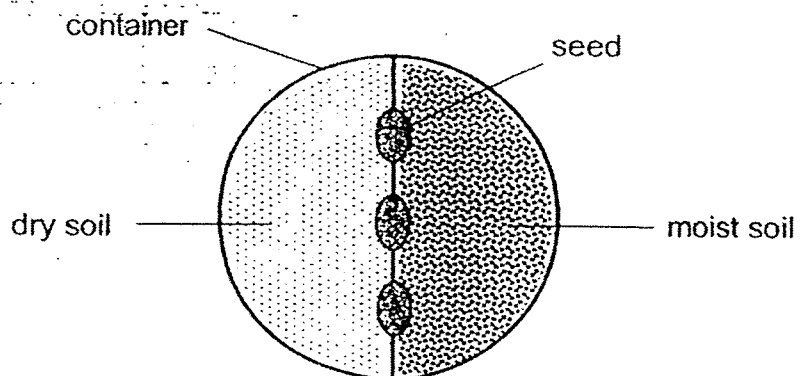

Lydia then placed the container in her classroom. The next day, the seeds germinated. In which direction would the roots of the seeds grow towards? Explain your answer.

[2]

(Go on to the next page)

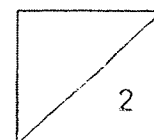

20. Arul observed Plant G growing in his garden.

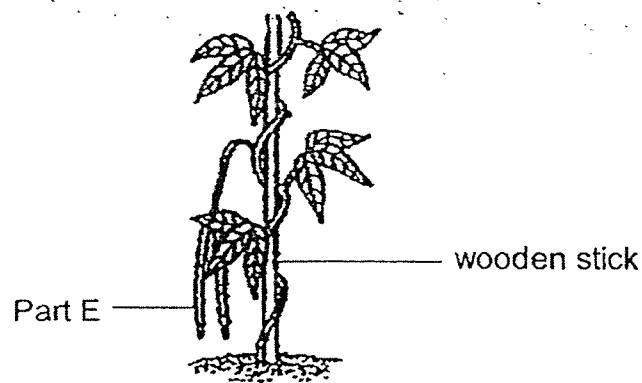

Plant G

- (a) Plant G grows on a wooden stick, which is a support for the plant to grow. What does this show about the stem of Plant G? [1]

- (b) Explain how growing on the wooden stick will help the leaves of Plant G. [1]

- (c) Part E is the fruit of the plant. When Arul opened up the fruit, he saw some seeds inside it. How are the seeds useful to the plant? [1]

(Go on to the next page)

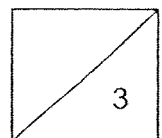

21. Study the flowchart below.

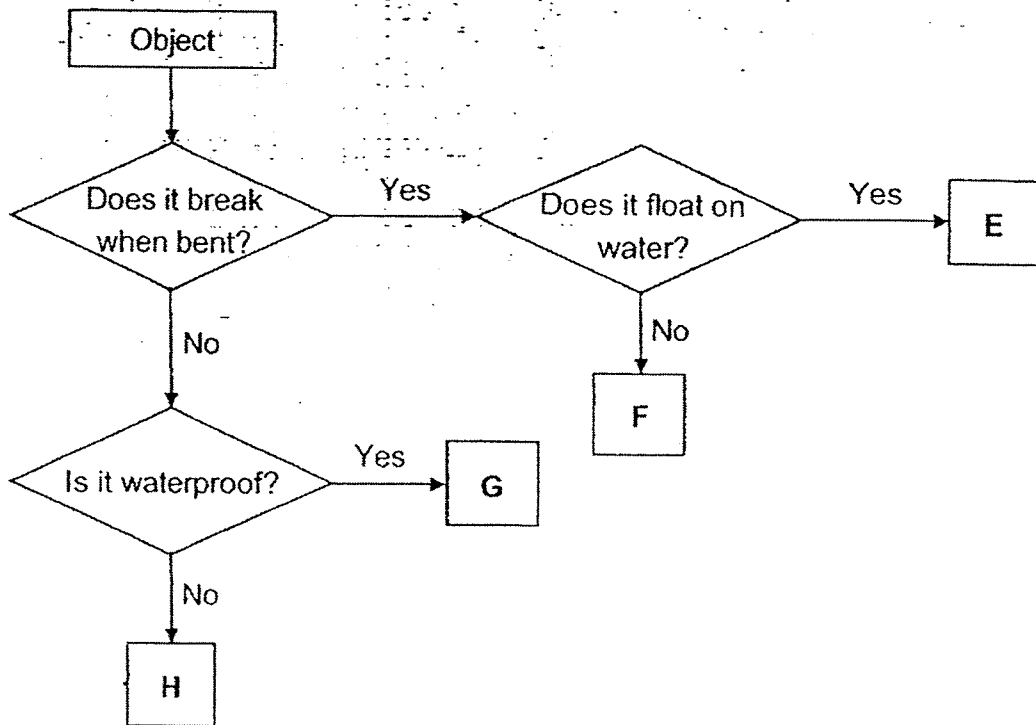

(a) Based on the flowchart, write down one similarity between objects G and H. [1]

(b) Using the information from the flowchart, write the letters E, F, G or H that best describe the objects below. [1]

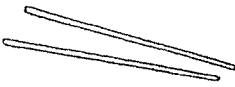
Object	Letter
 plastic bag	
 wooden chopsticks	

(Go on to the next page)

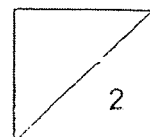

22. Raju set up an experiment to find out how much water three pieces of fabric, A, B and C can absorb. All the fabric are of the same size. He dipped one end of each piece of fabric into a container of blue coloured water as shown below.

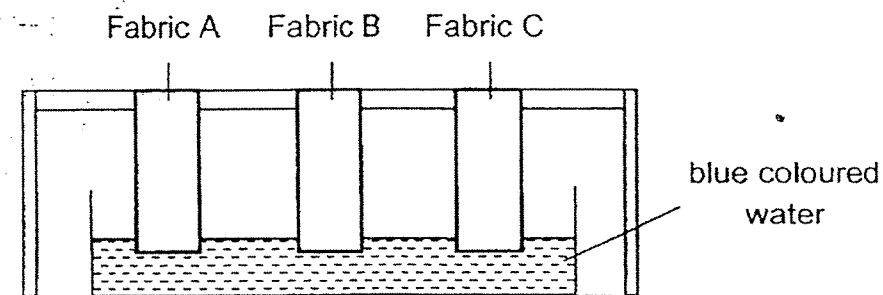

The distance that the blue coloured water travelled up each fabric after five minutes is recorded in the table below.

	Fabric A	Fabric B	Fabric C
Distance that blue coloured water travelled up fabric (cm)	5	18	10

- (a) Arrange the fabrics in order of their absorbency, from the least absorbent to the most absorbent fabric in the boxes provided. [1]

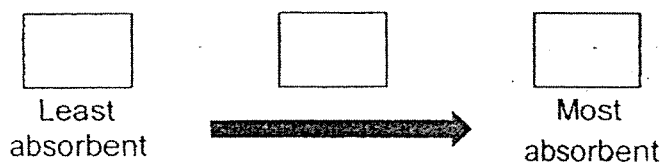

Question 22 continues on the next page.

(Go on to the next page)

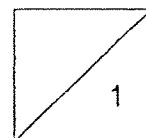

Question 22 continues on this page.

(b) Raju had an umbrella and he cut a piece of fabric T as shown below.

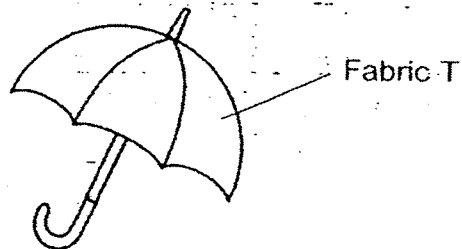

Raju then dipped one end of the fabric T into the container with blue coloured water.

(i) What is the distance that the blue coloured water would most likely to travel up the fabric? [1]

_____ cm

(ii) Explain your answer in (i). [1]

(Go on to the next page)

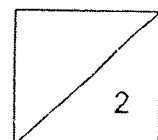

23. Emily labelled four parts, J, K, L and M on a bar magnet, A. She placed the bar magnet into a box of pins and noticed that the pins were attracted to the magnet. She recorded her observation in the bar graph shown below.

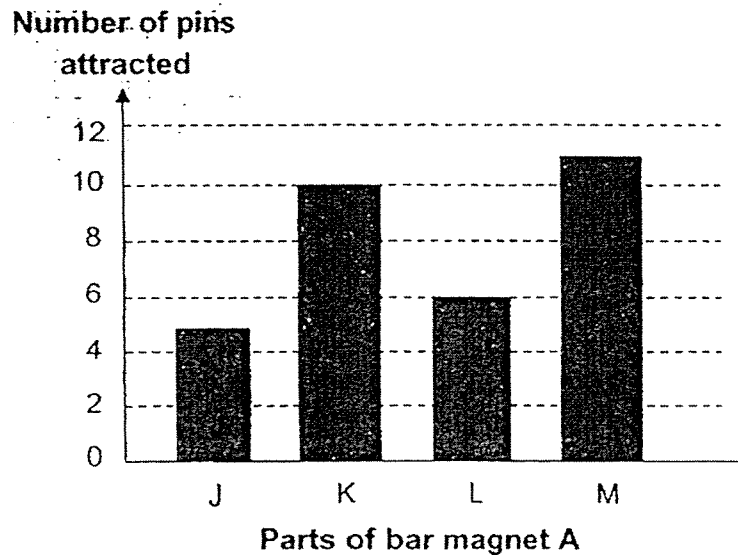

- (a) Based on the information, which two parts represent the poles of the bar magnet? [1]

- (b) Explain your answer in (a). [1]

Question 23 continues on the next page.

(Go on to the next page)

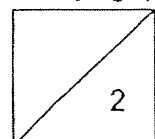

Question 23 continues on this page.

Emily brought one end of object G near the bar magnet A and they attracted each other as shown below. She concluded that object G is also a magnet.

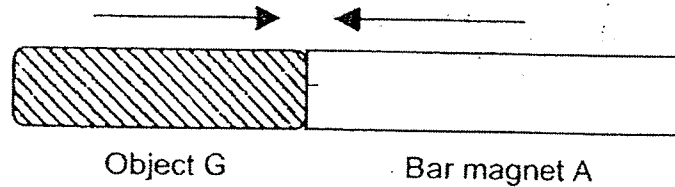

However, her brother, Jacky, said that what Emily had observed could not prove that object G is a magnet.

- (c) Suggest what Emily could do to prove that object G is a magnet. [1]

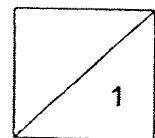

End of Paper

YEAR : 2020
 LEVEL : PRIMARY 3
 SCHOOL : AI TONG SCHOOL
 SUBJECT : SCIENCE
 TERM : END OF YEAR EXAMINATION

Q1	1	Q2	4	Q3	2	Q4	2	Q5	4
Q6	3	Q7	4	Q8	4	Q9	4	Q10	1
Q11	3	Q12	3	Q13	3	Q14	3	Q15	3

Q16	(a)Organism H has feathers and is not able to swim. (b)Organism A has feathers as the outer covering but Organism E has hair as the outer covering
Q17	(a)more more (b) Size of bread, Amount of water (c)The bread mould belongs to fungi
Q18	(a) $R \rightarrow P \rightarrow Q$ (b)The beetle has a four stage life cycle but the grasshopper has a three stage life cycle.
Q19	The roots of the seeds will grow towards the moist soil because it needs to absorb the water in order for the plant to survive.
Q20	(a)This shows that the stem of plant G is weak. (b) Growing on the wooden stick will help the leaves absorb more sunlight to make more food. (c)The seeds are useful to the plants because they help the plants to reproduce.
Q21	(a)Object G and H does not break when bent (b)G, E
Q22	(a)A, C, B (b)(i)0cm (ii)Fabric T will not absorb any water because it is waterproof.

Q23	<p>(a) K and M because K and M attracted the most number of pins. A magnet is the strongest part at its poles.</p> <p>(b) It is K and L because a magnet is always strongest at its poles.</p> <p>(c) Emily could turn Object G to the other side and show that it repelled Bar magnet A.</p>
-----	---